

K 斜齿 - 锥齿齿轮马达

K Helical-Bevel Gearmotor

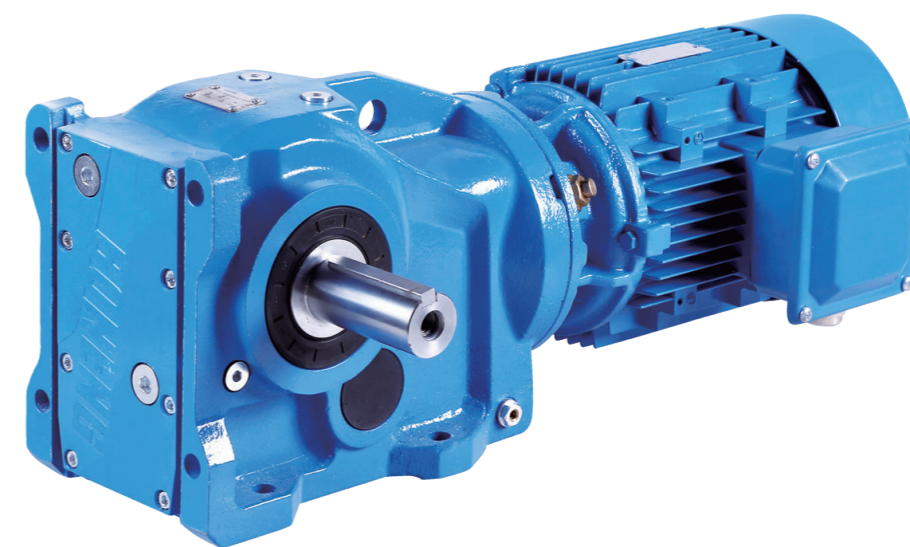

K斜齿-锥齿齿轮
马达

K Helical-Bevel
Gearmotor

Edit date 04/2026
Selection Catalogue: C05.0018

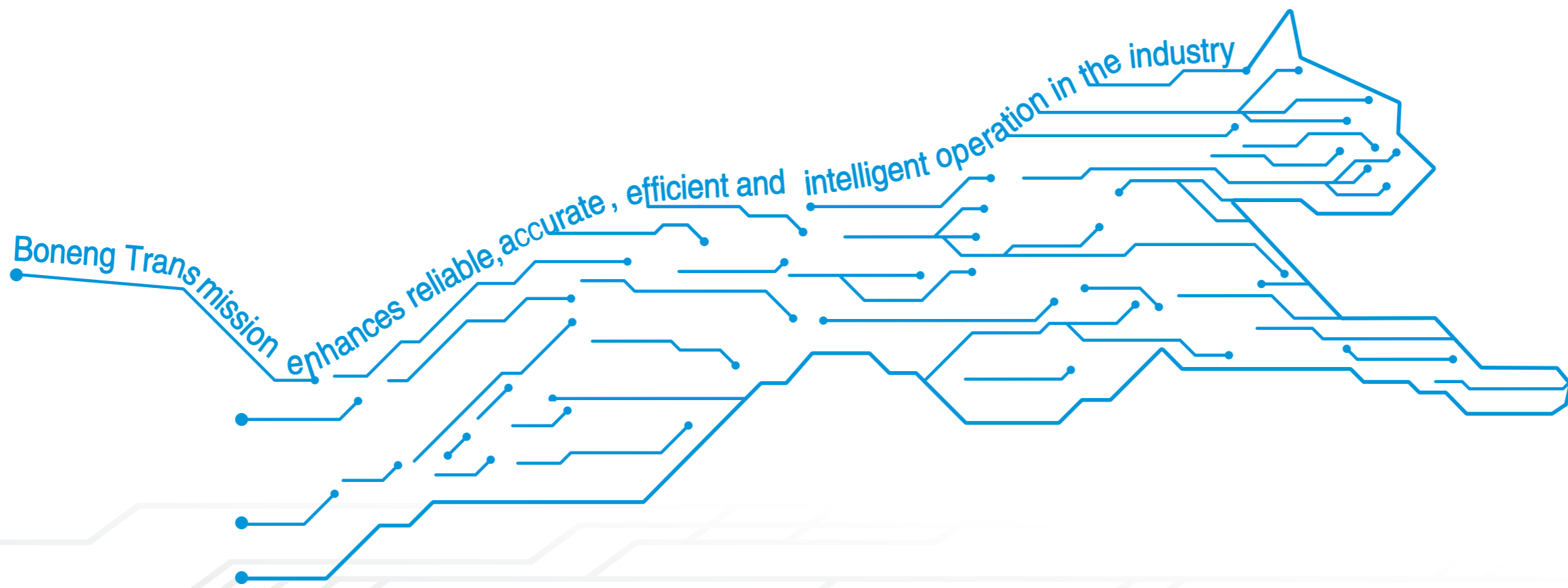

控制器/驱动器/马达/
齿轮马达/齿轮箱

Controller/ Drive/ Motor/
Gearmotor/ Gearbox

K斜齿-锥齿齿轮马达

- ◆ 灵活多变的模块化理念设计的齿轮马达。
- ◆ 直交传动结构，节省安装空间，满足多种传动结构需求。
- ◆ 有限元优化铸造箱体，提高30%的运行稳定性和抗震性能。
- ◆ 高达94%的模块化设计，便于当地组装生产，更加快捷的生产和物流周期。
- ◆ 高可靠性和长设计寿命可有效降低您的使用成本及维护成本。
- ◆ 多种输出及布置形式可满足400多种安装使用方式。

K Helical-Bevel Gearmotor

- ◆ Gearmotor with flexible and modular design.
- ◆ Orthogonal transmission structure saves mounting space and meets the needs of various transmission structures.
- ◆ The FEA design of the casting housing improves the stability of operation and seismic performance by 30%.
- ◆ Up to 94% modular design, international production, faster production and logistics cycles.
- ◆ High reliability and long design life can effectively reduce your use and maintenance costs.
- ◆ A variety of output and assemblies can meet more than 400 mounting cases.

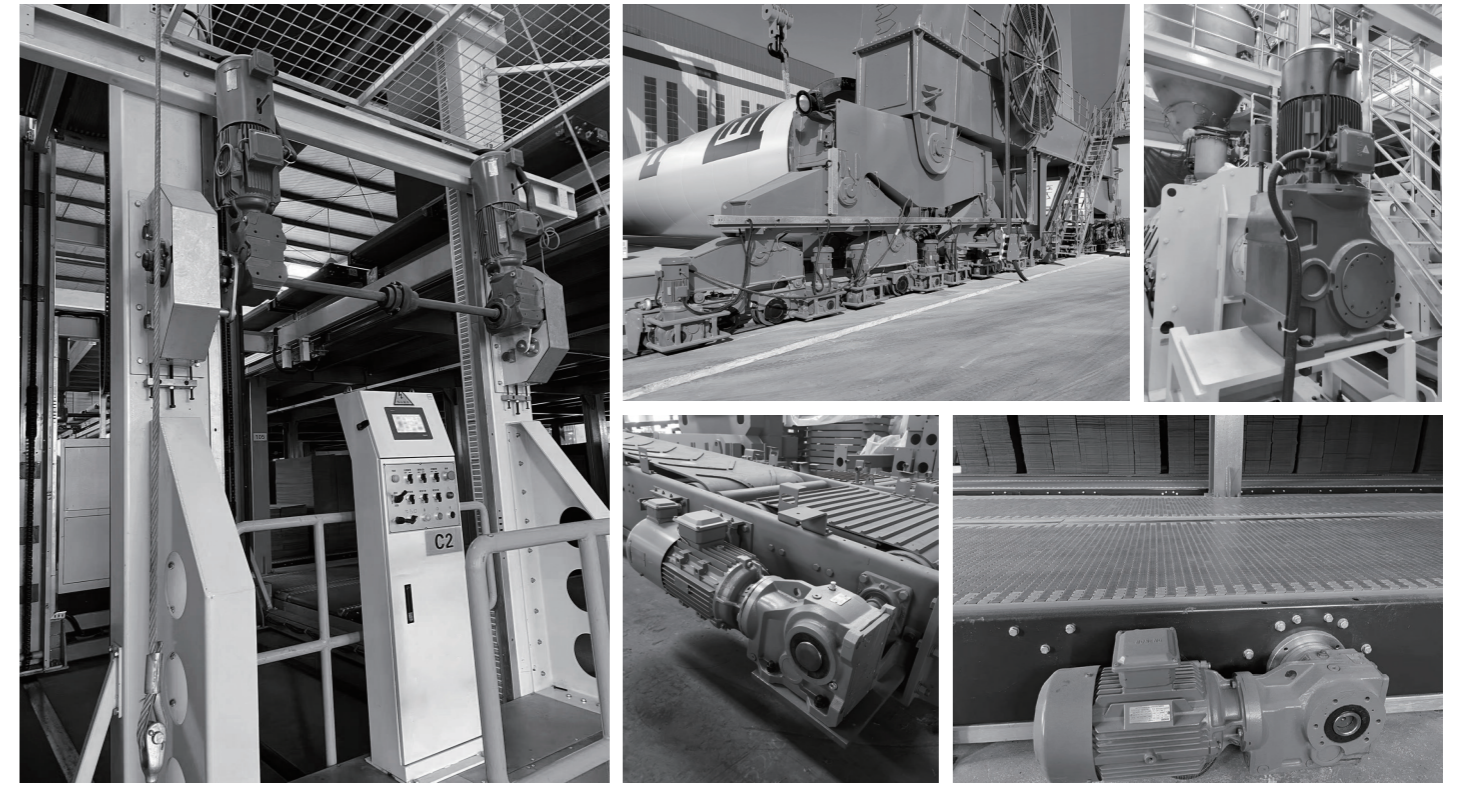

产品广泛应用于港口、起重、电力、采矿、水泥、造纸、化工等各个领域。

博能传动公司总部和各大区域的技术专家以及各区域办事处的应用工程师、售后服务技师竭诚为您提供全面的技术咨询和完美的服务。

Products are widely used in Port, Crane, Power, Mining, Cement, Paper, Chemical and other fields.

Boneng Transmission company headquarters and major regional technical experts and regional offices of the application engineers, after-sales service technicians dedicated to provide you with comprehensive technical advice and perfect service.

目录

Contents

注意事项:

- ◆ 样本中的结构示意图、外形图及其他附图只属范例，无严格比例要求。（未注尺寸单位均为mm）。
- ◆ 所注重量仅为平均值，并不具有约束力。

⚠️ 必须严格遵守以下各项:

- ◆ 为防止意外事故发生，所有旋转部件均按照使用者所在国家和地区的安全规范由购置方加罩保护。
- ◆ 试车之前必须认真阅读使用说明书。
- ◆ 齿轮马达在供货时已处于准运行状态，运行前需加注润滑油。
- ◆ 本样本中注油量只作为参考值，实际注油量应以油镜上的标记为准。
- ◆ 润滑油粘度应按齿轮马达使用工况及使用环境温度选取。
- ◆ 推荐采用知名品牌的润滑油。

Note:

- ◆ The structure scheme, appearance diagram and other attached diagrams in sample are examples, there is no strict proportion requirement.(The unmarked dimension units are mm).
- ◆ The marked weight is average value,it has no constraint force.

⚠️ You must conform to the following instructions:

- ◆ To prevent accidents,all the rotation parts are added with protective covers according to the safety regulations of the nation and region.
- ◆ Before debugging,you should carefully read instruction book.
- ◆ Gearbox is on running-permission status when delivered,you should add lubrication oil before putting it into running.
- ◆ The marked oil quantity in sample is only reference value,actual oil filling quantity should be the same with the mark on oil immersion lens.
- ◆ Lubrication oil viscosity should be selected according to working situation and application environment temperature of gearmotor.
- ◆ You can only apply lubrication oil of internationally famous brand.

01.型号表示方法	01	01.Type Designation	03
02.选型及举例	05	02.Type Selection and Example	07
03.传动能力表	09	03.Transmission Capacity	09
04.允许的径向力	21	04.Permissible Radial Force	21
05.外形尺寸图表	23	05.Dimensions	23
06.输入法兰和输入轴	59	06.Input Flange and Input shaft	59
07.马达防雨罩尺寸	68	07.Motor Rainproof Cover Dimensions	68
08.被驱动轴推荐尺寸	69	08.Recommended Dimensions for Driven Equipment Shaft	69
09.轴端中心孔尺寸	71	09.Shaft End Centre Hole	71
10.平键与键槽的尺寸	72	10.Dimension of Parallel Key and Keyway	72
11.可选附件和指定配置	73	11.Accessories & Specific Configuration	73
12.润滑油	75	12.Oil	75
13.重量表	77	13.Weight	77

1 型号表示方法

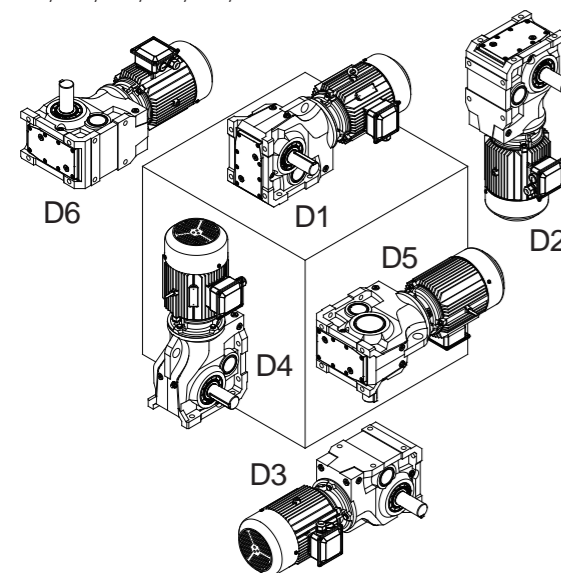

可选附件和指定配置

0=无可选
1=齿轮非常规安装

润滑油代号

0=不加润滑油 (不加油出厂时, 请选此项)
1=矿物润滑油VG220 (环境温度为-20°C~+40°C, K303~K312需加油出厂时, 请选此项)
2=矿物润滑油VG320 (环境温度为-20°C~+40°C, K315~K318需加油出厂时, 请选此项)
5=合成润滑油VG220 (环境温度<0°C,需加油出厂时, 推荐选用此项)

- ◆配IEC马达输入法兰的齿轮箱型号示例:K308HA-C32-D101-AP112
- ◆配NEMA马达输入法兰的齿轮箱型号示例:K308HA-C32-D101-AN145
- ◆配输入轴的齿轮箱型号示例:K308HA-C32-D101-AE3

MP132M4B55AC 3-A 0 N 0 0-0 1 1

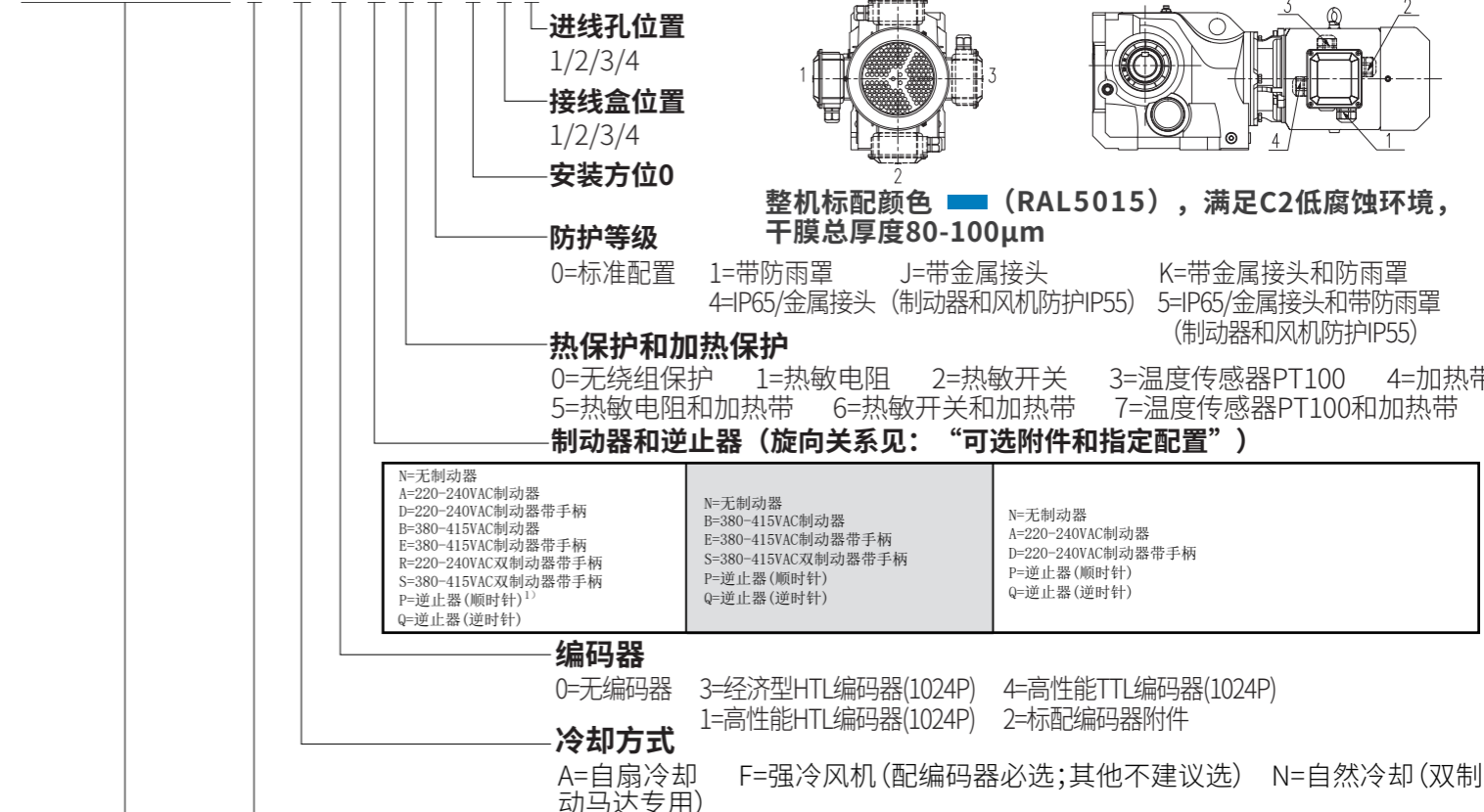

马达接线盒和进线孔位置 (视角:D1方位马达尾部)

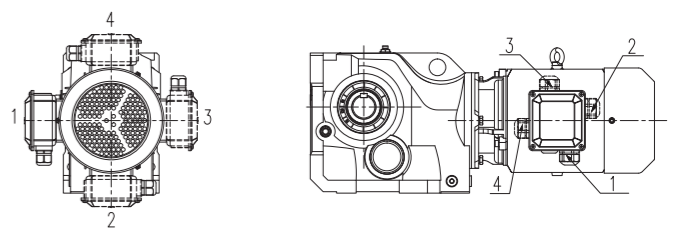

整机标配颜色 (RAL5015), 满足C2低腐蚀环境, 干膜总厚度80-100µm

频率/电压 1=50Hz 220V△/380VY 2=50Hz 230V△/400VY 7=60Hz 440VY 8=60Hz 460VY A=50Hz 240V△/415VY C=60Hz 480VY E=60Hz 220V△/380VY	频率/电压 3=50Hz 380V△/660VY 4=50Hz 400V△/690VY 5=60Hz 440V△ 6=60Hz 460V△ B=50Hz 415V△ D=60Hz 480V△ F=60Hz 380V△	频率/电压 G=60Hz 230VY 8=60Hz 460VY J=60Hz 575VY	频率/电压 H=60Hz 230V△ 6=60Hz 460V△ K=60Hz 575V△
---	---	---	---

三相交流异步马达4极规格

功率 (kW)	MP=IE3 MU=IE4	功率 (kW)	MP=IE3 MU=IE4	功率 (kW)	MA=MG1	功率 (kW)	MA=MG1
0.12	MP063M4A12AL MU063M4A12AL	4	MP112L4B40AC MU132S4B40AC	0.12	MA063M4A12AL	4	MA112L4B40AC
0.18	MP063M4A18AL MU071M4A18AL	5.5	MP132M4B55AC MU132M4B55AC	0.18	MA063M4A18AL	5.5	MA132L4B55AC
0.25	MP071M4A25AL MU071M4A25AL	7.5	MP132L4B75AC MU160M4B75AC	0.25	MA071M4A25AL	7.5	MA132L4B75AC
0.37	MP071M4A37AL MU080M4A37AL	11	MP160M4C11AC MU160L4C11AC	0.37	MA071M4A37AL	11	MA160M4C11AC
0.55	MP080M4A55AL MU080M4A55AL	15	MP160L4C15AC MU180M4C15AC	0.55	MA080M4A55AL	15	MA160L4C15AC
0.75	MP080M4A75AL MU090S4A75AL	18.5	MP180M4C18AC MU180L4C18AC	0.75	MA080M4A75AL	18.5	MA180M4C18AC
1.1	MP090S4B11AL MU090L4B11AL	22	MP180L4C22AC MU200L4C22AC	1.1	MA090M4B11AL	22	MA180L4C22AC
1.5	MP090M4B15AL MU100L4B15AL	30	MP200M4C30AC MU225S4C30AC	1.5	MA090M4B15AL	30	MA200M4C30AC
2.2	MP100M4B22AL MU100L4B22AL	37	MP225M4C37AC MU225M4C37AC	2.2	MA100M4B22AL	37	MA225M4C37AC
3	MP100M4B30AL MU112M4B30AC	45	MP225M4C45AC MU250M4C45AC	3	MA100M4B30AL	45	MA225M4C45AC
/	/	55	MP250M4C55AC MU280S4C55AC	/	/	55	MA250M4C55AC
/	/	75	MP280S4C75AC MU280M4C75AC	/	/	75	MA280S4C75AC
/	/	90	MP280M4C90AC MU280M4C90AC	/	/	90	MA280M4C90AC

1) 逆止器可选电机机座号范围为100~280, 顺逆时针视角为从电机轴伸端向电机风扇罩;
2) 齿轮箱输出轴旋向和逆止器选项的关系详见“可选附件和指定配置”。

1 Type Designation

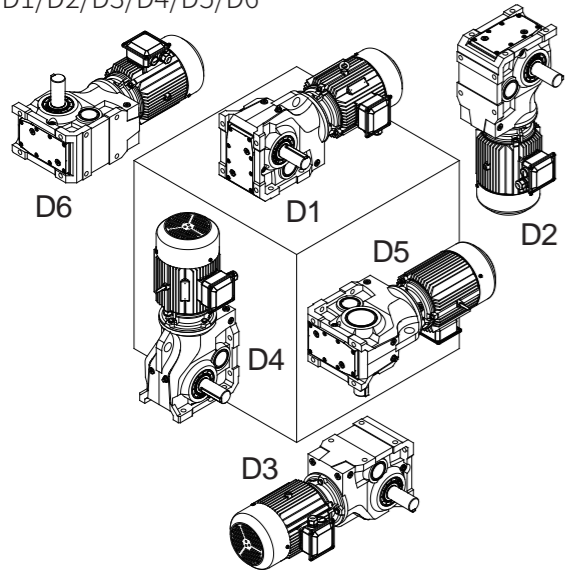
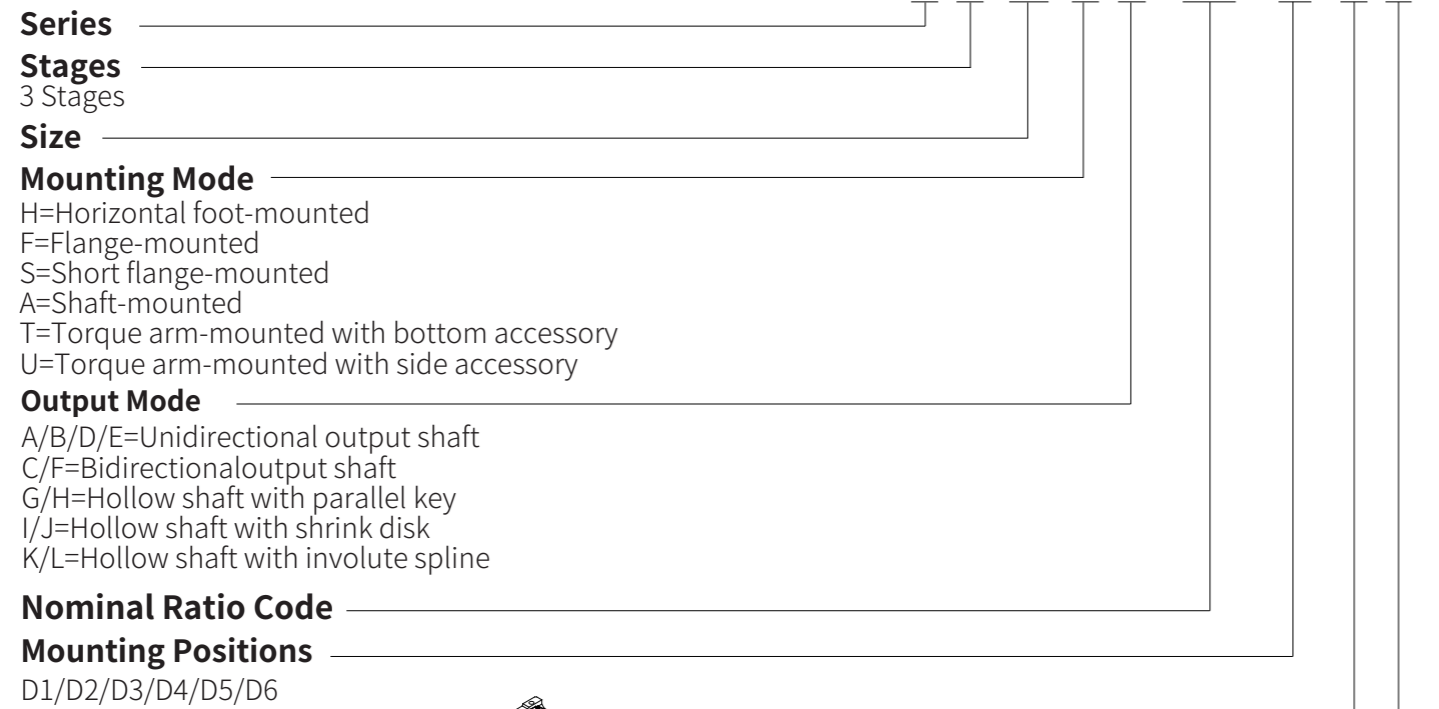

Accessories and Specific Configuration

0=None
 1=Unconventional installation of gear

Oil Code

0=Without oil filling (Please select this option when you do not need lubricating oil);
 1=With mineral oil VG220 (Please select this option when the ambient temperature is -20°C~+40°C, and K303~K312 need lubricating oil);
 2=With mineral oil VG320 (Please select this option when the ambient temperature is -20°C~+40°C, and K315~K318 need lubricating oil);
 5=With synthetic lubricating oil VG220 (It is recommended to select this option when you need lubricating oil and the ambient temperature is below 0°C);

- ◆ Example of gearbox with input flange for IEC motor connection: K308HA-C32-D101-AP112
- ◆ Example of gearbox with input flange for NEMA motor connection: K308HA-C32-D101-AN145
- ◆ Example of gearbox with input shaft: K308HA-C32-D101-AE3

MP132M4B55AC 3 - A 0 N 0 0 - 0 1 1

Cable Entry Position

1/2/3/4

Terminal Box Position

1/2/3/4

Motor Mounting Position 0

Motor protection

0=Standard configuration
 1=With rain cover
 J=With metal joint
 K=With metal joint and rain cover
 4=IP65/with metal joint (brake and forced-fan IP55)
 5=IP65/with metal joint and rain cover

Thermal Protection and Heating Protection

0=Without thermal protection
 1=Thermistor
 2=Thermal switch
 3=PT100 temperature sensor
 4=Heating belt
 5=Thermistor and heating belt and heating protection
 6=Thermal switch and heating belt
 7=PT100 temperature sensor and heating belt

Brakes and Backstop (Relationship of rotational direction can be checked in "Accessories & Specific Configuration".)

N=No brake A=220-240VAC Brake D=220-240VAC Brake with release handle E=380-415VAC Brake F=380-415VAC Brake with release handle R=220-240VAC Double brake with release handle S=380-415VAC Double brake with release handle P=Backstop (CW) Q=Backstop (CCW)	N=No brake B=380-415VAC Brake E=380-415VAC Brake with release handle S=380-415VAC Double brake with release handle P=Backstop (CW) Q=Backstop (CCW)	N=No brake A=220-240VAC Brake D=220-240VAC Brake with release handle P=Backstop (CW) Q=Backstop (CCW)
---	--	---

Encoder

0=No encoder
 1=High-performance HTL encoder(1024P)
 4=High-performance TTL encoder(1024P)
 2=Standard encoder accessories
 3=Economic HTL encoder(1024P)

Cooling Method

A=Self-fan cooling F=Forced-fan cooling N=Natural cooling (for motor with double brake)

Frequency /Vol tage 1=50Hz 220V△/380VY 2=50Hz 230V△/400VY 7=60Hz 440VY 8=60Hz 460VY A=50Hz 240V△/415VY C=60Hz 480VY E=60Hz 220V△/380VY	Frequency /Vol tage 3=50Hz 380V△/660VY 4=50Hz 400V△/690VY 5=60Hz 440V△ 6=60Hz 460V△ B=50Hz 415V△ D=60Hz 480V△ F=60Hz 380V△	Frequency /Vol tage G=60Hz 230VY 8=60Hz 460VY J=60Hz 575VY	Frequency /Vol tage H=60Hz 230V△ 6=60Hz 460V△ K=60Hz 575V△
---	---	---	---

Efficiency three-phase asynchronous motor (4 pole)

Power (kW)	MP=IE3 MU=IE4	Power (kW)	MP=IE3 MU=IE4	Power (kW)	MA=MG1	Power (kW)	MA=MG1
0.12	MP063M4A12AL MU063M4A12AL	4	MP112L4B40AC MU132S4B40AC	0.12	MA063M4A12AL	4	MA112L4B40AC
0.18	MP063M4A18AL MU071M4A18AL	5.5	MP132M4B55AC MU132M4B55AC	0.18	MA063M4A18AL	5.5	MA132L4B55AC
0.25	MP071M4A25AL MU071M4A25AL	7.5	MP132L4B75AC MU160M4B75AC	0.25	MA071M4A25AL	7.5	MA132L4B75AC
0.37	MP071M4A37AL MU080M4A37AL	11	MP160M4C11AC MU160L4C11AC	0.37	MA071M4A37AL	11	MA160M4C11AC
0.55	MP080M4A55AL MU080M4A55AL	15	MP160L4C15AC MU180M4C15AC	0.55	MA080M4A55AL	15	MA160L4C15AC
0.75	MP080M4A75AL MU090S4A75AL	18.5	MP180M4C18AC MU180L4C18AC	0.75	MA080M4A75AL	18.5	MA180M4C18AC
1.1	MP090S4B11AL MU090L4B11AL	22	MP180L4C22AC MU200L4C22AC	1.1	MA090M4B11AL	22	MA180L4C22AC
1.5	MP090M4B15AL MU100L4B15AL	30	MP200M4C30AC MU225S4C30AC	1.5	MA090M4B15AL	30	MA200M4C30AC
2.2	MP100M4B22AL MU100L4B22AL	37	MP225M4C37AC MU225M4C37AC	2.2	MA100M4B22AL	37	MA225M4C37AC
3	MP100M4B30AL MU112M4B30AC	45	MP225M4C45AC MU250M4C45AC	3	MA100M4B30AL	45	MA225M4C45AC
/	/	55	MP250M4C55AC MU280S4C55AC	/	/	55	MA250M4C55AC
/	/	75	MP280S4C75AC MU280M4C75AC	/	/	75	MA280S4C75AC
/	/	90	MP280M4C90AC MU280M4C90AC	/	/	90	MA280M4C90AC

1) Range of motor flame with backstop is 100~280.

View of CW (clockwise) or CCW (counter-clockwise) rotation is from motor shaft-head to fan cover.

2) Relationship of output shaft rotational direction and motor backstop selection can be checked in "Accessories & Specific Configuration".

2 选型及举例

序号	说明	代号	单位	参数																			
1	确定马达的功率	P ₁	kW	按设备需求确认马达功率																			
2	由马达极数、频率、电压确认马达额定转速	n _{1N}	r/min	≤3000rpm 更高转速请咨询																			
3	齿轮箱的输出转速	n _{2N}	r/min	i=n _{1N} /n _{2N}																			
4	输出扭矩	T	N.m	T=P ₁ •9550/n _{2N} , 需要校核输出扭矩是否满足负载设备需求																			
5	选择齿轮箱的服务系数	f ₁	/	<table border="1"> <thead> <tr> <th rowspan="2">负荷性质</th> <th colspan="3">每天使用时间 (小时)</th> </tr> <tr> <th>≤2</th> <th>2~10</th> <th>10~24</th> </tr> </thead> <tbody> <tr> <td>均匀负载</td> <td>1.00</td> <td>1.00</td> <td>1.25</td> </tr> <tr> <td>一般冲击</td> <td>1.00</td> <td>1.25</td> <td>1.50</td> </tr> <tr> <td>强烈冲击</td> <td>1.25</td> <td>1.50</td> <td>1.75</td> </tr> </tbody> </table>	负荷性质	每天使用时间 (小时)			≤2	2~10	10~24	均匀负载	1.00	1.00	1.25	一般冲击	1.00	1.25	1.50	强烈冲击	1.25	1.50	1.75
				负荷性质		每天使用时间 (小时)																	
					≤2	2~10	10~24																
				均匀负载	1.00	1.00	1.25																
一般冲击	1.00	1.25	1.50																				
强烈冲击	1.25	1.50	1.75																				
6	确定齿轮箱所需的最小扭矩	T _{2N}	N.m	T _{2N} ≥T•f ₁																			
7	根据输出转速和齿轮箱所需的最小扭矩选定齿轮箱的机座号	/	/	查传动能力表和外形尺寸图																			
8	选择齿轮箱的安装形式、输出形式、安装方位、附件、润滑油以及马达附件	/	/	查型号表示方法、安装方位及外形尺寸图, 并确认马达附件参数: 制动器、编码器、冷却方式、热保护和加热保护、防护等级(标准IP55)、绝缘等级(F级标准)、接线盒位置和进线孔位置																			
9	确定型号	/	/	查型号表示方法																			
10	根据齿轮级数, 确定齿轮箱传动效率	η	/	K3.. 三级: 94%, K4.. 四级: 92% K5.. 五级: 90%, K6.. 六级: 88%																			
11	准确的输出扭矩和输出转速校核	T ₂ 、n ₂	N.m、r/min	T ₂ =9550•P ₁ •i _{ex} •η/n _{1N} 和 n ₂ =n _{1N} /i _{ex} 查传动能力表, 确定精确减速比i _{ex}																			
12	径向力校核	F _{r1} /F _{r2}	N	查输入轴/输出轴径向力表																			
13	标准环境	/	/	海拔1000m以下, 环境温度-20℃~40℃, 无防腐要求																			
14	其他环境选型要求需要注意事项	/	/	高海拔(>1000m): 马达降额使用系数参照马达选型手册。 高温(>40℃): 马达降额使用系数参照马达选型手册。																			
15	产品特殊要求在订单中备注	/	/	1、油漆RAL色标号的颜色要求: 1)、面漆颜色银白色RAL9006; 2)、底漆标配颜色氧化铁红RAL3009供货; 2、油漆漆膜厚度要求: 1)、C3中腐蚀环境, 干膜总厚度150-180um; 2)、C5-M高腐蚀环境, 干膜总厚度300-360um; 3、低温(-40℃~-20℃), 高速轴油封更换为丁腈橡胶油封; 4、马达H级绝缘等级;																			
16	其他特殊要求需非标设计	/	/																				

序号	已知条件	选型举例						
1	马达功率P ₁ =11kW	P ₁ =11kW						
2	50HZ, 380V, 4极电机	n _{1N} =1450r/min						
3	设备所需转速n ₂ =13r/min	查传动能力表, 取公称输出转速n _{2N} =12.9r/min, 公称减速比i _N =112, 公称减速比代号D11						
4		T=P ₁ •9550/n _{2N} =11x9550/12.9=8143N.m, 满足负载所需扭矩。						
5	负荷性质: 一般冲击, 工作16h/天	f ₁ =1.5						
6	/	T _{2N} ≥T•f ₁ =8143x1.5=12215N.m,						
7	/	查传动能力表, 初定减速机型号K312, T _{2N} =14500N.m>12215N.m; 查K312外形尺寸图, 可直联。						
8	齿轮箱: 法兰安装, 单向实心输出A向, D1安装, 无附件, 出厂不加注润滑油; 马达: 配380VAC制动器(带手柄)、无编码器、无热保护和特殊防护要求接线盒1号位, 进线孔1号位。	<table border="0"> <tr> <td>安装形式代号: F</td> <td rowspan="5">自扇冷却代号: A 配380VAC制动器(带手柄)代号: E 马达接线盒位置代号: 1 马达进线孔位置代号: 1</td> </tr> <tr> <td>输出形式代号: A</td> </tr> <tr> <td>安装方位代号: D1</td> </tr> <tr> <td>无附件代号: 0</td> </tr> <tr> <td>不加润滑油代号: 0</td> </tr> </table>	安装形式代号: F	自扇冷却代号: A 配380VAC制动器(带手柄)代号: E 马达接线盒位置代号: 1 马达进线孔位置代号: 1	输出形式代号: A	安装方位代号: D1	无附件代号: 0	不加润滑油代号: 0
安装形式代号: F	自扇冷却代号: A 配380VAC制动器(带手柄)代号: E 马达接线盒位置代号: 1 马达进线孔位置代号: 1							
输出形式代号: A								
安装方位代号: D1								
无附件代号: 0								
不加润滑油代号: 0								
9	/	查型号表示方法, 选择K312FA-D11-D100-MH160S4C11AC3-A0E00-011						
10	η	0.94						
11	设备所需转速n ₂ =13r/min	i _{ex} =109.1, T ₂ =9550•P ₁ •i _{ex} •η/n _{1N} =9550x11x109.1x0.94/1450=7430N.m, n ₂ =n _{1N} /i _{ex} =1450/109.1=13.3r/min, 综上, 满足设备所需输出扭矩及输出转速。						
12	输出轴径向力45000N	查输入轴/输出轴径向力表, 许用径向力71280N, 满足要求。						
13	标准环境	/						
14	无其他要求	/						
15	无防腐要求	/						
16	无特殊要求	/						

2 Type Selection & Example

Step	Description	Symbol	Unit	Parameters
1	Confirm motor power	P ₁	kW	Confirm motor power according to equipment requirement
2	Confirm nominal motor speed, frequency and voltage.	n _{1N}	r/min	≤3000rpm Consult us if higher speed required.
3	Output speed of Gearbox	n _{2N}	r/min	$i=n_{1N}/n_{2N}$
4	Output torque	T	N.m	$T=P_1 \cdot 9550/n_{2N}$, It is necessary to check whether output torque can meet the requirement of driven machine.
5	Select gearbox service factor	f ₁	/	Load property
				Uniform
				Moderate
				Heavy
6	Confirm minimum torque of gearbox	T _{2N}	N.m	$T_{2N} \geq T \cdot f_1$
7	Determine gearbox size according to output speed and minimum torque of gearbox	/	/	Check transmission capacity and dimensions.
8	Select mounting mode, output mode, accessories, lubricant oil and motor accessories	/	/	Check type designation, mounting position and dimensions, confirm motor accessory parameters (brake, protection, protection level (standard IP55), insulation level (standard F), cable entry position and terminal box position)
9	Determine type	/	/	Check type designation
10	Confirm gearbox transmission efficiency according to gear stages.	η	/	K3.. 3-stage:94%, K4.. 4-stage:92% K5.. 5-stage:90%, K6.. 6-stage:88%
11	Calculate exact output torque and output speed	T ₂ , n ₂	N.m r/min	$T_2=9550 \cdot P_1 \cdot i_{ex} \cdot \eta / n_{1N}$, $n_2=n_{1N}/i_{ex}$ Check transmission capacity table to get exact ratio i_{ex}
12	Proofread radial force	Fr ₁ / Fr ₂	N	Check radial force table of input/output shaft
13	Standard environment	/	/	under 1000m altitude, ambient temperature -20°C~40°C, no anti-corrosion requirement
14	Caution for selection requirement of extra environment	/	/	High altitude (>1000m): Check motor selection catalogue for motor derating service factor. High temperature (>40°C): Check motor selection catalogue for motor derating service factor
15	Please comment in the order if special requirement is needed.	/	/	1. RAL colour number requirement of Painting: 1) Topcoat is silver RAL9006; 2) Undercoat is provided with standard iron oxide red RAL3009; 2. Film thickness requirement of painting: 1) C3 medium-corrosion environment, total thickness of dry film 150~180 μm; 2) C5-M high-corrosion environment, total thickness of dry film 300~360 μm; 3. With low temperature (-40°C~-20°C), oil seals of high-speed shaft should be replaced by NBR oil seals; 4. Motor insulation level H.
16	Non-standard designation is necessary for extra special requirement	/	/	

Step	Known Conditions	Selection Example
1	Motor power P ₁ =11kW	P ₁ =11kW
2	50Hz, 380V, 4-pole motor	n _{1N} =1450r/min
3	Required output speed n ₂ =13r/min	Check transmission capacity table, select nominal output speed n _{2N} =12.9r/min, nominal ratio i _N =112, nominal ratio code D11
4		$T=P_1 \cdot 9550/n_{2N}=11 \times 9550/12.9=8143N.m$, can be satisfied with the required torque.
5	Load property: Moderate, Operation period 16h perday	f ₁ =1.5
6	/	$T_{2N} \geq T \cdot f_1=8143 \times 1.5=12215N.m$,
7	/	Check transmission capacity table to preliminarily select K312 as gearbox type, T _{2N} =14500N.m>12215N.m; Check K312 dimension which can be directly-connected.
8	Gearbox: Flange-mounted, unidirectional solid shaft output A, mounting position D1, without accessory, without adding lubricant oil before delivery; Motor: 380VAC brake with handle release is required, without encoder, without thermal protection and heating protection, cable entry position 1 and terminal box position 1.	Mounting mode code: F Output mode code: A Mounting position code: D1 Code for no accessory: 0 Code for no lubricant oil: 0
9	/	Check type designation and select K312FA-D11-D100-MH160S4C11AC3-A0E00-011
10	η	0.94
11	Required output speed n ₂ =13r/min	$i_{ex}=109.1$, $T_2=9550 \cdot P_1 \cdot i_{ex} \cdot \eta / n_{1N}=9550 \times 11 \times 109.1 \times 0.94/1450=7430N.m$, $n_2=n_{1N}/i_{ex}=1450/109.1=13.3r/min$, According to the above, output torque and output speed are satisfied.
12	Radial force of output shaft 45000N	Check radial force table of input/output shaft, allowable radial force 71280N, which is satisfied with the requirement.
13	Standard environment	/
14	Without extra requirement	/
15	Without anti-corrosion requirement	/
16	Without special requirement	/

3 传动能力表

3.1 K系列传动能力表
(n_{1N}=1450 r/min, i_N=4~180)

3 Transmission Capacity

3.1 K Transmission Capacity
(n_{1N}=1450 r/min, i_N=4~180)

公称输入转速	公称输出转速	公称减速比代号	公称减速比	额定输出扭矩	精确减速比	额定输入功率	额定输出扭矩	精确减速比	额定输入功率	额定输出扭矩	精确减速比	额定输入功率	额定输出扭矩	精确减速比	额定输入功率	额定输出扭矩	精确减速比	额定输入功率
Nominal Input Speed	Nominal Output Speed	Nominal Ratio Code	Nominal Ratio	Rated Output Torque	Exact Ratio	Rated Input Power	Rated Output Torque	Exact Ratio	Rated Input Power	Rated Output Torque	Exact Ratio	Rated Input Power	Rated Output Torque	Exact Ratio	Rated Input Power	Rated Output Torque	Exact Ratio	Rated Input Power
n _{1N} (r/min)	n _{2N} (r/min)	Code	i _N	T _{2N} (N.m)	i _{ex}	P _{1N} (kW)	T _{2N} (N.m)	i _{ex}	P _{1N} (kW)	T _{2N} (N.m)	i _{ex}	P _{1N} (kW)	T _{2N} (N.m)	i _{ex}	P _{1N} (kW)	T _{2N} (N.m)	i _{ex}	P _{1N} (kW)
				K303			K304			K305			K306			K307		
1450	363	B40	4	150	3.95	5.8	200	4.13	7.4	360	4.08	13.4	680	4.20	24.6			
	322	B45	4.5	150	4.46	5.1	230	4.63	7.5	360	4.58	11.9	680	4.82	21.4			
	290	B50	5	150	5.08	4.48	250	5.23	7.3	360	5.18	10.6	700	5.14	20.7			
	259	B56	5.6	160	5.74	4.23	260	5.81	6.8	380	5.75	10.0	730	5.59	19.8			
	230	B63	6.3	180	6.42	4.25	280	6.19	6.9	400	6.56	9.3	750	6.02	18.9			
	204	B71	7.1	180	7.24	3.77	280	6.95	6.1	420	7.41	8.6	750	6.90	16.5	1300	6.86	28.8
	181	B80	8	180	8.25	3.31	300	7.85	5.8	420	8.23	7.7	750	8.00	14.2	1300	7.81	25.3
	161	B90	9	180	9.33	2.93	310	8.71	5.4	430	9.43	6.9	750	9.17	12.4	1300	8.66	22.8
	145	C10	10	180	10.6	2.59	340	9.98	5.2	450	10.4	6.6	750	9.78	11.6	1300	9.93	19.9
	129	C11	11.2	180	11.4	2.40	360	11.0	4.98	460	10.7	6.5	750	11.4	10.0	1300	11.2	17.7
	116	C13	12.5	180	12.7	2.16	380	12.4	4.66	500	12.0	6.3	750	13.0	8.7	1380	12.0	17.4
	104	C14	14	200	14.3	2.13	400	13.5	4.48	550	13.6	6.1	850	13.9	9.3	1550	13.7	17.2
	90.6	C16	16	200	16.3	1.87	420	15.2	4.19	600	15.1	6.0	850	15.7	8.2	1650	15.2	16.5
	80.6	C18	18	210	18.4	1.73	420	17.2	3.71	620	17.3	5.4	850	18.0	7.2	1650	17.4	14.4
	72.5	C20	20	220	20.8	1.60	450	19.1	3.58	650	19.0	5.2	850	19.2	6.7	1650	19.6	12.8
	64.7	C22	22.4	225	22.4	1.52	450	21.8	3.13	680	21.4	4.82	950	22.7	6.3	1650	22.0	11.4
	58.0	C25	25	230	25.6	1.36	450	24.0	2.85	680	22.9	4.51	950	26.0	5.5	1750	25.1	10.6
	51.8	C28	28	230	27.6	1.26	450	27.1	2.53	680	29.5	3.50	950	27.8	5.2	1750	27.8	9.6
	46.0	C32	31.5	230	32.2	1.09	450	31.5	2.17	680	33.1	3.12	950	31.2	4.62	1750	31.0	8.6
	40.8	C36	35.5	230	36.3	0.96	450	37.2	1.83	680	37.4	2.76	950	35.8	4.03	1750	35.3	7.5
	36.3	C40	40	230	41.3	0.85	450	41.8	1.63	680	41.5	2.49	950	38.2	3.78	1750	39.2	6.8
	32.2	C45	45	230	46.7	0.75	450	47.2	1.45	680	47.5	2.17	950	45.5	3.17	1750	44.9	5.9
	29.0	C50	50	230	52.9	0.66	450	52.4	1.30	680	52.3	1.98	950	50.7	2.85	1750	50.5	5.3
	25.9	C56	56	230	57.0	0.61	450	60.1	1.14	680	58.9	1.75	950	55.7	2.59	1750	56.5	4.71
	23.0	C63	63	230	66.7	0.52	450	66.0	1.04	630	62.9	1.52	950	63.3	2.28	1750	62.9	4.23
	20.4	C71	71	230	75.6	0.46	450	74.4	0.92	520	73.2	1.08	950	69.1	2.09	1750	68.9	3.86
	18.1	C80	80	230	83.3	0.42	450	79.5	0.86	520	82.3	0.96	950	78.7	1.83	1750	74.9	3.55
	16.1	C90	90	230	91.1	0.38	450	92.4	0.74	520	89.9	0.88	900	83.6	1.63	1750	84.2	3.15
	14.5	D10	100	230	99.6	0.35	450	104.0	0.66	520	98.6	0.80	850	96.7	1.33	1750	92.3	2.88
	12.9	D11	112				450	113.6	0.60	520	107.1	0.74	850	115.0	1.12	1750	108.3	2.45
	11.6	D13	125				450	124.6	0.55				850	122.3	1.05	1700	120.4	2.14
	10.4	D14	140													1650	132.5	1.89
	9.06	D16	160													1600	149.3	1.63
	8.06	D18	180													1600	175.7	1.38

额定输出扭矩	精确减速比	额定输入功率	额定输出扭矩	精确减速比	额定输入功率	额定输出扭矩	精确减速比	额定输入功率	额定输出扭矩	精确减速比	额定输入功率	额定输出扭矩	精确减速比	额定输入功率	额定输出扭矩	精确减速比	额定输入功率	额定输出扭矩	精确减速比	额定输入功率	
Rated Output Torque	Exact Ratio	Rated Input Power	Rated Output Torque	Exact Ratio	Rated Input Power	Rated Output Torque	Exact Ratio	Rated Input Power	Rated Output Torque	Exact Ratio	Rated Input Power	Rated Output Torque	Exact Ratio	Rated Input Power	Rated Output Torque	Exact Ratio	Rated Input Power	Rated Output Torque	Exact Ratio	Rated Input Power	
T _{2N} (N.m)	i _{ex}	P _{1N} (kW)	T _{2N} (N.m)	i _{ex}	P _{1N} (kW)	T _{2N} (N.m)	i _{ex}	P _{1N} (kW)	T _{2N} (N.m)	i _{ex}	P _{1N} (kW)	T _{2N} (N.m)	i _{ex}	P _{1N} (kW)	T _{2N} (N.m)	i _{ex}	P _{1N} (kW)	T _{2N} (N.m)	i _{ex}	P _{1N} (kW)	
K308		K309		K310		K312		K315		K316		K318									
1800	7.07	38.6	3500	7.24	73				9500	7.14	202										
1800	8.04	34.0	3500	7.93	67	6000	8.14	112	9500	8.11	178										
1800	9.33	29.3	3800	9.37	62	6000	9.11	100	9500	9.45	153										
1800	10.2	26.9	4000	10.5	58	6000	10.7	85	9500	10.5	137	20000	10.1	299	36000	9.97	548	47000	10.1	704	
2100	11.4	27.9	4000	11.2	54	6500	11.7	85	10500	11.7	136	20000	11.5	264	38000	11.2	517	47000	11.4	624	
2350	12.5	28.5	4500	12.8	53	7500	12.5	91	12000	12.6	145	20000	13.4	226	38000	12.4	465	47000	13.2	541	
2350	14.0	25.5	5000	14.3	53	7900	14.0	86	13100	14.3	140	20000	14.9	204	38000	14.0	413	47000	15.1	474	
2600	15.9	24.8	5000	16.2	46.9	8300	16.5	76	14500	16.6	133	20000	16.6	183	38000	16.1	358	47000	16.1	442	
2600	18.5	21.4	5000	18.1	41.9	8300	17.9	70	14500	18.5	119	20000	18.4	165	38000	17.8	325	47000	17.4	409	
2600	20.1	19.6	5000	19.4	39.2	8300	20.9	60	14500	20.6	107	20000	19.9	152	38000	19.7	293	50000	20.2	376	
2850	22.6	19.1	5000	22.2	34.3	8300	23.2	54	14500	22.7	97	20000	22.9	133	38000	21.7	265	53000	22.5	357	
3000	24.8	18.4	5000	24.6	30.8	8300	24.6	51	14500	24.6	89	20000	24.1	126	38000	24.3	237	53000	24.1	334	
3000	28.6	15.9	5000	27.9	27.2	8300	27.9	45.1	14500	28.3	78	20000	27.4	111	38000	27.0	213	58000	27.1	324	
3000	30.5	14.9	5000	31.3	24.2	8300	31.2	40.3	14500	32.1	69	20000	31.9	95	38000	30.5	189	58000	31.4	281	
3000	35.7	12.8	5000	34.5	22.0	8300	34.5	36.6	14500	34.6	64	20000	35.4	86	38000	35.1	164	58000	35.8	246	
3000	40.6	11.2	5000	37.8	20.1	8300	38.6	32.7	14500	39.3	56	20000	39.5	77	38000	38.7	149	58000	38.3	230	
3000	47.0	9.7	5000	44.6	17.0	8300	45.5	27.7	14500	45.8	48.1	20000	43.6	70	38000	42.9	134	58000	41.4	213	
3000	51.3	8.9	5000	50.0	15.2	8500	49.4	26.1	14500	50.9	43.3	20000	47.3	64	38000	47.8	121	58000	47.9	184	
3000	57.7	7.9	5000	53.4	14.2	9000	57.6	23.7	14500	56.7	38.8	20000	54.4	56	38000	54.2	106	58000	53.5	165	
3000	63.2	7.2	5000	61.1	12.4	9000	63.9	21.4	14500	62.6	35.1	20000	61.6	49.3	38000	60.2	96	58000	60.3	146	
3000	73.0	6.2	5000	67.9	11.2	9000	67.7	20.2	14500	68.0	32.4	20000	68.6	44.3	38000	68.8	84	58000	66.7	132	
3000	77.9	5.8	5000	77.1	9.9	9000	77.0	17.7	14500	78.1	28.2	20000	75.9	40.0	38000	78.1	74	58000	75.0	117	
3000	90.0	5.1	5000	86.4	8.8	9000	86.2	15.9	14500	88.5	24.9	20000	87.4	34.7	38000	86.8	67	58000	83.0	106	
3000	102.3	4.45	5000	98.6	7.7	9000	95.7	14.3	14500	98.5	22.3	20000	97.3	31.2	38000	98.6	59	58000	99.2	89	
3000	113.6	4.01	5000	105.1	7.2	9000	112.0	12.2	14500	109.1	20.2	20000	107.7	28.2	38000	113.1	51	58000	109.8	80	
3000	127.8	3.56	4300	120.8	5.4	9000	120.4	11.3	14500	127.3	17.3	20000	125.7	24.2	38000	127.9	45.1	58000	124.0	71	
3000	140.6	3.24	4300	135.8	4.81	9000	135.3	10.1	14500	135.0	16.3	20000	133.4	22.8	38000	140.4	41.1	58000	141.6	62	
2500	153.7	2.47	4300	150.0	4.35	8500	155.8	8.3	14500	153.1	14.4				38000	155.1	37.2	58000	159		

3.2 K/C组合型传动能力表
($n_{1N}=1450r/min, i_N=112\sim 14000$)

3.2 K&C Combi-type Transmission Capacity
($n_{1N}=1450r/min, i_N=112\sim 14000$)

公称输入转速	公称输出转速	公称减速比代号	公称减速比	额定输出扭矩	精确减速比	额定输入功率	额定输出扭矩	精确减速比	额定输入功率	额定输出扭矩	精确减速比	额定输入功率	
Nominal Input Speed	Nominal Output Speed	Nominal Ratio Code	Nominal Ratio	Rated Output Torque	Exact Ratio	Rated Input Power	Rated Output Torque	Exact Ratio	Rated Input Power	Rated Output Torque	Exact Ratio	Rated Input Power	
n_{1N} (r/min)	n_{2N} (r/min)	Code	i_N	T_{2N} (N.m)	i_{ex}	P_{1N} (kW)	T_{2N} (N.m)	i_{ex}	P_{1N} (kW)	T_{2N} (N.m)	i_{ex}	P_{1N} (kW)	
1450	12.90	D11	112	230	116.2	0.30	450	110.4	0.62	680	106.8	0.97	
	11.60	D13	125	230	129.5	0.27	450	126.5	0.54	680	122.4	0.84	
	10.36	D14	140	230	144.8	0.24	450	138.9	0.49	680	134.4	0.77	
	9.06	D16	160	230	153.7	0.23	450	156.2	0.44	680	151.2	0.68	
	K303/C301												
	8.06	D18	180	230	182.9	0.19	450	167.4	0.41	680	162.0	0.64	
	K304/C303												
	7.25	D20	200	230	209.6	0.17	450	189.7	0.36	680	183.6	0.56	
	6.47	D22	224	230	238.8	0.15	450	214.5	0.32	680	207.6	0.50	
	K303/C201												
	5.80	D25	250	230	248.3	0.14	450	264.1	0.26	680	265.5	0.39	
	5.18	D28	280	230	281.3	0.12	450	298.3	0.23	680	299.9	0.34	
	4.60	D32	315	230	332.1	0.11	450	331.1	0.21	680	332.9	0.31	
	4.08	D36	355	230	370.3		450	379.4	0.18	680	381.5	0.27	
	3.63	D40	400	230	413.8		450	416.6	0.16	680	418.9	0.25	
	3.22	D45	450	230	439.2		450	468.7	0.15	680	471.2	0.22	
	K303/C301												
	2.90	D50	500	230	522.7		450	502.2	0.14	680	504.9	0.20	
	K304/C303												
	2.59	D56	560	230	599.0		450	569.2	0.12	680	572.2	0.18	
	2.30	D63	630	230	682.4		450	643.6	0.11	680	647.0	0.16	
	2.04	D71	710	230	740.5		450	732.8		680	736.8	0.14	
	K305/C203												
	1.81	D80	800	230	805.9		450	825.8		680	830.3	0.12	
	1.61	D90	900	230	893.0		450	937.4		680	942.5	0.11	
	1.45	E10	1000	230	998.3		450	1001		680	1006		
	1.29	E11	1120	230	1172		450	1127		680	1133		
	1.16	E13	1250	230	1285		450	1283		680	1290		
	1.04	E14	1400	230	1394		450	1455		680	1462		
	0.91	E16	1600	230	1681		450	1644		680	1653		
	0.81	E18	1800	230	1880		450	1771		680	1780		
	0.73	E20	2000	230	1997		450	2072		680	2083		
	0.65	E22	2240	230	2207		450	2351		680	2364		
	0.58	E25	2500	230	2561		450	2581		680	2459		
	0.52	E28	2800	230	3088		450	2917		680	2780		
	0.46	E32	3150	230	3455		450	3142		680	2994		
	0.41	E36	3550	230	3669		450	3676		680	3504		
	0.36	E40	4000	230	4055		450	4171		680	3975		
	0.32	E45	4500	230	4756		450	4594		680	4378		
	0.29	E50	5000	230	5403		450	5023		680	4787		
0.26	E56	5600	230	5830		450	5491		680	5233			
0.23	E63	6300				450	6431		680	6257			
0.20	E71	7100				450	7032		680	6841			
0.18	E80	8000				450	7688		680	7480			
0.16	E90	9000											
0.15	F10	10000											
0.13	F11	11200											
0.12	F13	12500											
0.10	F14	14000											

额定输出扭矩	精确减速比	额定输入功率	额定输出扭矩	精确减速比	额定输入功率	额定输出扭矩	精确减速比	额定输入功率
Rated Output Torque	Exact Ratio	Rated Input Power	Rated Output Torque	Exact Ratio	Rated Input Power	Rated Output Torque	Exact Ratio	Rated Input Power
T_{2N} (N.m)	i_{ex}	P_{1N} (kW)	T_{2N} (N.m)	i_{ex}	P_{1N} (kW)	T_{2N} (N.m)	i_{ex}	P_{1N} (kW)
K306/C203			K307/C203			K308/C205		
950	115.7	1.25	1750	106.8	2.49	3000	113.3	4.02
950	132.6	1.09	1750	122.4	2.17	3000	120.8	3.77
950	145.6	0.99	1750	134.4	1.98	3000	135.0	3.37
950	163.8	0.88	1750	151.2	1.76	3000	150.0	3.04
K306/C303			K307/C303			K308/C305		
950	175.5	0.82	1750	162.0	1.64	3000	187.5	2.43
K306/C203			K307/C203			K308/C205		
950	198.9	0.73	1750	183.6	1.45	3000	205.0	2.22
950	224.9	0.64	1750	207.6	1.28	3000	233.8	1.95
K306/C203			K307/C203			K308/C205		
950	254.2	0.57	1750	250.6	1.06	3000	258.8	1.76
950	287.1	0.50	1750	283.1	0.94	3000	284.9	1.60
950	318.6	0.45	1750	314.2	0.85	3000	323.4	1.41
950	365.2	0.40	1750	360.1	0.74	3000	344.9	1.32
950	401.0	0.36	1750	395.4	0.67	3000	385.6	1.18
950	451.1	0.32	1750	444.8	0.60	3000	428.4	1.06
K306/C303			K307/C303			K308/C305		
950	483.3	0.30	1750	476.6	0.56	3000	535.5	0.85
K306/C203			K307/C203			K308/C205		
950	547.7	0.26	1750	540.1	0.49	3000	585.5	0.78
950	619.3	0.23	1750	610.7	0.44	3000	667.6	0.68
950	705.3	0.20	1750	695.4	0.38	3000	710.4	0.64
K306/C303			K307/C303			K308/C305		
950	794.8	0.18	1750	783.7	0.34	3000	799.7	0.57
950	902.2	0.16	1750	889.6	0.30	3000	899.6	0.51
950	963.0	0.15	1750	949.6	0.28	3000	1014	0.45
950	1085	0.13	1750	1070	0.25	3000	1125	0.41
950	1235	0.12	1750	1218	0.22	3000	1289	0.35
950	1400	0.10	1750	1380	0.19	3000	1417	0.32
950	1582		1750	1560	0.17	3000	1681	0.27
950	1704		1750	1680	0.16	3000	1867	0.24
950	1994		1750	1966	0.14	3000	2138	0.21
950	2263		1750	2231	0.12	3000	2349	0.19
950	2475		1750	2459	0.11	3000	2509	0.18
950	2798		1750	2780		3000	2977	0.15
950	3013		1750	2994		3000	3305	0.14
950	3526		1750	3504		3000	3786	0.12
950	4001		1750	3975		3000	4159	0.11
950	4406		1750	4378		3000	4689	
950	4817		1750	4787		3000	5012	
950	5267		1750	5233		3000	5827	
950	5819		1750	5860		3000	6678	
950	6362		1750	6408		3000	7137	
950	6956		1750	7005		3000	8298	
						3000	9333	
						3000	10197	
						3000	11178	
						3000	12150	

K/C组合型传动能力表
($n_{1N}=1450r/min, i_N=112\sim 14000$)

K&C Combi-type Transmission Capacity
($n_{1N}=1450r/min, i_N=112\sim 14000$)

公称输入转速 Nominal Input Speed	公称输出转速 Nominal Output Speed	公称减速比代号 Nominal Ratio Code	公称减速比 Nominal Ratio	额定输出扭矩 Rated Output Torque	精确减速比 Exact Ratio	额定输入功率 Rated Input Power	额定输出扭矩 Rated Output Torque	精确减速比 Exact Ratio	额定输入功率 Rated Input Power	额定输出扭矩 Rated Output Torque	精确减速比 Exact Ratio	额定输入功率 Rated Input Power	
n_{1N} (r/min)	n_{2N} (r/min)	Code	i_N	T_{2N} (N.m)	i_{ex}	P_{1N} (kW)	T_{2N} (N.m)	i_{ex}	P_{1N} (kW)	T_{2N} (N.m)	i_{ex}	P_{1N} (kW)	
1450	12.90	D11	112	5000	116.0	6.5	9000	112.6	12.1	14500	115.9	19.0	
	11.60	D13	125	5000	123.6	6.1	9000	128.8	10.6	14500	131.0	16.8	
	10.36	D14	140	5000	138.2	5.5	9000	145.0	9.4	14500	142.4	15.5	
					K310/C307								
	9.06	D16	160	5000	153.6	4.94	9000	157.5	8.7	14500	160.0	13.8	
	8.06	D18	180	5000	192.0	3.95	9000	181.3	7.5	14500	175.1	12.6	
	7.25	D20	200	5000	209.9	3.62	9000	192.5	7.1	14500	202.9	10.9	
	6.47	D22	224	5000	239.4	3.17	9000	221.3	6.2	14500	216.7	10.2	
								K310/C207			K312/C207		
	5.80	D25	250	5000	250.1	3.04	9000	246.3	5.5	14500	247.0	8.9	
	5.18	D28	280	5000	275.3	2.76	9000	280.5	4.87	14500	281.3	7.8	
	4.60	D32	315	5000	312.6	2.43	9000	310.8	4.40	14500	311.7	7.1	
	4.08	D36	355	5000	333.3	2.28	9000	355.4	3.85	14500	356.4	6.2	
	3.63	D40	400	5000	372.6	2.04	9000	400.2	3.41	14500	401.4	5.5	
								K310/C307			K312/C307		
	3.22	D45	450	5000	414.0	1.83	9000	434.7	3.14	14500	436.0	5.0	
	2.90	D50	500	5000	517.5	1.47	9000	500.3	2.73	14500	501.7	4.39	
	2.59	D56	560	5000	565.8	1.34	9000	531.3	2.57	14500	532.8	4.13	
	2.30	D63	630	5000	645.2	1.18	9000	610.7	2.24	14500	612.4	3.59	
	2.04	D71	710	5000	686.6	1.11	9000	714.2	1.91	14500	716.2	3.07	
					K309/C305								
	1.81	D80	800	5000	772.8	0.98	9000	800.4	1.71	14500	802.7	2.74	
	1.61	D90	900	5000	869.4	0.87	9000	914.3	1.49	14500	916.9	2.40	
	1.45	E10	1000	5000	979.8	0.77	9000	976.4	1.40	14500	979.2	2.25	
	1.29	E11	1120	5000	1087	0.70	9000	1118	1.22	14500	1121	1.96	
	1.16	E13	1250	5000	1245	0.61	9000	1273	1.07	14500	1277	1.72	
	1.04	E14	1400	5000	1370	0.55	9000	1311	1.04	14500	1315	1.67	
	0.91	E16	1600	5000	1625	0.47	9000	1504	0.91	14500	1509	1.46	
	0.81	E18	1800	5000	1804	0.42	9000	1708	0.80	14500	1713	1.29	
	0.73	E20	2000	5000	2067	0.37	9000	1911	0.71	14500	1917	1.15	
	0.65	E22	2240	5000	2270	0.33	9000	2129	0.64	14500	2135	1.03	
	0.58	E25	2500	5000	2426	0.31	9000	2428	0.56	14500	2379	0.93	
	0.52	E28	2800	5000	2878	0.26	9000	2786	0.49	14500	2729	0.81	
	0.46	E32	3150	5000	3196	0.24	9000	3163	0.43	14500	3099	0.71	
	0.41	E36	3550	5000	3660	0.21	9000	3540	0.39	14500	3468	0.63	
	0.36	E40	4000	5000	4020	0.19	9000	3943	0.35	14500	3862	0.57	
	0.32	E45	4500	5000	4534	0.17	9000	4332	0.32	14500	4244	0.52	
	0.29	E50	5000	5000	4845	0.16	9000	4920	0.28	14500	4820	0.46	
	0.26	E56	5600	5000	5633	0.13	9000	6122	0.22	14500	5997	0.37	
	0.23	E63	6300	5000	6411	0.12	9000	8775	0.16	14500	9009	0.24	
	0.20	E71	7100	5000	6852	0.11	9000	6637	0.21	14500	6815	0.32	
	0.18	E80	8000	5000	7966		9000	8258	0.17	14500	8478	0.26	
	0.16	E90	9000	5000	8960		9000	8775	0.16	14500	9009	0.24	
0.15	F10	10000	5000	9789		9000	10146	0.13	14500	10416	0.21		
0.13	F11	11200	5000	10731		9000	10732	0.13	14500	11018	0.20		
0.12	F13	12500	5000	11664		9000	12068	0.11	14500	12390	0.18		
0.10	F14	14000				9000	12835		14500	13178	0.17		

额定输出扭矩 Rated Output Torque	精确减速比 Exact Ratio	额定输入功率 Rated Input Power	额定输出扭矩 Rated Output Torque	精确减速比 Exact Ratio	额定输入功率 Rated Input Power	额定输出扭矩 Rated Output Torque	精确减速比 Exact Ratio	额定输入功率 Rated Input Power			
T_{2N} (N.m)	i_{ex}	P_{1N} (kW)	T_{2N} (N.m)	i_{ex}	P_{1N} (kW)	T_{2N} (N.m)	i_{ex}	P_{1N} (kW)			
K315/C210			K316/C210			K318/C210					
20000	115.8	26.2	38000	107.1	53.9	58000	114.0	77.2			
20000	129.6	23.4	38000	119.9	48.1	58000	127.6	69.0			
20000	143.4	21.2	38000	132.7	43.5	58000	141.2	62.3			
20000	167.5	18.1	38000	155.0	37.2	58000	165.0	53.4			
20000	184.9	16.4	38000	171.1	33.7	58000	182.2	48.3			
20000	195.6	15.5	38000	181.0	31.9	58000	192.7	45.7			
20000	222.4	13.7	38000	205.8	28.0	58000	219.1	40.2			
			K315/C209			K316/C209			K318/C209		
20000	249.9	12.2	38000	247.8	23.3	58000	252.7	34.8			
20000	277.9	10.9	38000	275.5	20.9	58000	281.0	31.3			
20000	315.4	9.6	38000	312.7	18.4	58000	319.0	27.6			
20000	357.5	8.5	38000	354.5	16.3	58000	361.6	24.4			
20000	403.6	7.5	38000	400.1	14.4	58000	408.1	21.6			
20000	428.3	7.1	38000	424.7	13.6	58000	433.2	20.3			
20000	492.1	6.2	38000	487.9	11.8	58000	497.6	17.7			
20000	545.2	5.6	38000	540.5	10.7	58000	551.3	16.0			
20000	619.5	4.90	38000	614.3	9.4	58000	626.5	14.1			
20000	693.8	4.38	38000	688.0	8.4	58000	701.7	12.6			
20000	793.0	3.83	38000	786.2	7.3	58000	801.9	11.0			
20000	846.1	3.59	38000	838.9	6.9	58000	855.6	10.3			
			K315/C309			K316/C309			K318/C309		
20000	987.7	3.07	38000	979.3	5.9	58000	998.8	8.8			
20000	1143	2.66	38000	1134	5.1	58000	1156	7.6			
20000	1246	2.44	38000	1236	4.67	58000	1260	7.0			
20000	1402	2.17	38000	1390	4.15	58000	1418	6.2			
20000	1536	1.98	38000	1523	3.79	58000	1554	5.7			
20000	1774	1.71	38000	1759	3.28	58000	1794	4.91			
20000	1894	1.60	38000	1878	3.07	58000	1915	4.60			
20000	2244	1.35	38000	2225	2.59	58000	2270	3.88			
20000	2439	1.24	38000	2384	2.42	58000	2388	3.69			
20000	2673	1.14	38000	2617	2.20	58000	2617	3.37			
20000	3086	0.98	38000	3026	1.91	58000	3021	2.91			
20000	3296	0.92	38000	3237	1.78	58000	3226	2.73			
20000	3905	0.78	38000	3842	1.50	58000	3823	2.30			
20000	4257	0.71	38000	4194	1.38	58000	4167	2.11			
20000	4792	0.63	38000	4730	1.22	58000	4691	1.88			
20000	5248	0.58	38000	5189	1.11	58000	5138	1.71			
20000	6039	0.50	38000	5998	0.96	58000	5735	1.54			
20000	6800	0.45	38000	6753	0.85	58000	6457	1.36			
20000	7446	0.41	38000	7395	0.78	58000	7072	1.25			
20000	8609	0.35	38000	8550	0.67	58000	8176	1.08			
20000	9177	0.33	38000	9114	0.63	58000	8715	1.01			
20000	10602	0.29	38000	10529	0.55	58000	10068	0.87			
20000	12052	0.25	38000	11970	0.48	58000	11446	0.77			
20000	13390	0.23	38000	13298	0.43	58000	12716	0.69			

3.4 K/C组合型传动能力表
($n_{1N}=1740\text{r/min}, i_N=112\sim 14000$)

3.4 K&C Combi-type Transmission Capacity
($n_{1N}=1740\text{ r/min}, i_N=112\sim 14000$)

公称输入转速 Nominal Input Speed n_{1N} (r/min)	公称输出转速 Nominal Output Speed n_{2N} (r/min)	公称减速比代号 Nominal Ratio Code Code	公称减速比 Nominal Ratio i_N	额定输出扭矩 Rated Output Torque T_{2N} (N.m)	精确减速比 Exact Ratio i_{ex}	额定输入功率 Rated Input Power P_{1N} (kW)	额定输出扭矩 Rated Output Torque T_{2N} (N.m)	精确减速比 Exact Ratio i_{ex}	额定输入功率 Rated Input Power P_{1N} (kW)	额定输出扭矩 Rated Output Torque T_{2N} (N.m)	精确减速比 Exact Ratio i_{ex}	额定输入功率 Rated Input Power P_{1N} (kW)	
1740	15.5	D11	112	230	116.2	0.36	450	110.4	0.74	680	106.8	1.16	
	13.9	D13	125	230	129.5	0.32	450	126.5	0.65	680	122.4	1.01	
	12.4	D14	140	230	144.8	0.29	450	138.9	0.59	680	134.4	0.92	
	10.9	D16	160	230	153.7	0.27	450	156.2	0.52	680	151.2	0.82	
	K303/C201												
	9.7	D18	180	230	182.9	0.23	450	167.4	0.49	680	162.0	0.76	
	K304/C203												
	8.70	D20	200	230	209.6	0.20	450	189.7	0.43	680	183.6	0.67	
	7.77	D22	224	230	238.8	0.18	450	214.5	0.38	680	207.6	0.60	
	K305/C203												
	6.96	D25	250	230	248.3	0.17	450	264.1	0.31	680	265.5	0.47	
	6.21	D28	280	230	281.3	0.15	450	298.3	0.27	680	299.9	0.41	
	5.52	D32	315	230	332.1	0.13	450	331.1	0.25	680	332.9	0.37	
	4.90	D36	355	230	370.3		450	379.4	0.22	680	381.5	0.32	
	4.35	D40	400	230	413.8		450	416.6	0.20	680	418.9	0.30	
	3.87	D45	450	230	439.2		450	468.7	0.17	680	471.2	0.26	
	K303/C301												
	3.48	D50	500	230	522.7		450	502.2	0.16	680	504.9	0.25	
	K304/C303												
	3.11	D56	560	230	599.0		450	569.2	0.14	680	572.2	0.22	
	2.76	D63	630	230	682.4		450	643.6	0.13	680	647.0	0.19	
	2.45	D71	710	230	740.5		450	732.8		680	736.8	0.17	
	K305/C303												
	2.18	D80	800	230	805.9		450	825.8		680	830.3	0.15	
	1.93	D90	900	230	893.0		450	937.4		680	942.5	0.13	
	1.74	E10	1000	230	998.3		450	1001		680	1006		
	1.55	E11	1120	230	1172		450	1127		680	1133		
	1.39	E13	1250	230	1285		450	1283		680	1290		
	1.24	E14	1400	230	1394		450	1455		680	1462		
	1.09	E16	1600	230	1681		450	1644		680	1653		
	0.97	E18	1800	230	1880		450	1771		680	1780		
	0.87	E20	2000	230	1997		450	2072		680	2083		
	0.78	E22	2240	230	2207		450	2351		680	2364		
	0.70	E25	2500	230	2561		450	2581		680	2459		
	0.62	E28	2800	230	3088		450	2917		680	2780		
	0.55	E32	3150	230	3455		450	3142		680	2994		
	0.49	E36	3550	230	3669		450	3676		680	3504		
	0.44	E40	4000	230	4055		450	4171		680	3975		
	0.39	E45	4500	230	4756		450	4594		680	4378		
	0.35	E50	5000	230	5403		450	5023		680	4787		
	0.31	E56	5600	230	5830		450	5491		680	5233		
	0.28	E63	6300				450	6431		680	6257		
0.25	E71	7100				450	7032		680	6841			
0.22	E80	8000				450	7688		680	7480			
0.19	E90	9000											
0.17	F10	10000											
0.16	F11	11200											
0.14	F13	12500											
0.12	F14	14000											

额定输出扭矩 Rated Output Torque T_{2N} (N.m)	精确减速比 Exact Ratio i_{ex}	额定输入功率 Rated Input Power P_{1N} (kW)	额定输出扭矩 Rated Output Torque T_{2N} (N.m)	精确减速比 Exact Ratio i_{ex}	额定输入功率 Rated Input Power P_{1N} (kW)	额定输出扭矩 Rated Output Torque T_{2N} (N.m)	精确减速比 Exact Ratio i_{ex}	额定输入功率 Rated Input Power P_{1N} (kW)
K306/C203			K307/C203			K308/C205		
950	115.7	1.50	1750	106.8	2.99	3000	113.3	4.83
950	132.6	1.31	1750	122.4	2.60	3000	120.8	4.53
950	145.6	1.19	1750	134.4	2.37	3000	135.0	4.05
950	163.8	1.06	1750	151.2	2.11	3000	150.0	3.64
K303/C301								
950	175.5	0.99	1750	162.0	1.97	3000	187.5	2.92
K304/C303								
K306/C303			K307/C303					
950	198.9	0.87	1750	183.6	1.74	3000	205.0	2.67
950	224.9	0.77	1750	207.6	1.54	3000	233.8	2.34
K305/C203								
K306/C203			K307/C203					
950	254.2	0.68	1750	250.6	1.27	3000	258.8	2.11
950	287.1	0.60	1750	283.1	1.13	3000	284.9	1.92
950	318.6	0.54	1750	314.2	1.01	3000	323.4	1.69
950	365.2	0.47	1750	360.1	0.89	3000	344.9	1.58
950	401.0	0.43	1750	395.4	0.81	3000	385.6	1.42
950	451.1	0.38	1750	444.8	0.72	3000	428.4	1.28
K303/C301								
950	483.3	0.36	1750	476.6	0.67	3000	535.5	1.02
K304/C303								
K306/C303			K307/C303					
950	547.7	0.32	1750	540.1	0.59	3000	585.5	0.93
950	619.3	0.28	1750	610.7	0.52	3000	667.6	0.82
950	705.3	0.25	1750	695.4	0.46	3000	710.4	0.77
K305/C303								
950	794.8	0.22	1750	783.7	0.41	3000	799.7	0.68
950	902.2	0.19	1750	889.6	0.36	3000	899.6	0.61
950	963.0	0.18	1750	949.6	0.34	3000	1014	0.54
950	1085	0.16	1750	1070	0.30	3000	1125	0.49
950	1235	0.14	1750	1218	0.26	3000	1289	0.42
950	1400	0.12	1750	1380	0.23	3000	1417	0.39
950	1582		1750	1560	0.20	3000	1681	0.33
950	1704		1750	1680	0.19	3000	1867	0.29
950	1994		1750	1966	0.16	3000	2138	0.26
950	2263		1750	2231	0.14	3000	2349	0.23
950	2475		1750	2459	0.13	3000	2509	0.22
950	2798		1750	2780		3000	2977	0.18
950	3013		1750	2994		3000	3305	0.17
950	3526		1750	3504		3000	3786	0.14
950	4001		1750	3975		3000	4159	0.13
950	4406		1750	4378		3000	4689	
950	4817		1750	4787		3000	5012	
950	5267		1750	5233		3000	5827	
950	5819		1750	5860		3000	6678	
950	6362		1750	6408		3000	7137	
950	6956		1750	7005		3000	8298	
						3000	9333	
						3000	10197	
						3000	11178	
						3000	12150	

K/C组合型传动能力表
($n_{1N}=11740r/min, i_N=112\sim 14000$)

K&C Combi-type Transmission Capacity
($n_{1N}=11740 r/min, i_N=112\sim 14000$)

公称 输入转速 Nominal Input Speed	公称 输出转速 Nominal Output Speed	公称减速 比代号 Nominal Ratio Code	公称 减速比 Nominal Ratio	额定输出 扭矩 Rated Output Torque	精确 减速比 Exact Ratio	额定输入 功率 Rated Input Power	额定输出 扭矩 Rated Output Torque	精确 减速比 Exact Ratio	额定输入 功率 Rated Input Power	额定输出 扭矩 Rated Output Torque	精确 减速比 Exact Ratio	额定输入 功率 Rated Input Power	
n_{1N} (r/min)	n_{2N} (r/min)	Code	i_N	T_{2N} (N.m)	i_{ex}	P_{1N} (kW)	T_{2N} (N.m)	i_{ex}	P_{1N} (kW)	T_{2N} (N.m)	i_{ex}	P_{1N} (kW)	
1740	15.5	D11	112	5000	116.0	7.9	9000	112.6	14.6	14500	115.9	22.8	
	13.9	D13	125	5000	123.6	7.4	9000	128.8	12.7	14500	131.0	20.2	
	12.4	D14	140	5000	138.2	6.6	9000	145.0	11.3	14500	142.4	18.6	
	10.9	D16	160	5000	153.6	5.93	9000	157.5	10.4	14500	160.0	16.5	
	9.7	D18	180	5000	192.0	4.74	9000	181.3	9.0	14500	175.1	15.1	
	8.70	D20	200	5000	209.9	4.34	9000	192.5	8.5	14500	202.9	13.0	
	7.77	D22	224	5000	239.4	3.81	9000	221.3	7.4	14500	216.7	12.2	
	6.96	D25	250	5000	250.1	3.64	9000	246.3	6.7	14500	247.0	10.7	
	6.21	D28	280	5000	275.3	3.31	9000	280.5	5.85	14500	281.3	9.4	
	5.52	D32	315	5000	312.6	2.91	9000	310.8	5.28	14500	311.7	8.5	
	4.90	D36	355	5000	333.3	2.73	9000	355.4	4.61	14500	356.4	7.4	
	4.35	D40	400	5000	372.6	2.44	9000	400.2	4.10	14500	401.4	6.6	
	3.87	D45	450	5000	414.0	2.20	9000	434.7	3.77	14500	436.0	6.1	
	3.48	D50	500	5000	517.5	1.76	9000	500.3	3.28	14500	501.7	5.27	
	3.11	D56	560	5000	565.8	1.61	9000	531.3	3.09	14500	532.8	4.96	
	2.76	D63	630	5000	645.2	1.41	9000	610.7	2.69	14500	612.4	4.31	
	2.45	D71	710	5000	686.6	1.33	9000	714.2	2.30	14500	716.2	3.69	
	2.18	D80	800	5000	772.8	1.18	9000	800.4	2.05	14500	802.7	3.29	
	1.93	D90	900	5000	869.4	1.05	9000	914.3	1.79	14500	916.9	2.88	
	1.74	E10	1000	5000	979.8	0.93	9000	976.4	1.68	14500	979.2	2.70	
	1.55	E11	1120	5000	1087	0.84	9000	1118	1.47	14500	1121	2.36	
	1.39	E13	1250	5000	1245	0.73	9000	1273	1.29	14500	1277	2.07	
	1.24	E14	1400	5000	1370	0.67	9000	1311	1.25	14500	1315	2.01	
	1.09	E16	1600	5000	1625	0.56	9000	1504	1.09	14500	1509	1.75	
	0.97	E18	1800	5000	1804	0.50	9000	1708	0.96	14500	1713	1.54	
	0.87	E20	2000	5000	2067	0.44	9000	1911	0.86	14500	1917	1.38	
	0.78	E22	2240	5000	2270	0.40	9000	2129	0.77	14500	2135	1.24	
	0.70	E25	2500	5000	2426	0.38	9000	2428	0.68	14500	2379	1.11	
	0.62	E28	2800	5000	2878	0.32	9000	2786	0.59	14500	2729	0.97	
	0.55	E32	3150	5000	3196	0.29	9000	3163	0.52	14500	3099	0.85	
	0.49	E36	3550	5000	3660	0.25	9000	3540	0.46	14500	3468	0.76	
	0.44	E40	4000	5000	4020	0.23	9000	3943	0.42	14500	3862	0.68	
	0.39	E45	4500	5000	4534	0.20	9000	4332	0.38	14500	4244	0.62	
	0.35	E50	5000	5000	4845	0.19	9000	4920	0.33	14500	4820	0.55	
	0.31	E56	5600	5000	5633	0.16	9000	6122	0.27	14500	5997	0.44	
	0.28	E63	6300	5000	6411	0.14	9000	8775	0.19	14500	9009	0.29	
	0.25	E71	7100	5000	6852	0.13	9000	6637	0.25	14500	6815	0.39	
	0.22	E80	8000	5000	7966		9000	8258	0.20	14500	8478	0.31	
	0.19	E90	9000	5000	8960		9000	8775	0.19	14500	9009	0.29	
	0.17	F10	10000	5000	9789		9000	10146	0.16	14500	10416	0.25	
	0.16	F11	11200	5000	10731		9000	10732	0.15	14500	11018	0.24	
0.14	F13	12500	5000	11664		9000	12068	0.14	14500	12390	0.21		
0.12	F14	14000				9000	12835		14500	13178	0.20		

额定输出 扭矩 Rated Output Torque	精确 减速比 Exact Ratio	额定输入 功率 Rated Input Power	额定输出 扭矩 Rated Output Torque	精确 减速比 Exact Ratio	额定输入 功率 Rated Input Power	额定输出 扭矩 Rated Output Torque	精确 减速比 Exact Ratio	额定输入 功率 Rated Input Power
T_{2N} (N.m)	i_{ex}	P_{1N} (kW)	T_{2N} (N.m)	i_{ex}	P_{1N} (kW)	T_{2N} (N.m)	i_{ex}	P_{1N} (kW)
K315/C210			K316/C210			K318/C210		
20000	115.8	31.5	38000	107.1	64.6	58000	114.0	92.7
20000	129.6	28.1	38000	119.9	57.7	58000	127.6	82.8
20000	143.4	25.4	38000	132.7	52.2	58000	141.2	74.8
20000	167.5	21.8	38000	155.0	44.7	58000	165.0	64.0
20000	184.9	19.7	38000	171.1	40.5	58000	182.2	58.0
20000	195.6	18.6	38000	181.0	38.2	58000	192.7	54.8
20000	222.4	16.4	38000	205.8	33.6	58000	219.1	48.2
K315/C209			K316/C209			K318/C209		
20000	249.9	14.6	38000	247.8	27.9	58000	252.7	41.8
20000	277.9	13.1	38000	275.5	25.1	58000	281.0	37.6
20000	315.4	11.6	38000	312.7	22.1	58000	319.0	33.1
20000	357.5	10.2	38000	354.5	19.5	58000	361.6	29.2
20000	403.6	9.0	38000	400.1	17.3	58000	408.1	25.9
20000	428.3	8.5	38000	424.7	16.3	58000	433.2	24.4
20000	492.1	7.4	38000	487.9	14.2	58000	497.6	21.2
20000	545.2	6.7	38000	540.5	12.8	58000	551.3	19.2
20000	619.5	5.88	38000	614.3	11.3	58000	626.5	16.9
20000	693.8	5.25	38000	688.0	10.1	58000	701.7	15.1
20000	793.0	4.60	38000	786.2	8.8	58000	801.9	13.2
20000	846.1	4.31	38000	838.9	8.3	58000	855.6	12.4
K315/C309			K316/C309			K318/C309		
20000	987.7	3.69	38000	979.3	7.1	58000	998.8	10.6
20000	1143	3.19	38000	1134	6.1	58000	1156	9.1
20000	1246	2.92	38000	1236	5.60	58000	1260	8.4
20000	1402	2.60	38000	1390	4.98	58000	1418	7.5
20000	1536	2.37	38000	1523	4.54	58000	1554	6.8
20000	1774	2.05	38000	1759	3.94	58000	1794	5.89
20000	1894	1.92	38000	1878	3.69	58000	1915	5.52
20000	2244	1.62	38000	2225	3.11	58000	2270	4.66
20000	2439	1.49	38000	2384	2.90	58000	2388	4.43
20000	2673	1.36	38000	2617	2.65	58000	2617	4.04
20000	3086	1.18	38000	3026	2.29	58000	3021	3.50
20000	3296	1.11	38000	3237	2.14	58000	3226	3.28
20000	3905	0.93	38000	3842	1.80	58000	3823	2.76
20000	4257	0.86	38000	4194	1.65	58000	4167	2.54
20000	4792	0.76	38000	4730	1.46	58000	4691	2.25
20000	5248	0.69	38000	5189	1.33	58000	5138	2.06
20000	6039	0.60	38000	5998	1.15	58000	5735	1.84
20000	6800	0.54	38000	6753	1.03	58000	6457	1.64
20000	7446	0.49	38000	7395	0.94	58000	7072	1.49
20000	8609	0.42	38000	8550	0.81	58000	8176	1.29
20000	9177	0.40	38000	9114	0.76	58000	8715	1.21
20000	10602	0.34	38000	10529	0.66	58000	10068	1.05
20000	12052	0.30	38000	11970	0.58	58000	11446	0.92
20000	13390	0.27	38000	13298	0.52	58000	12716	0.83

4 允许的径向力表

4.1 输入轴径向力Fr1(N)

4 Permissible Radial Force

4.1 Radial Force of Input Shaft Fr1(N)

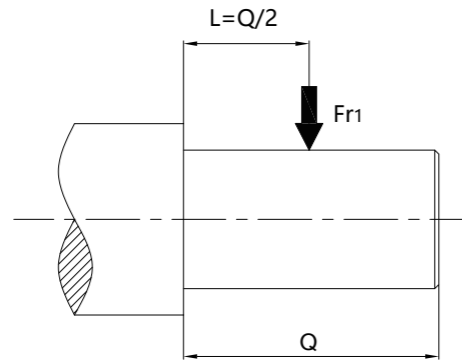

	Fr1 (N)											
	K303	K304	K305	K306	K307	K308	K309	K310	K312	K315	K316	K318
AE2	803	803	803	803	803	803	/	/	/	/	/	/
AE3	/	1504	1504	1504	1504	1504	1504	1504	/	/	/	/
AE4	/	/	/	/	2188	2188	2188	2188	2188	/	/	/
AE5	/	/	/	/	/	4207	4207	4207	4207	4207	4207	4207
AE6	/	/	/	/	/	/	5664	5664	5664	5664	5664	5664
AE7	/	/	/	/	/	/	/	/	9957	9957	9957	9957
AE8	/	/	/	/	/	/	/	/	12546	12546	12546	12546

4.2 输出轴径向力Fr2(N)

4.2 Radial Force of Output Shaft Fr2(N)

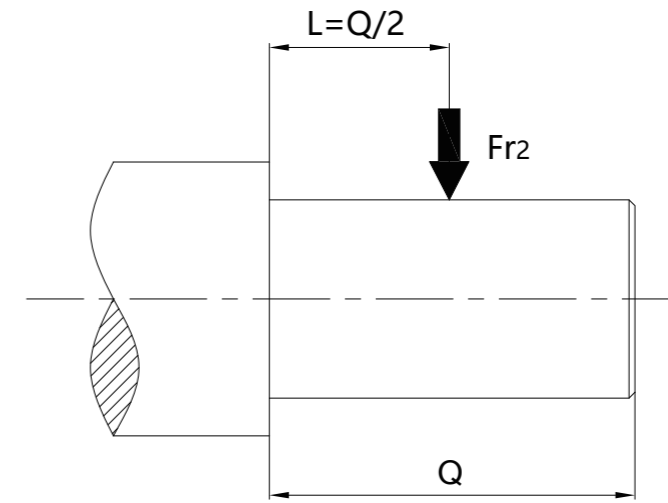

n _{2N} (r/min)	Fr2 (N)											
	K303	K304	K305	K306	K307	K308	K309	K310	K312	K315	K316	K318
315~425	1466	2430	4330	7715	/	/	/	/	/	/	/	/
280~315	1600	2650	4720	8410	/	/	/	/	/	/	/	/
225~280	1750	2890	5150	9165	/	/	/	/	/	/	/	/
160~225	1899	3150	5610	9990	11135	12150	14220	22140	29250	/	/	/
140~160	2070	3240	5791	10350	12510	12780	14760	23220	29700	30400	52180	58530
125~140	2250	3510	6105	10620	12960	13410	14580	24300	30510	31920	54790	61450
112~125	2340	3348	6088	11070	13590	13320	14470	25200	31860	33520	57500	64530
90~112	2430	3510	6001	10260	13500	13770	15300	19710	28620	35190	60400	67750
80~90	2610	3807	6139	9900	14490	14670	16020	21240	30240	36950	63420	71140
71~80	2799	3960	6204	9720	14130	15120	17190	23490	31500	38800	66600	74700
63~71	2880	4239	6419	9720	13860	16110	18810	26010	34200	42300	69750	76770
56~63	2997	4500	6490	9360	13860	16200	19800	28800	36900	46800	73500	78120
50~56	3150	4770	6650	9270	13860	16650	20970	29700	38700	48600	79740	81180
45~50	3285	5040	6835	9270	13860	17280	22050	31500	41340	51300	81900	85050
35.5~45	3375	5328	7028	9270	13860	19260	23130	33300	44460	54000	89730	92700
31.5~35.5	3960	5328	7028	9270	13860	20520	25470	36450	48600	60300	96660	101430
28~31.5	4194	5328	7028	9270	13860	21150	27900	37980	52200	65250	105300	113400
25~28	4410	5328	7028	9270	13860	22500	29070	39960	53910	67410	108000	113490
22.4~25	4662	5328	7028	9270	13860	23580	30420	41220	57600	71100	114300	123300
20~22.4	4968	5328	7028	9270	13860	24570	32040	43200	60930	75780	126000	130500
18~20	5076	5328	7028	9270	13860	24570	33390	45450	63000	79200	126090	132300
16~18	5076	5328	7028	9270	13860	24570	34920	47700	66150	82710	132480	143100
≤16	5076	5328	7028	9270	13860	24570	36000	51300	71280	88200	135000	152910

5 外形尺寸图
5.1 K303~K318+MP

5 Dimensions
5.1 K303~K318+MP

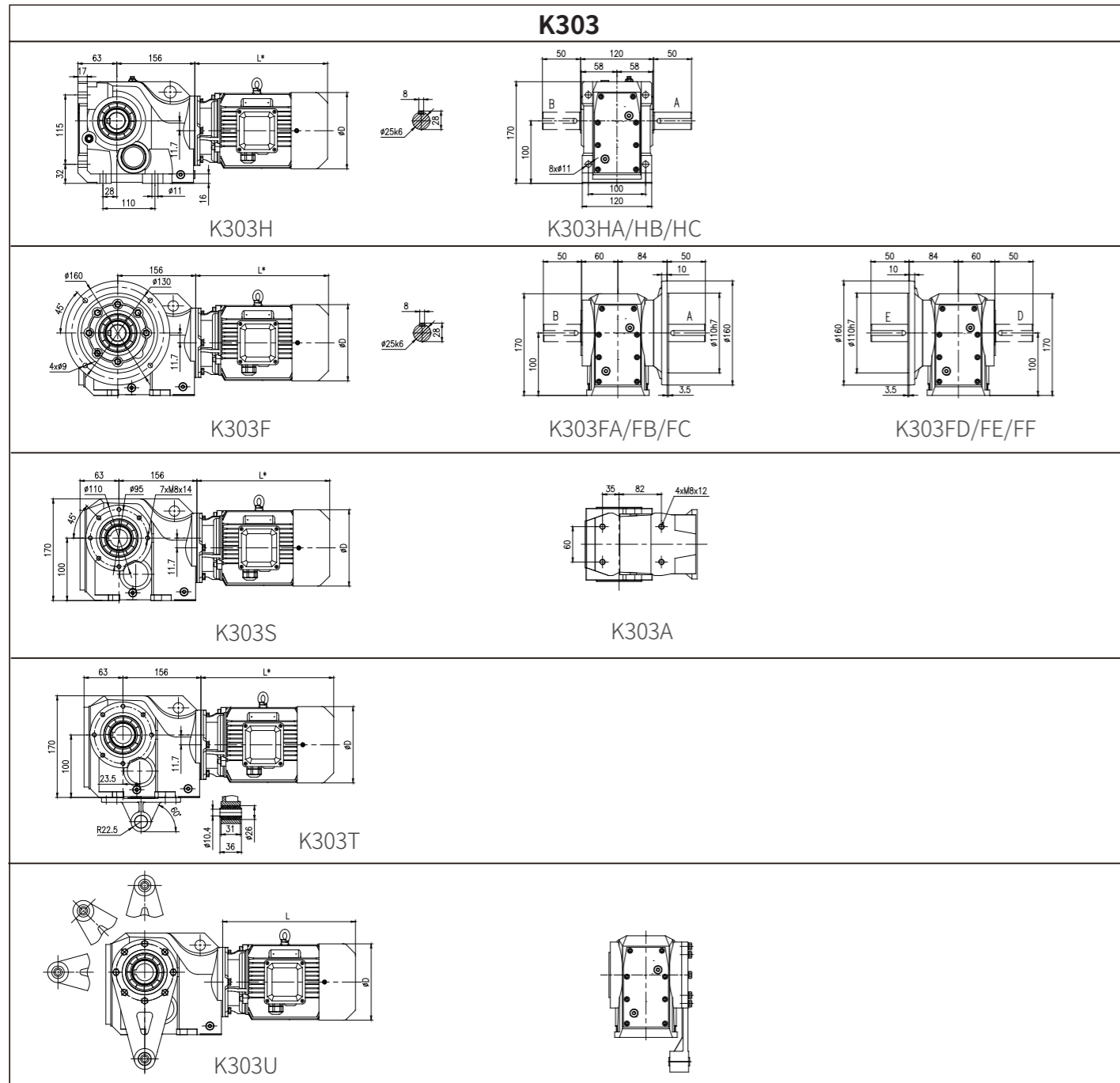

MP motor dimension for K303

Motor Type	P ₁ /kW	i _n	MP							D
			L1	L2	L3	L5	L6	L7		
Fan	0.12	4-100	206	261	241	296	/	/	124	
Driven fan	0.18	4-100	206	261	241	296	/	/	124	
Brake + fan	0.25	4-100	223	268	263	313	313	353	139	
Double brake	0.37	4-100	223	268	263	313	313	353	139	
Brake + Driven fan	0.55	4-71	299	344	359	404	404	454	162	
Encoder + Driven fan	0.75	4-56	299	344	359	404	404	454	162	
Brake + Encoder + Driven fan	1.1	4-35.5	322	367	377	422	422	477	176	
	1.5	4-28	347	392	402	447	447	502	176	
	2.2	4-16	394	434	469	509	509	564	202	
	3	4-11.2	394	434	469	509	509	564	202	

注:渐开线花键空心轴的花键规格DIN5480: Note: Involute spline size DIN5480:
m1.25×z22×α30×D30×9H m1.25×z22×α30×D30×9H

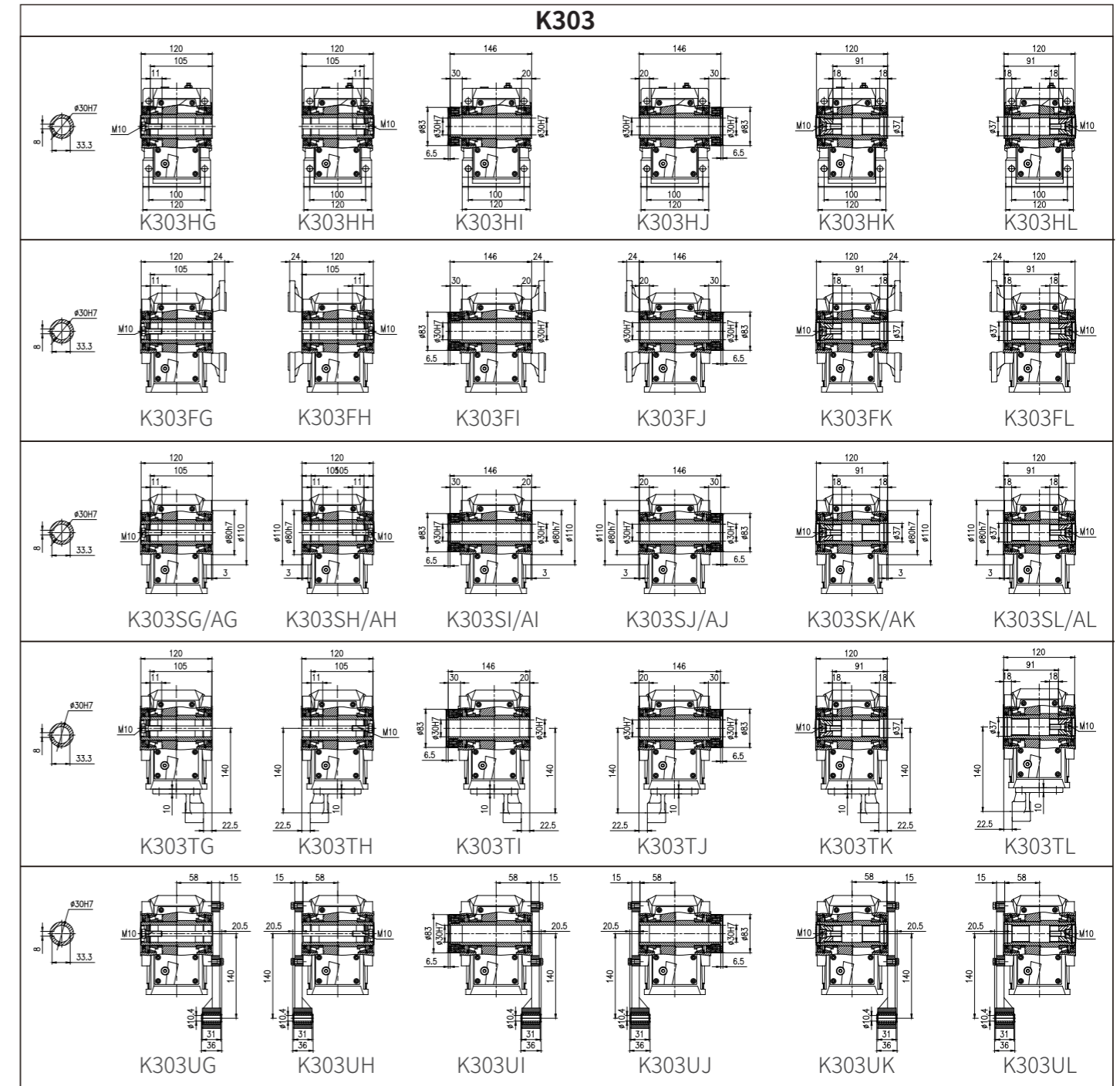

K303/C.01

MP motor dimension for K303/C.01

Motor Type	P ₁ /kW	i _n	MP							D
			L1	L2	L3	L5	L6	L7		
K303/C201	0.12	112-500	206	/	241	/	/	/	124	
K303/C301	0.18	112-250	198	/	233	/	/	/	124	
	0.25	112-224	221	/	256	/	/	/	139	
	0.37	112-140	221	/	256	/	/	/	139	

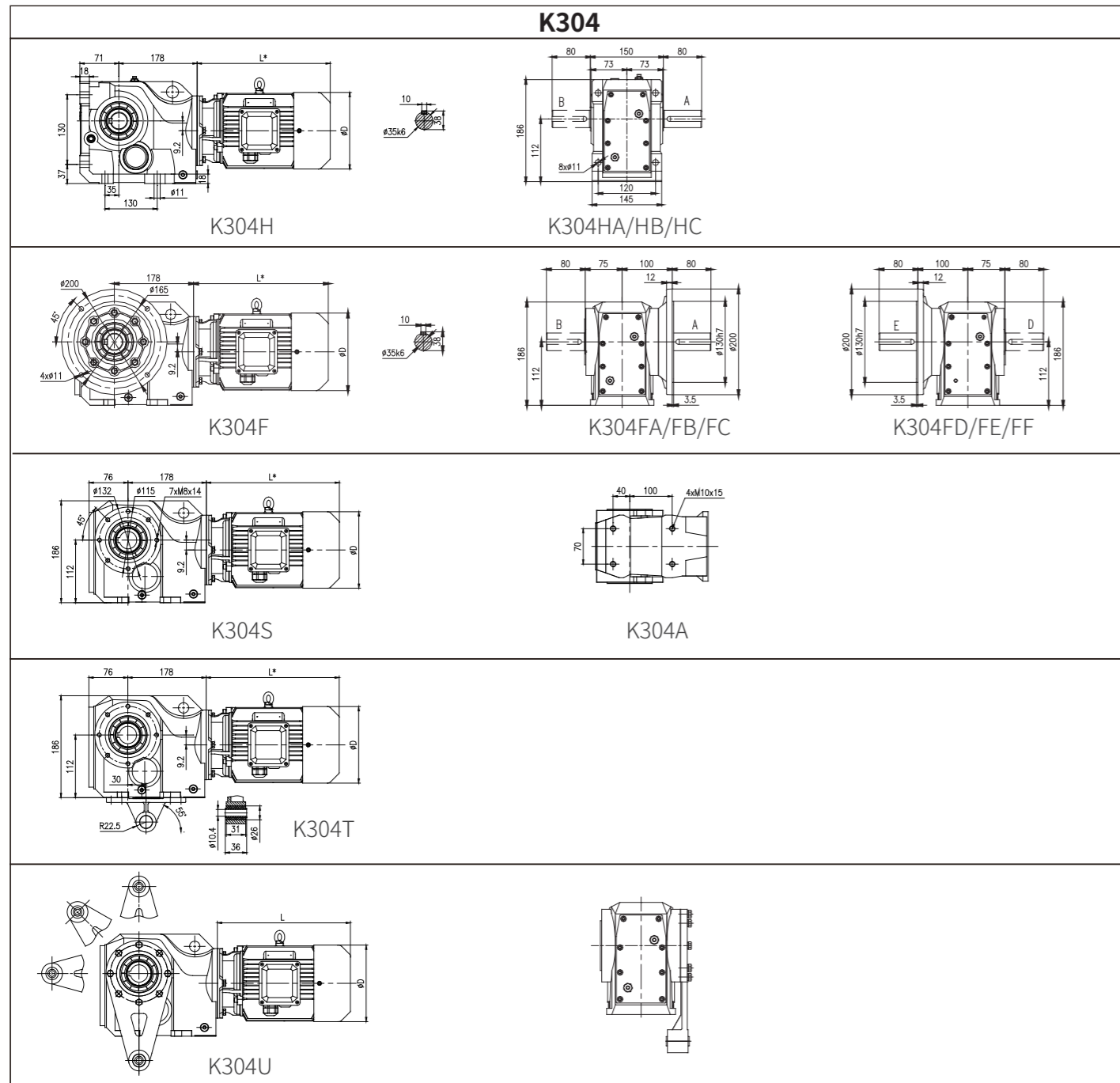

注:渐开线花键空心轴的花键规格DIN5480: Note: Involute spline size DIN5480:
m2×z16×α30×D35×9H m2×z16×α30×D35×9H

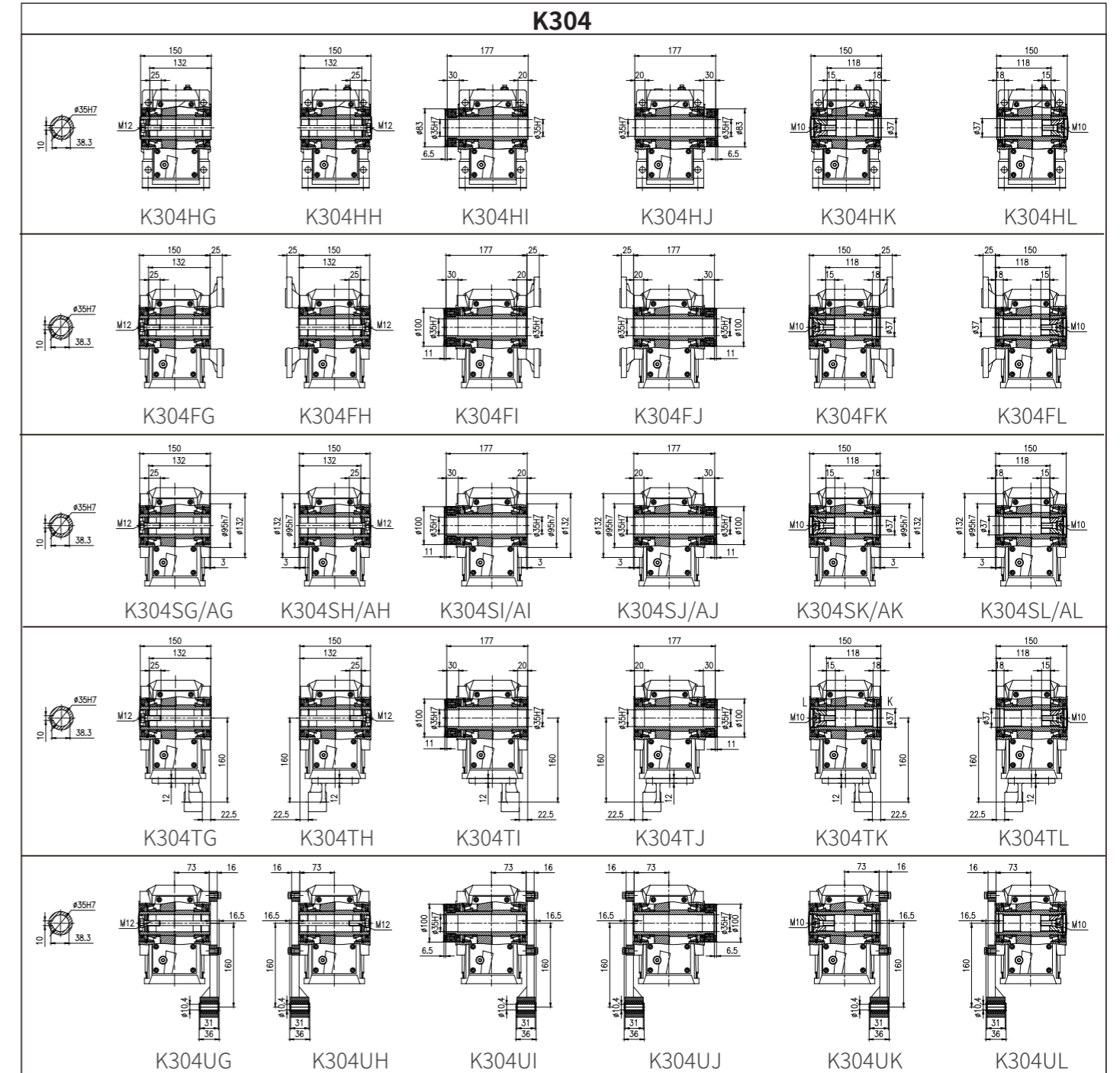

K304/C.03

MP motor dimension for K304/C.03

	P ₁ /kW	i _N	MP							D
			L1	L2	L3	L5	L6	L7		
	0.12	112-900	206	/	241	/	/	/	124	
	0.18	112-630	206	/	241	/	/	/	124	
	0.25	112-250	228	/	263	/	/	/	139	
	0.37	112-250	228	/	263	/	/	/	139	
	0.55	112-200	299	/	359	/	/	/	162	

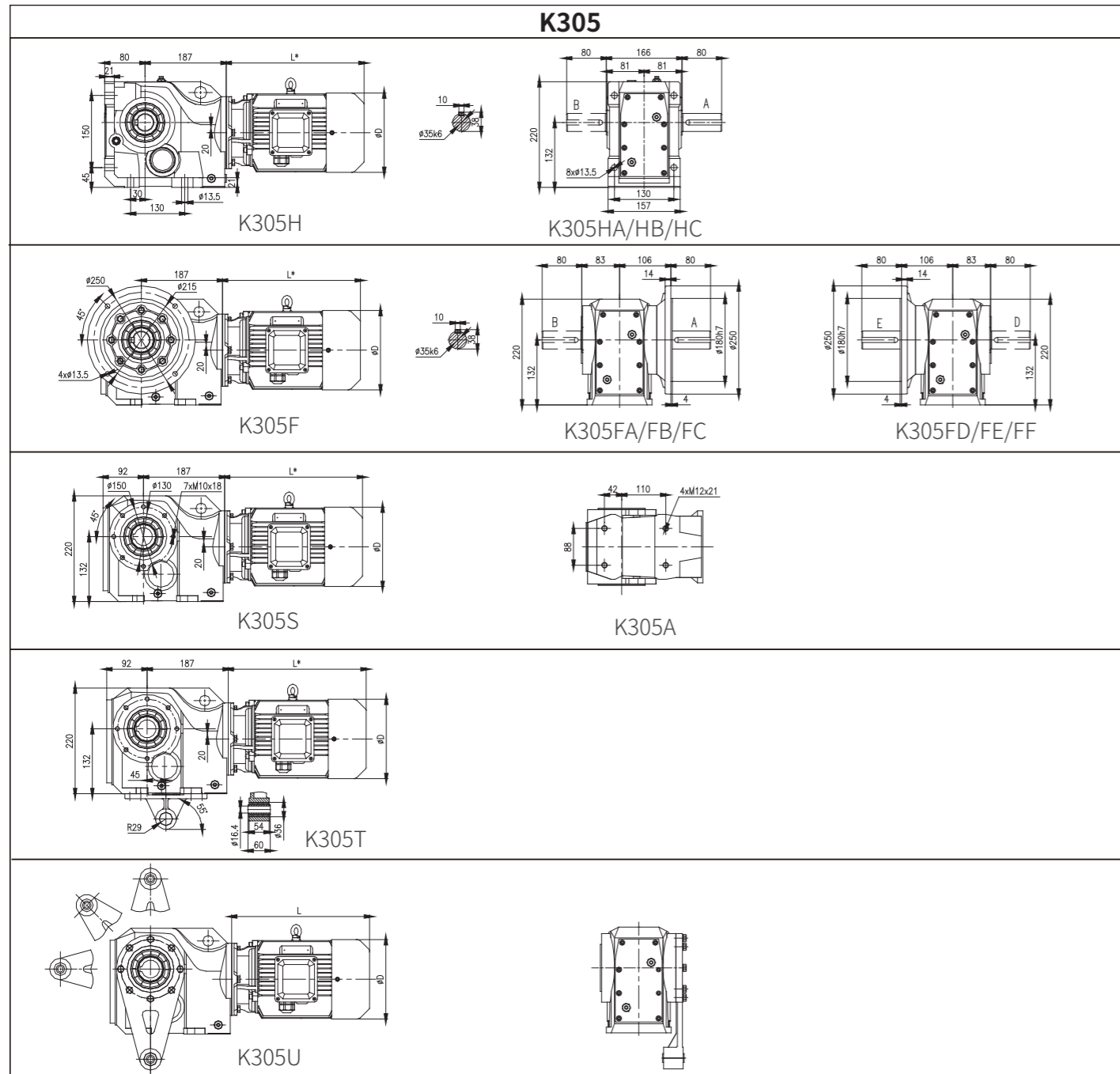

MP motor dimension for K305

MP	P ₁ /kW	i _N	MP							D
			L1	L2	L3	L5	L6	L7		
Fan	0.25	71-112	224	269	264	314	314	354	139	
Driven fan	0.37	63-112	224	269	264	314	314	354	139	
Brake + fan	0.55	40-112	300	345	360	405	405	455	162	
Double brake	0.75	31.5-112	300	345	360	405	405	455	162	
Brake + Driven fan	1.1	25-63	323	368	378	423	423	478	176	
Encoder + Driven fan	1.5	16-63	348	393	403	448	448	503	176	
Brake + Encoder + Driven fan	2.2	6.3-56	395	435	470	510	510	565	202	
	3	4-40	395	435	470	510	510	565	202	
	4	4-28	459	509	534	584	584	639	220	

注:渐开线花键空心轴的花键规格DIN5480: Note: Involute spline size DIN5480: m2×z16×α30×D35×9H

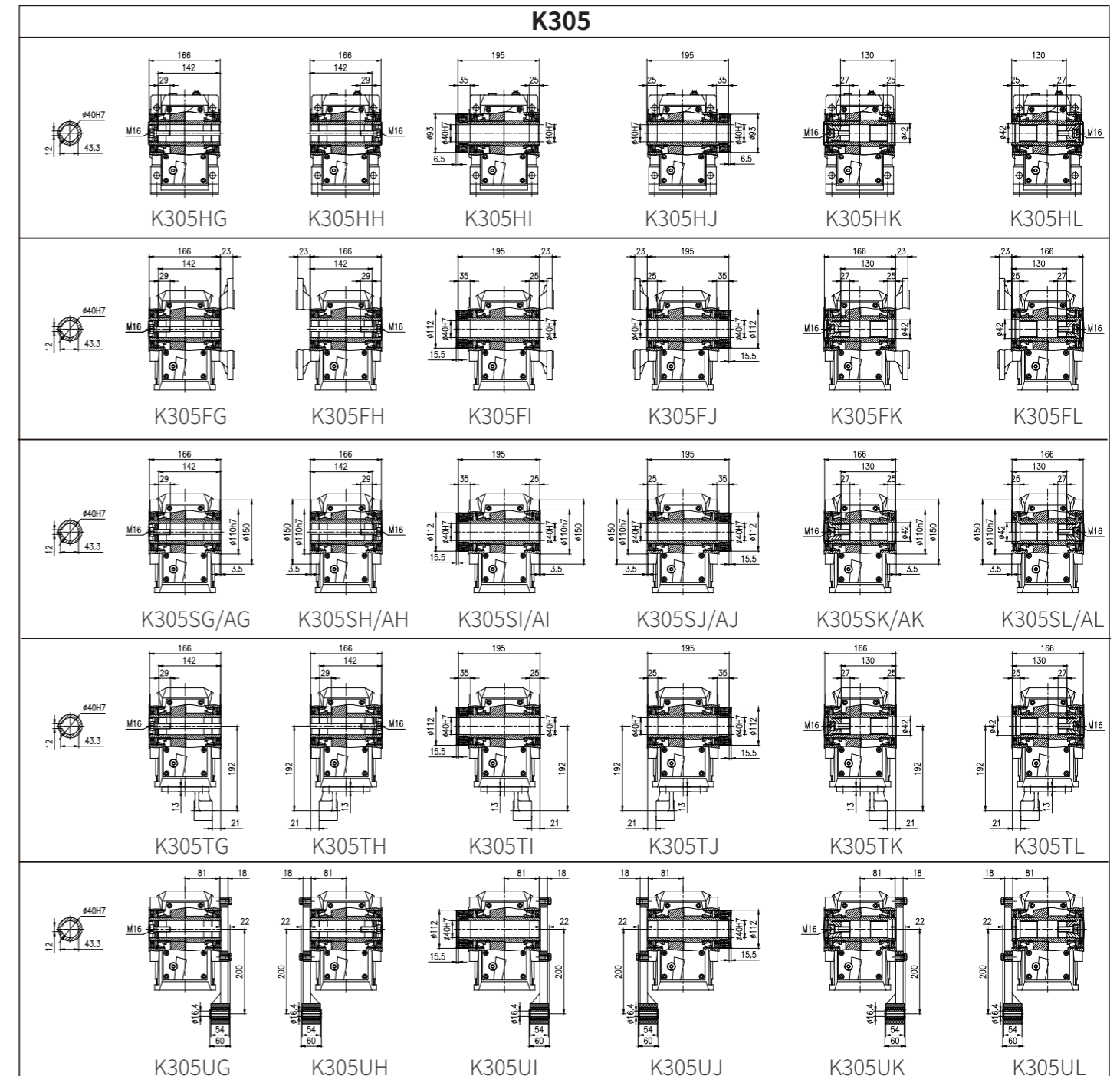

K305/C.03

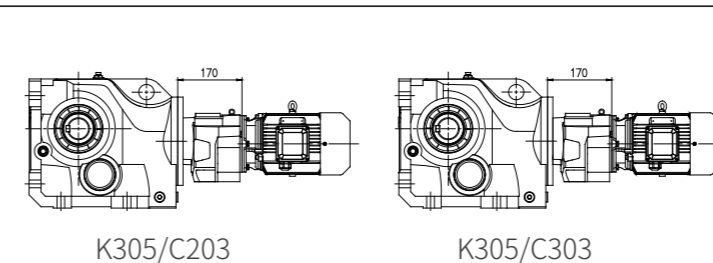

MP motor dimension for K305/C.03

MP	P ₁ /kW	i _N	MP							D
			L1	L2	L3	L5	L6	L7		
	0.12	112-1600	206	/	241	/	/	/	124	
	0.18	112-900	206	/	241	/	/	/	124	
	0.25	112-250	228	/	263	/	/	/	139	
	0.37	112-250	228	/	263	/	/	/	139	
	0.55	112-250	299	/	359	/	/	/	162	

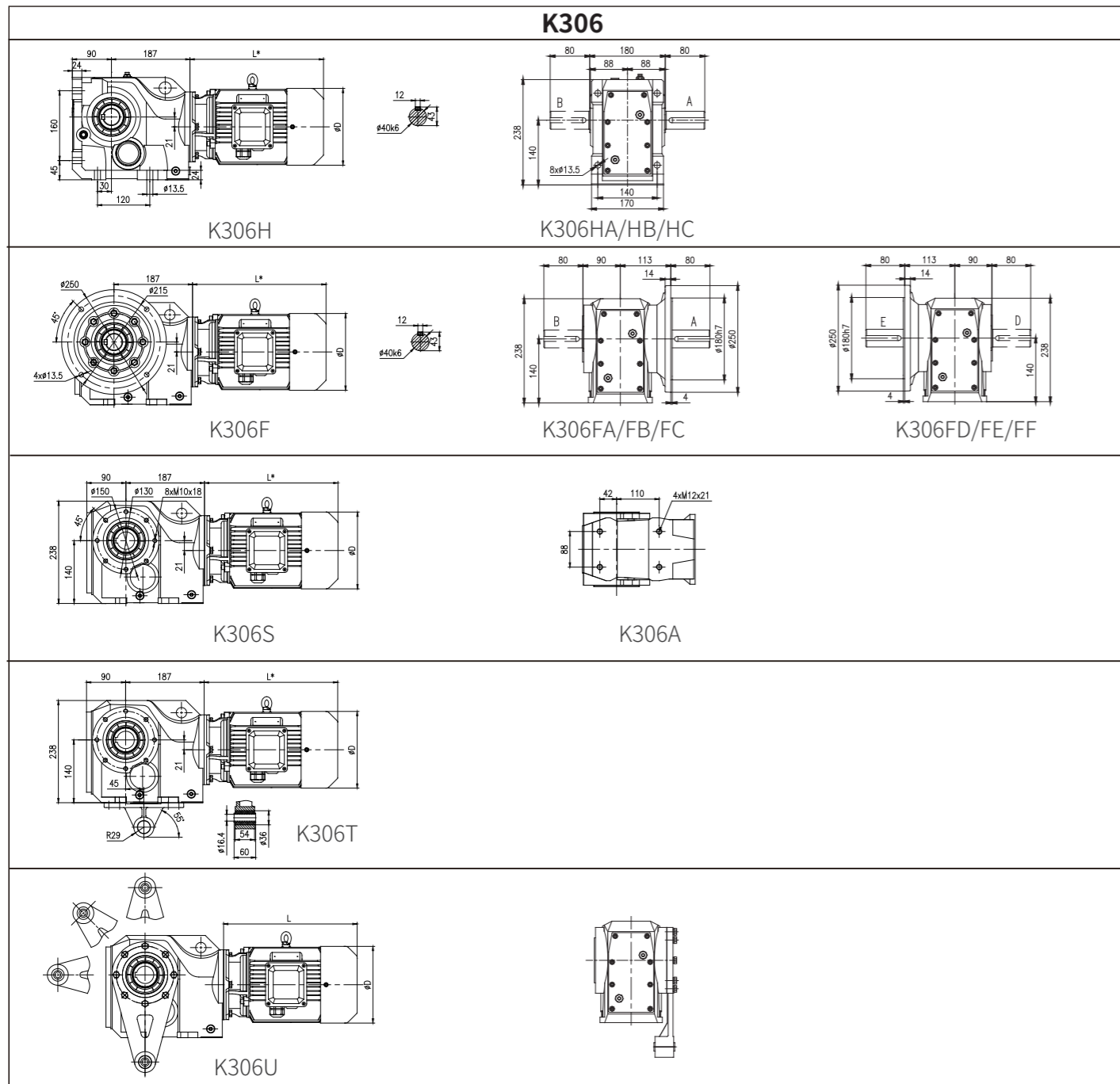

MP motor dimension for K306

MP	P ₁ /kW	i _N	MP							D
			L1	L2	L3	L5	L6	L7		
Fan	0.37	90-125	224	269	264	314	314	354	139	
Driven fan	0.55	63-125	300	345	360	405	405	455	162	
Brake + fan	0.75	45-125	300	345	360	405	405	455	162	
Double brake	1.1	31.5-90	323	368	378	423	423	478	176	
Brake + Driven fan	1.5	22.4-90	348	393	403	448	448	503	176	
Encorder + Driven fan	2.2	14-80	395	435	470	510	510	565	202	
Brake + Encorder + Driven fan	3	9-56	395	435	470	510	510	565	202	
	4	7.1-40	459	509	534	584	584	639	220	
	5.5	4-31.5	470	520	550	595	595	650	259	
	7.5	4-22.4	508	558	588	633	633	688	259	

注:渐开线花键空心轴的花键规格DIN5480: Note: Involute spline size DIN5480: m2×z16×α30×D35×9H

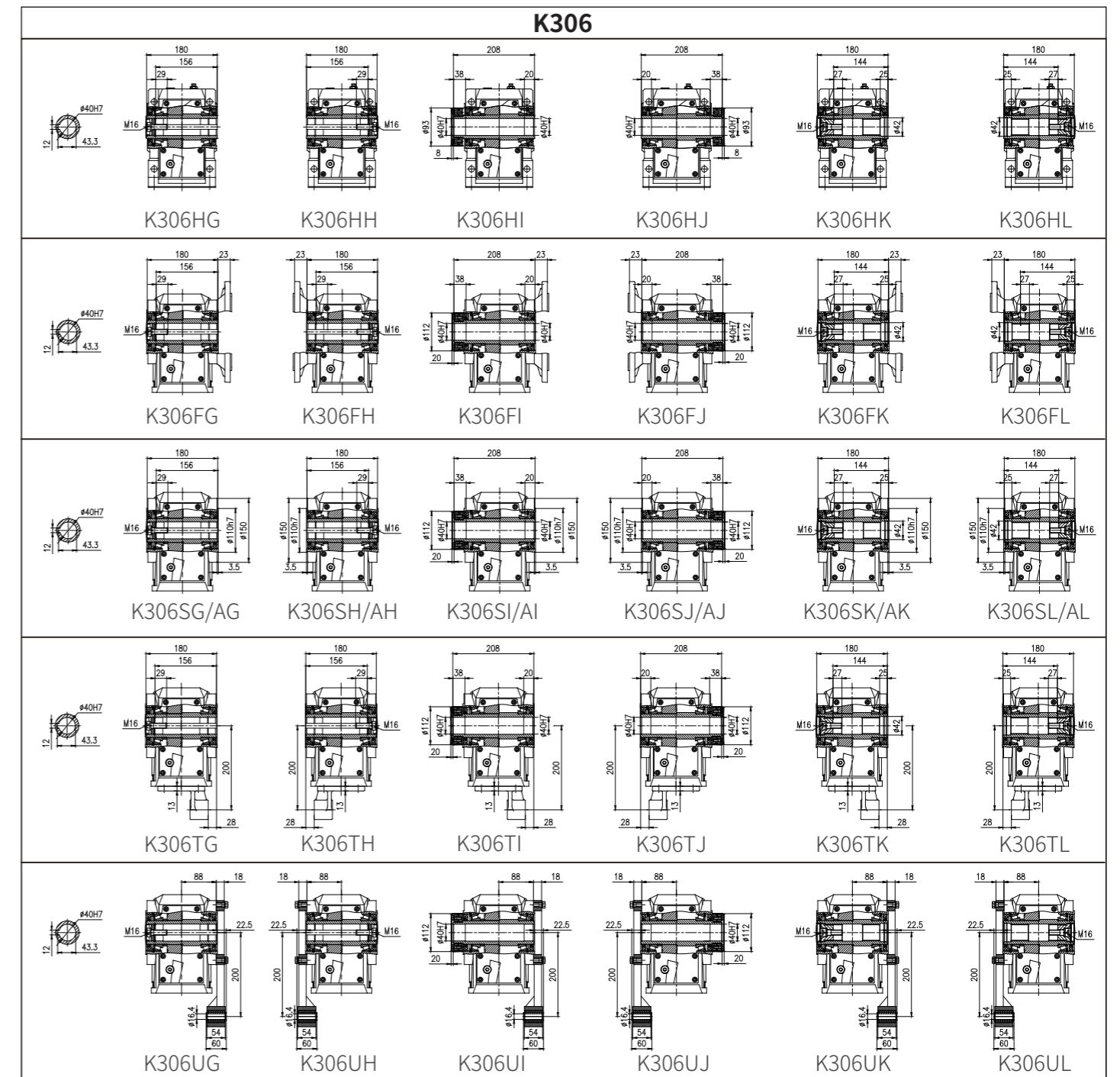

K306/C.03

MP motor dimension for K306/C.03

MP	P ₁ /kW	i _N	MP							D
			L1	L2	L3	L5	L6	L7		
K306/C203	0.12	112-2240	206	/	241	/	/	/	124	
K306/C303	0.18	112-1250	206	/	241	/	/	/	124	
	0.25	112-1000	228	/	263	/	/	/	139	
	0.37	112-710	228	/	263	/	/	/	139	
	0.55	112-450	299	344	359	404	404	454	162	
	0.75	112-315	299	344	359	404	404	454	162	
	1.1	112-224	322	367	377	422	422	477	176	
	1.5	112-160	347	392	402	447	447	502	176	
	2.2	112	394	434	469	509	509	564	202	

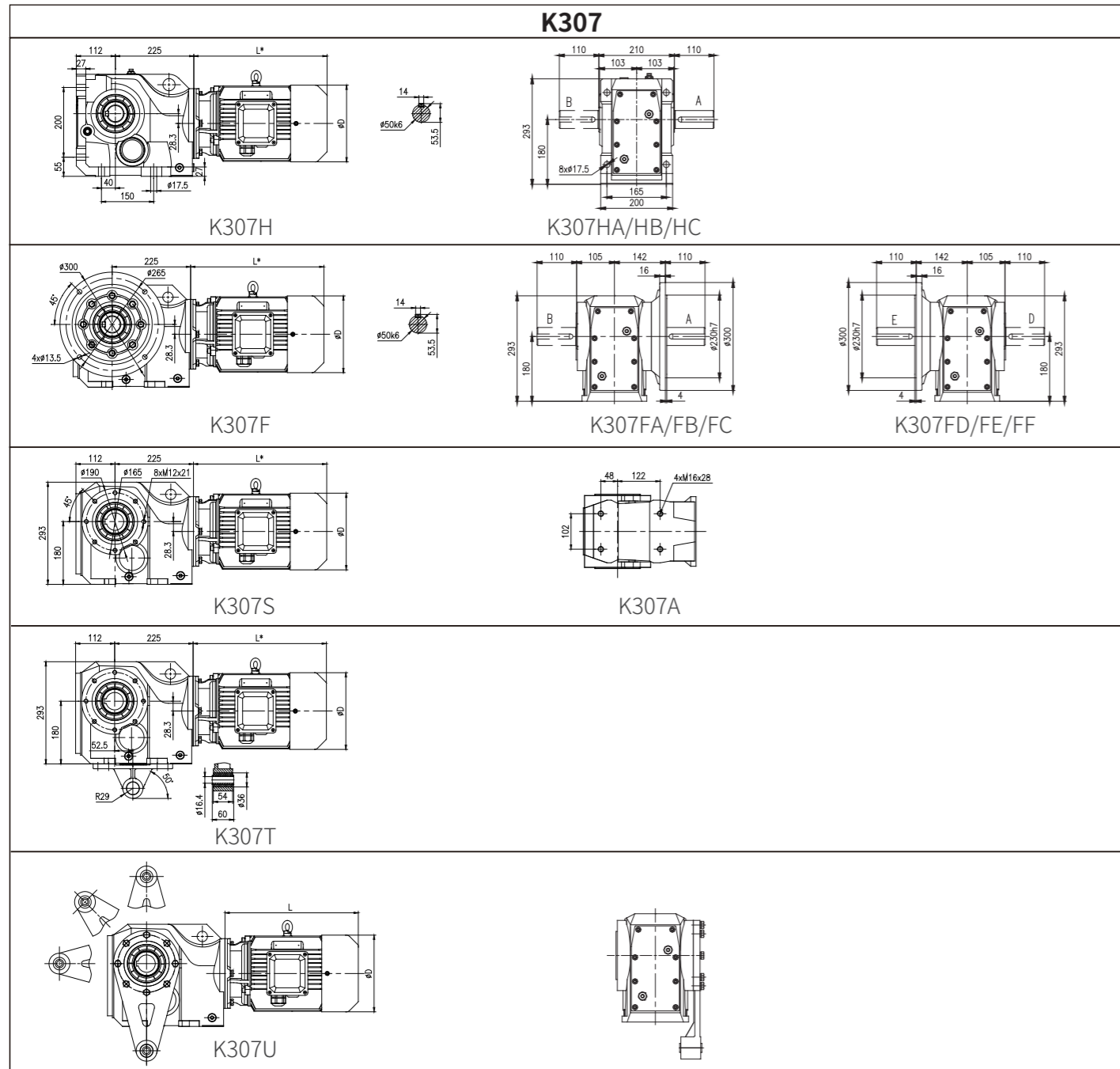

MP motor dimension for K307

P ₁ /kW	i _N	MP							D
		L1	L2	L3	L5	L6	L7		
0.37	160-180	216	261	256	306	306	346	139	
0.55	112-180	292	337	352	397	397	447	162	
0.75	90-180	292	337	352	397	397	447	162	
1.1	56-112	315	360	370	415	415	470	176	
1.5	40-112	340	385	395	440	440	495	176	
2.2	28-112	387	427	462	502	502	557	202	
3	20-112	387	427	462	502	502	557	202	
4	16-80	451	501	526	576	576	631	220	
5.5	9-50	459	509	539	584	584	639	259	
7.5	7.1-40	497	547	577	622	622	677	259	
11	7.1-28	551	586	646	676	676	726	314	
15	7.1-20	581	616	676	706	706	756	314	

注: 渐开线花键空心轴的花键规格DIN5480: Note: Involute spline size DIN5480: m2×z24×α30×D50×9H

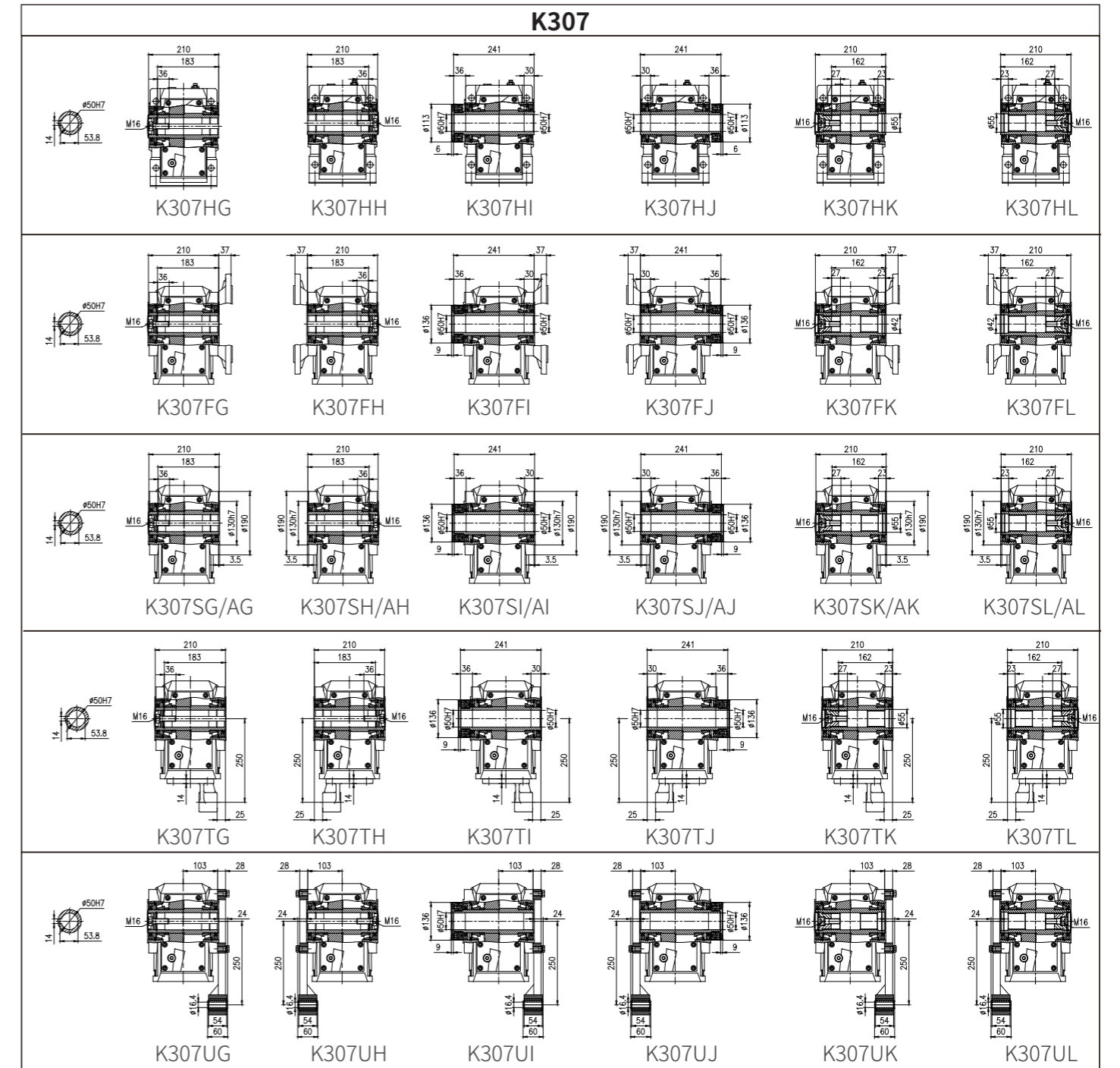

K307/C.03

MP motor dimension for K307/C.03

P ₁ /kW	i _N	MP							D
		L1	L2	L3	L5	L6	L7		
0.12	112-4000	206	261	241	296	/	/	124	
0.18	112-2500	206	261	241	296	/	/	124	
0.25	112-1800	223	268	263	313	313	353	139	
0.37	112-1250	223	268	263	313	313	353	139	
0.55	112-800	299	344	359	404	404	454	162	
0.75	112-630	299	344	359	404	404	454	162	
1.1	112-355	322	367	377	422	422	477	176	
1.5	112-280	347	392	402	447	447	502	176	
2.2	112-200	394	434	469	509	509	564	202	
3	112-140	394	434	469	509	509	564	202	

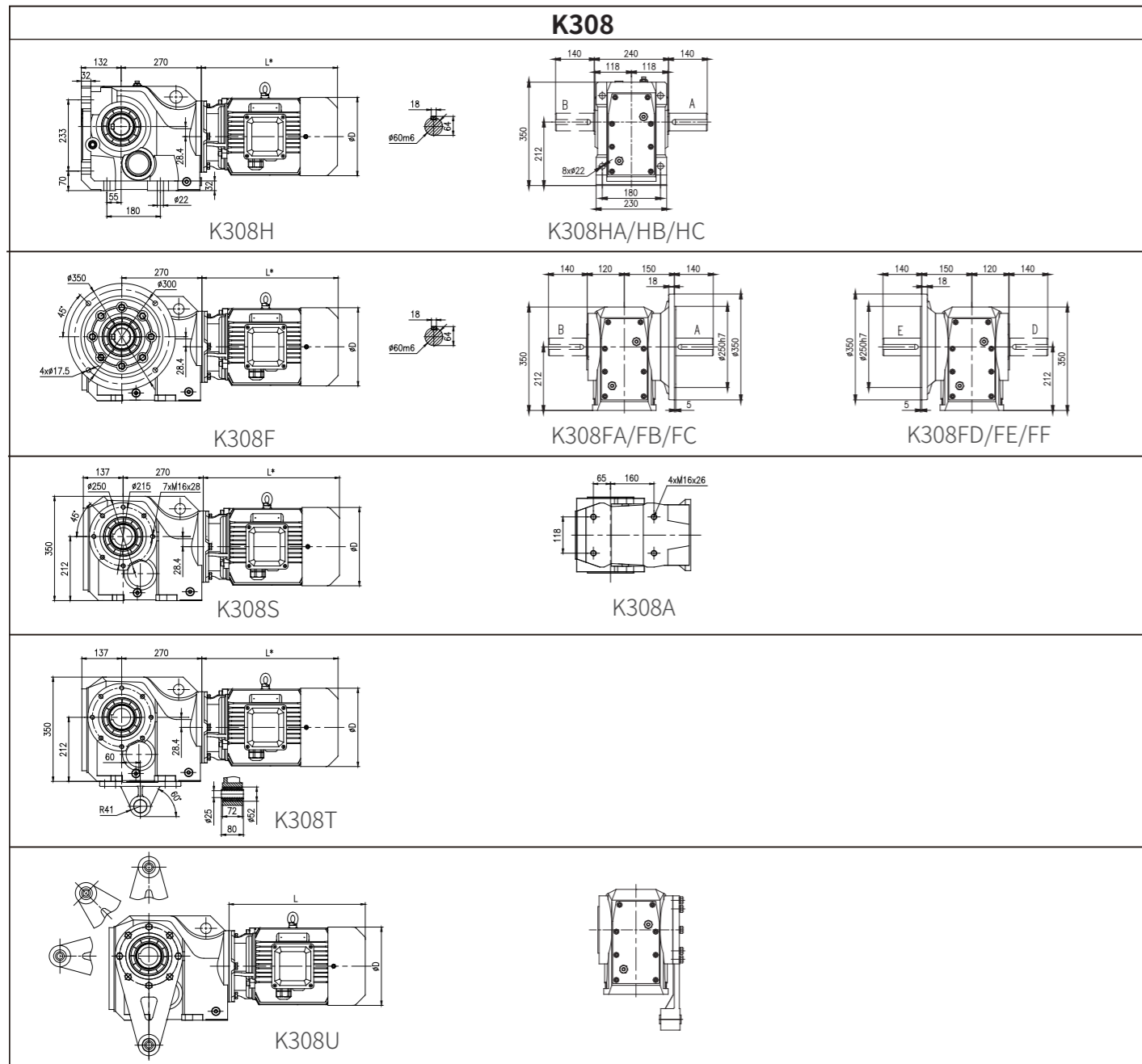

MP motor dimension for K308

	P _i /kW	i _N	MP							D
			L1	L2	L3	L5	L6	L7		
	0.55	160-180	283	328	343	388	388	438	162	
	0.75	140-180	283	328	343	388	388	438	162	
	1.1	100-160	306	351	361	406	406	461	176	
	1.5	71-160	331	376	386	431	431	486	176	
	2.2	50-160	378	418	453	493	493	548	202	
	3	35.5-160	378	418	453	493	493	548	202	
	4	25-140	442	492	517	567	567	622	220	
	5.5	16-80	451	501	531	576	576	631	259	
	7.5	8-71	489	539	569	614	614	669	259	
	11	7.1-50	550	585	645	675	675	725	314	
	15	7.1-35.5	580	615	675	705	705	755	314	
	18.5	7.1-28	621	651	731	756	756	801	356	
	22	7.1-25	669	699	779	804	804	849	356	

注:渐开线花键空心轴的花键规格DIN5480: Note: Involute spline size DIN5480:
m2×z31×α30×D65×9H m2×z31×α30×D65×9H

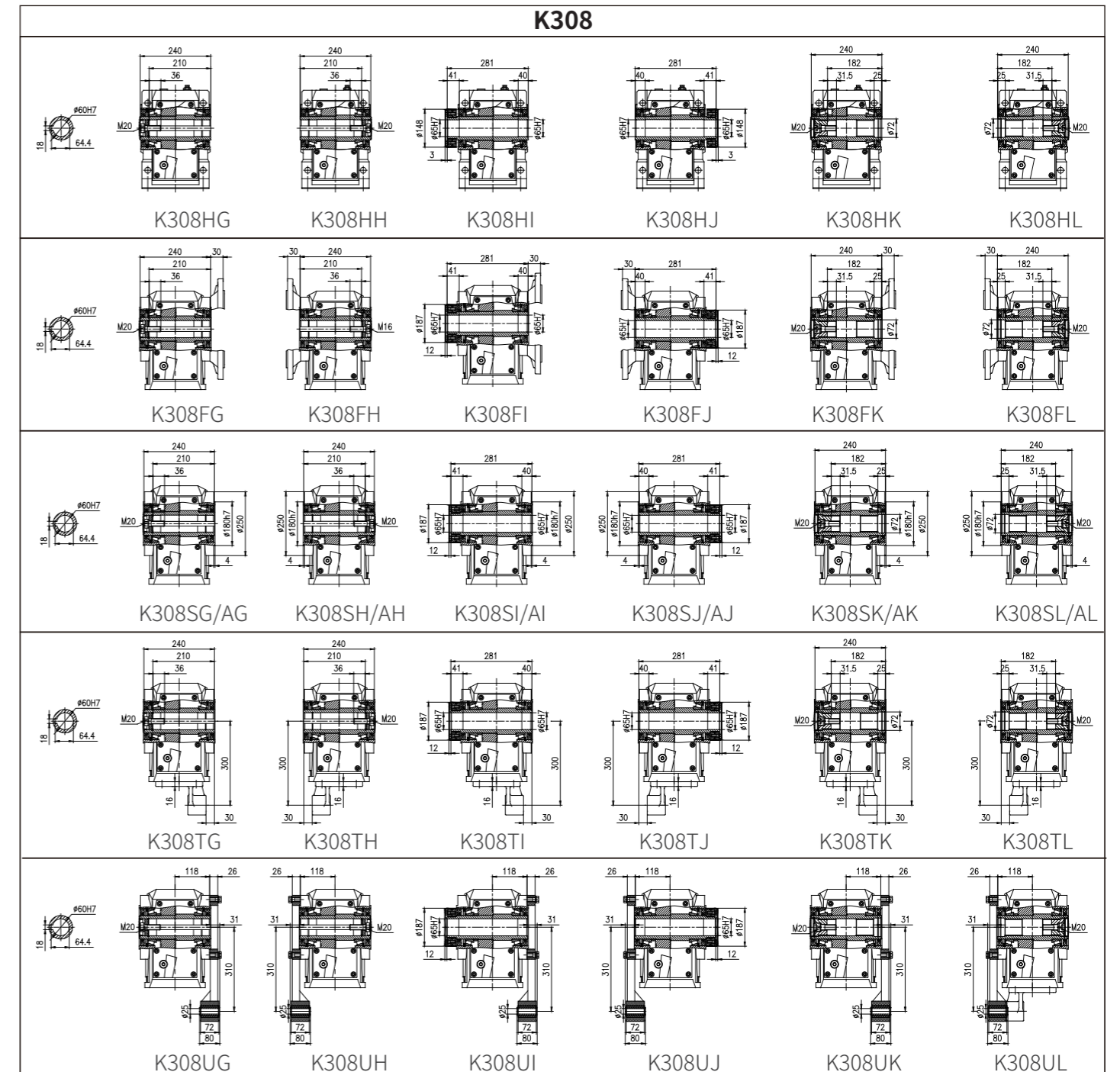

K308/C.05

MP motor dimension for K308/C.05

	P _i /kW	i _N	MP							D
			L1	L2	L3	L5	L6	L7		
	0.12	112-6300	206	261	241	296	/	/	124	
	0.18	112-4000	206	261	241	296	/	/	124	
	0.25	112-3150	223	268	263	313	313	353	139	
	0.37	112-2000	223	268	263	313	313	353	139	
	0.55	112-1250	299	344	359	404	404	454	162	
	0.75	112-1000	299	344	359	404	404	454	162	
	1.1	112-355	322	367	377	422	422	477	176	
	1.5	112-355	347	392	402	447	447	502	176	
	2.2	112-355	394	434	469	509	509	564	202	
	3	112-250	394	434	469	509	509	564	202	

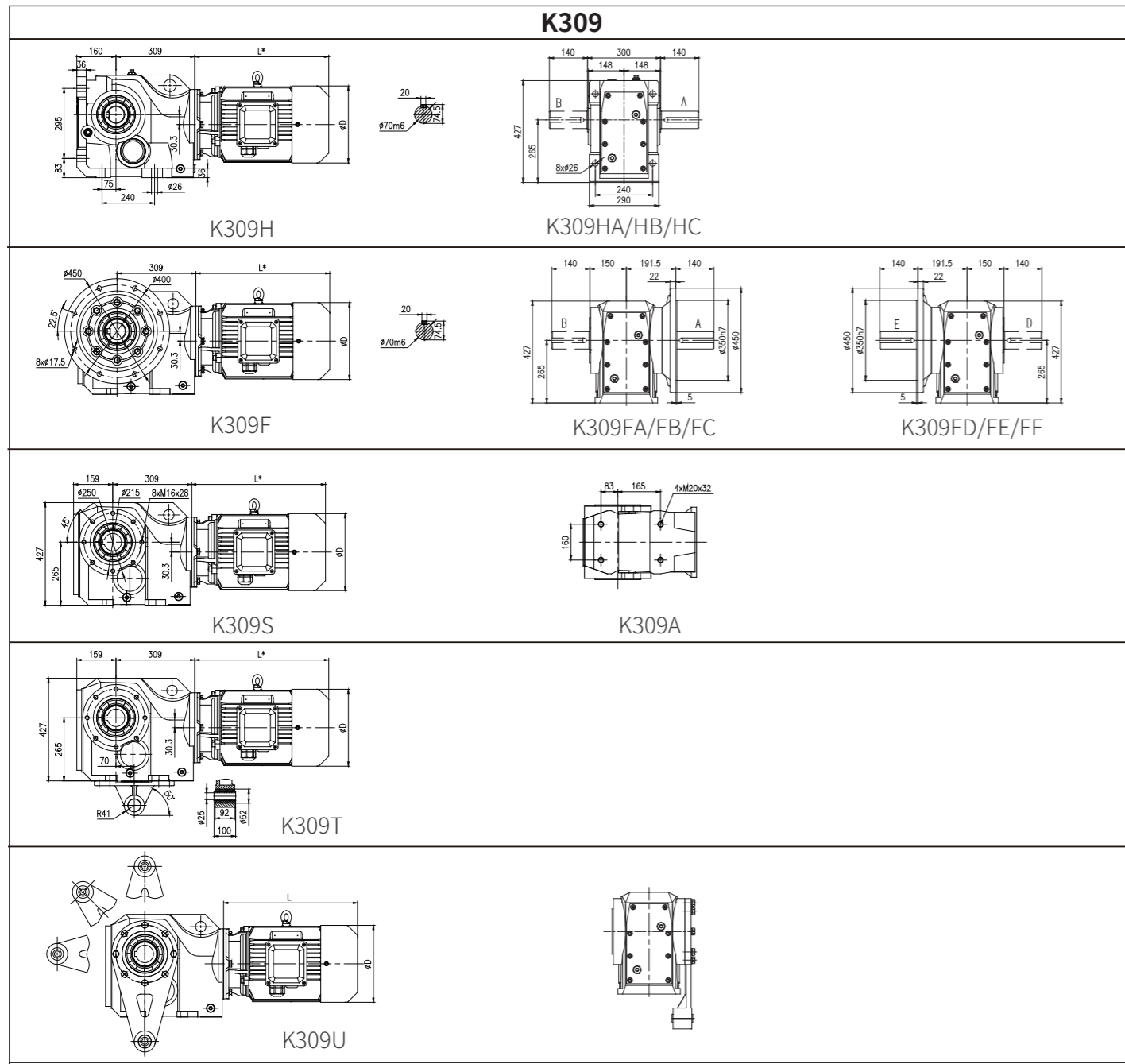

MP motor dimension for K309

P ₁ /kW	i _N	MP							D
		L1	L2	L3	L5	L6	L7		
1.1	140-180	303	348	358	403	403	458	176	
1.5	112-180	328	373	383	428	428	483	176	
2.2	90-180	374	414	449	489	489	544	202	
3	63-180	374	414	449	489	489	544	202	
4	45-180	438	488	513	563	563	618	220	
5.5	35.5-112	450	500	530	575	575	630	259	
7.5	25-112	488	538	568	613	613	668	259	
11	16-90	544	579	639	669	669	719	314	
15	9-63	574	609	669	699	699	749	314	
18.5	7.1-50	615	645	725	750	750	795	356	
22	7.1-40	663	693	773	798	798	843	356	
30	7.1-28	705	710	820	825	825	870	398	

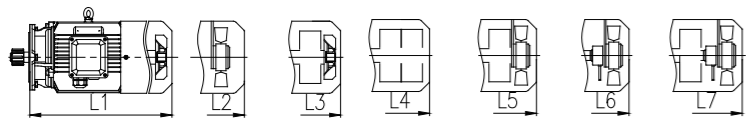

注:渐开线花键空心轴的花键规格DIN5480: Note: Involute spline size DIN5480: m2×z34×a30×D70×9H

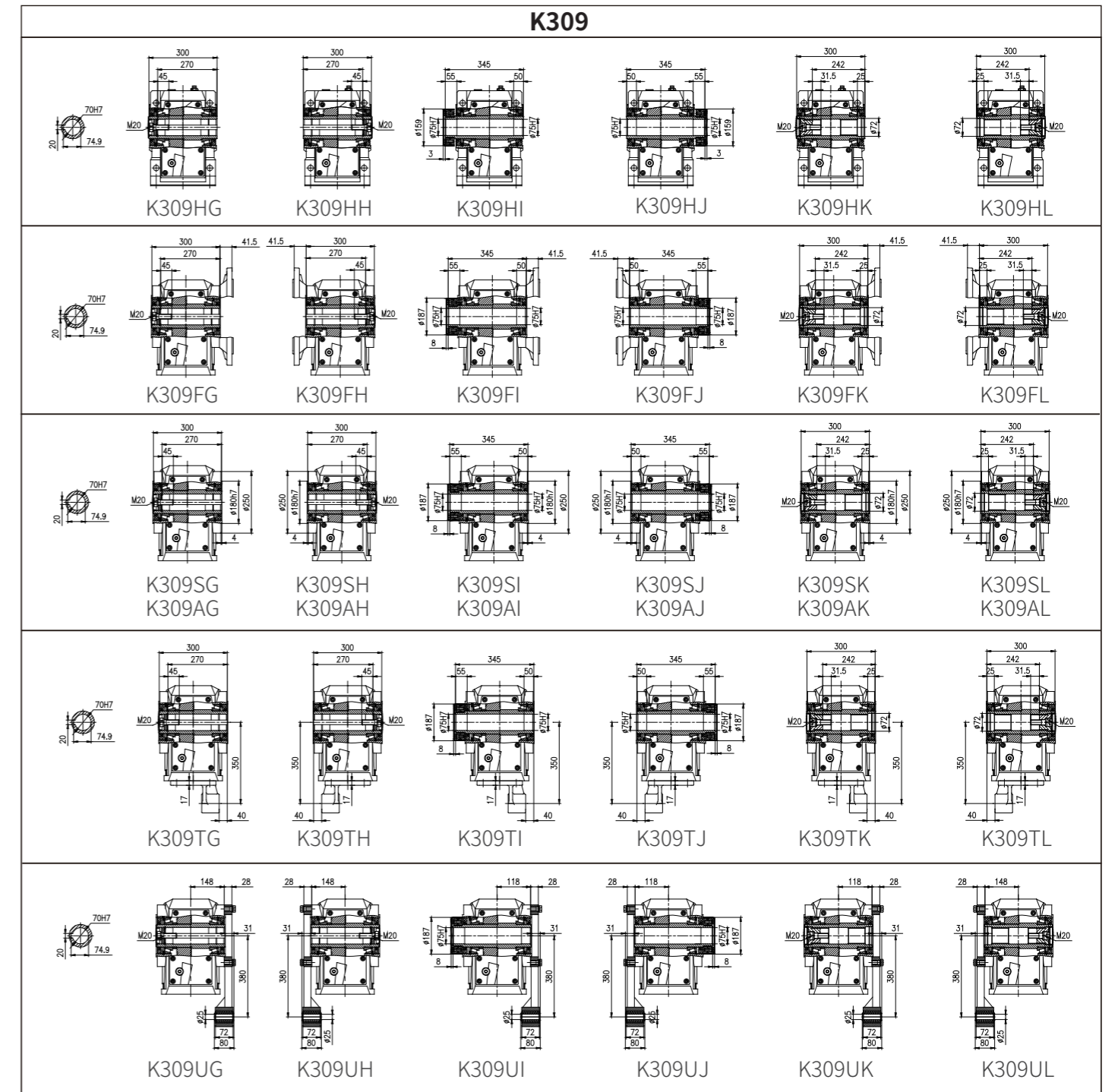

K309/C.05

MP motor dimension for K309/C.05

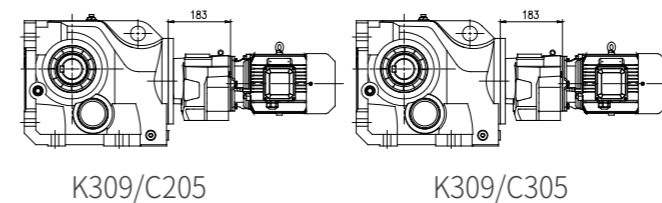

P ₁ /kW	i _N	MP							D
		L1	L2	L3	L5	L6	L7		
0.12	112-11200	207	262	242	297	/	/	124	
0.18	112-7100	207	262	242	297	/	/	124	
0.25	112-5000	224	269	264	314	314	354	139	
0.37	112-3550	224	269	264	314	314	354	139	
0.55	112-2240	300	345	360	405	405	455	162	
0.75	112-1600	300	345	360	405	405	455	162	
1.1	112-1250	323	368	378	423	423	478	176	
1.5	112-900	348	393	403	448	448	503	176	
2.2	112-630	395	435	470	510	510	565	202	
3	112-400	395	435	470	510	510	565	202	
4	112-315	459	509	534	584	584	639	220	

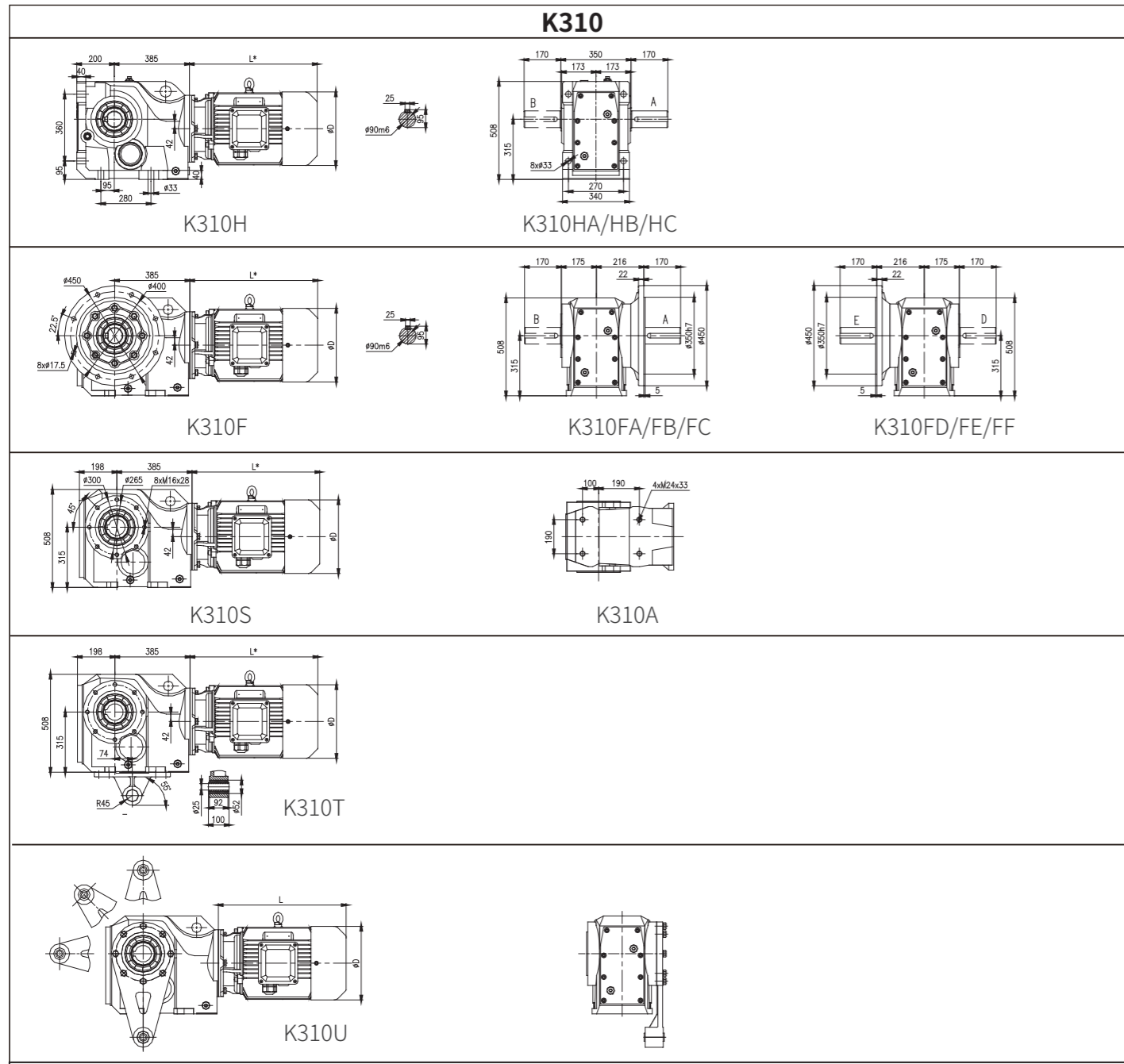

MP motor dimension for K310

MP	P ₁ /kW	i _N	MP							D
			L1	L2	L3	L5	L6	L7		
	2.2	140-180	370	410	445	485	485	540	202	
	3	112-180	370	410	445	485	485	540	202	
	4	80-180	434	484	509	559	559	614	220	
	5.5	56-125	439	489	519	564	564	619	259	
	7.5	40-125	477	527	557	602	602	657	259	
	11	28-125	533	568	628	658	658	708	314	
	15	20-112	563	598	658	688	688	738	314	
	18.5	16-90	604	634	714	739	739	784	356	
	22	12.5-80	652	682	762	787	787	832	356	
	30	8-50	705	710	820	825	825	870	398	
	37	8-40	746	776	861	891	891	936	446	
	45	8-35.5	746	776	861	891	891	936	446	

注: 渐开线花键空心轴的花键规格DIN5480: Note: Involute spline size DIN5480: m3×z27×α30×D85×9H

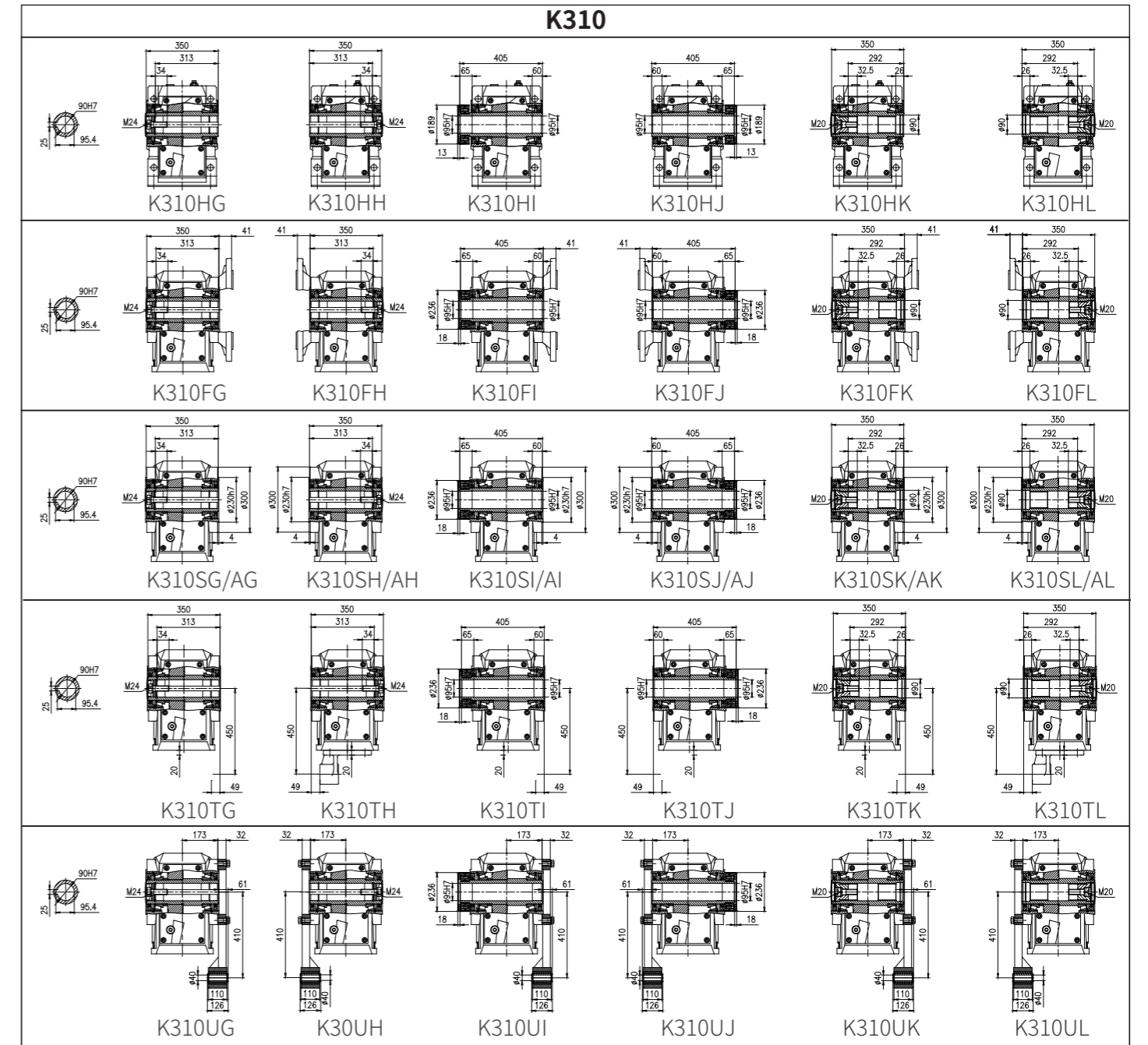

K310/C.07

MP motor dimension for K310/C.07

MP	P ₁ /kW	i _N	MP							D
			L1	L2	L3	L5	L6	L7		
	0.12	112-14000	207	262	242	297	/	/	124	
	0.18	112-12500	207	262	242	297	/	/	124	
	0.25	112-9000	224	269	264	314	314	354	139	
	0.37	112-5600	224	269	264	314	314	354	139	
	0.55	112-4000	300	345	360	405	405	455	162	
	0.75	112-2800	300	345	360	405	405	455	162	
	1.1	112-1800	323	368	378	423	423	478	176	
	1.5	112-1400	348	393	403	448	448	503	176	
	2.2	112-1000	395	435	470	510	510	565	202	
	3	112-710	395	435	470	510	510	565	202	
	4	112-560	459	509	534	584	584	639	220	
	5.5	112-250	459	509	539	584	584	639	259	
	7.5	112-250	497	547	577	622	622	677	259	
	11	112-200	551	586	646	676	676	726	314	
	15	112-140	581	616	676	706	706	756	314	

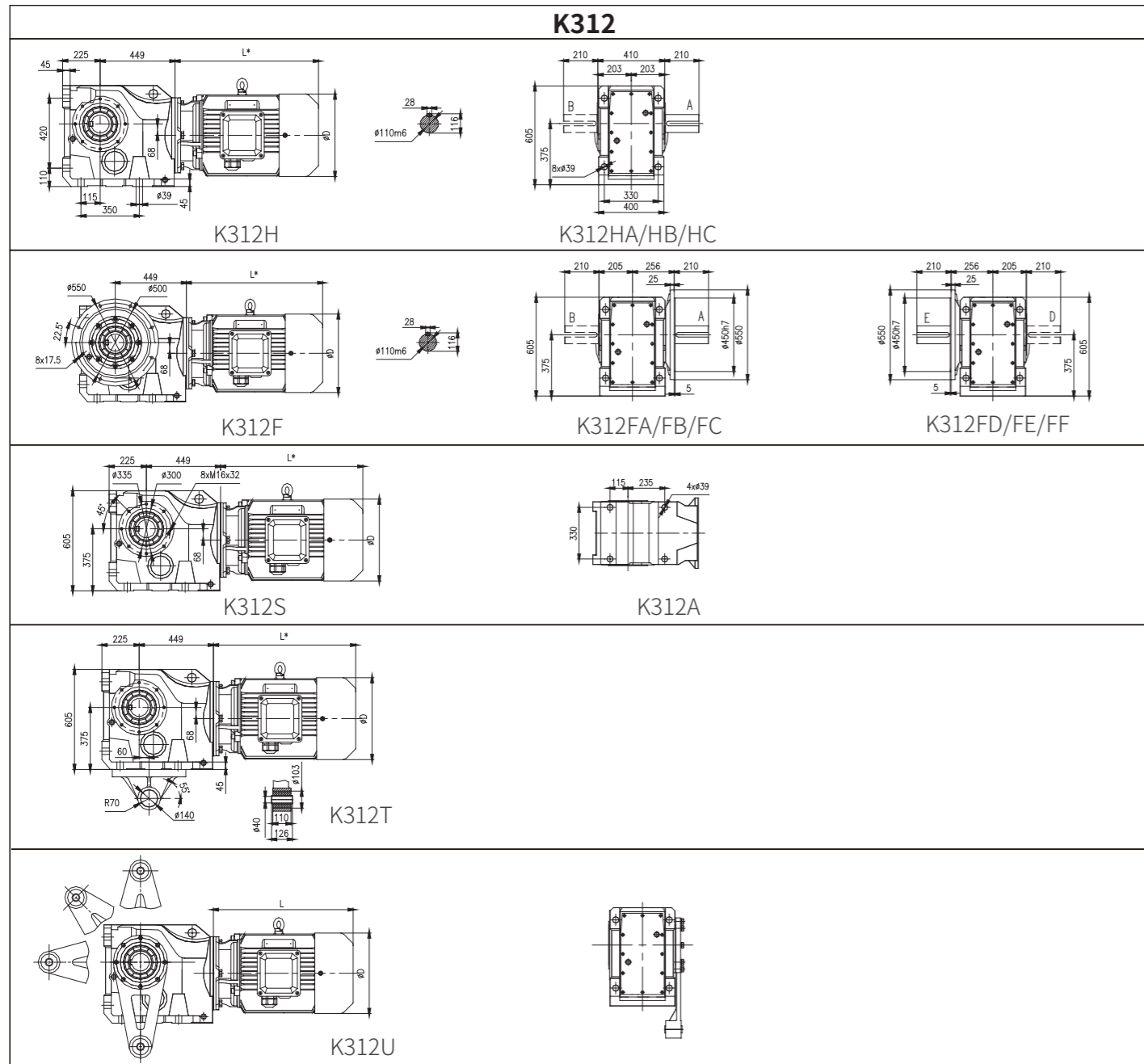

MP motor dimension for K312

MP	P ₁ /kW	i _N	MP							D
			L1	L2	L3	L5	L6	L7		
Fan	4	140-180	423	473	498	548	548	603	220	
Driven fan	5.5	100-140	429	479	509	554	554	609	259	
Brake + fan	7.5	71-140	467	517	547	592	592	647	259	
Double brake	11	45-140	517	552	612	642	642	692	314	
Brake + Driven fan	15	35.5-140	547	582	642	672	672	722	314	
Encorder + Driven fan	18.5	28-140	588	618	698	723	723	768	356	
Brake + Encorder + Driven fan	22	25-112	636	666	746	771	771	816	356	
	30	16-90	684	689	799	804	804	849	398	
	37	9-71	725	755	840	870	870	915	446	
	45	7.1-56	725	755	840	870	870	915	446	
	55	7.1-45	841	856	981	991	991	1036	485	
	75	7.1-35.5	886	916	1026	1061	1061	1106	547	
	90	7.1-28	937	967	1077	1112	1112	1157	547	

注:渐开线花键空心轴的花键规格DIN5480: Note: Involute spline size DIN5480: m3×z30×α30×D95×9H

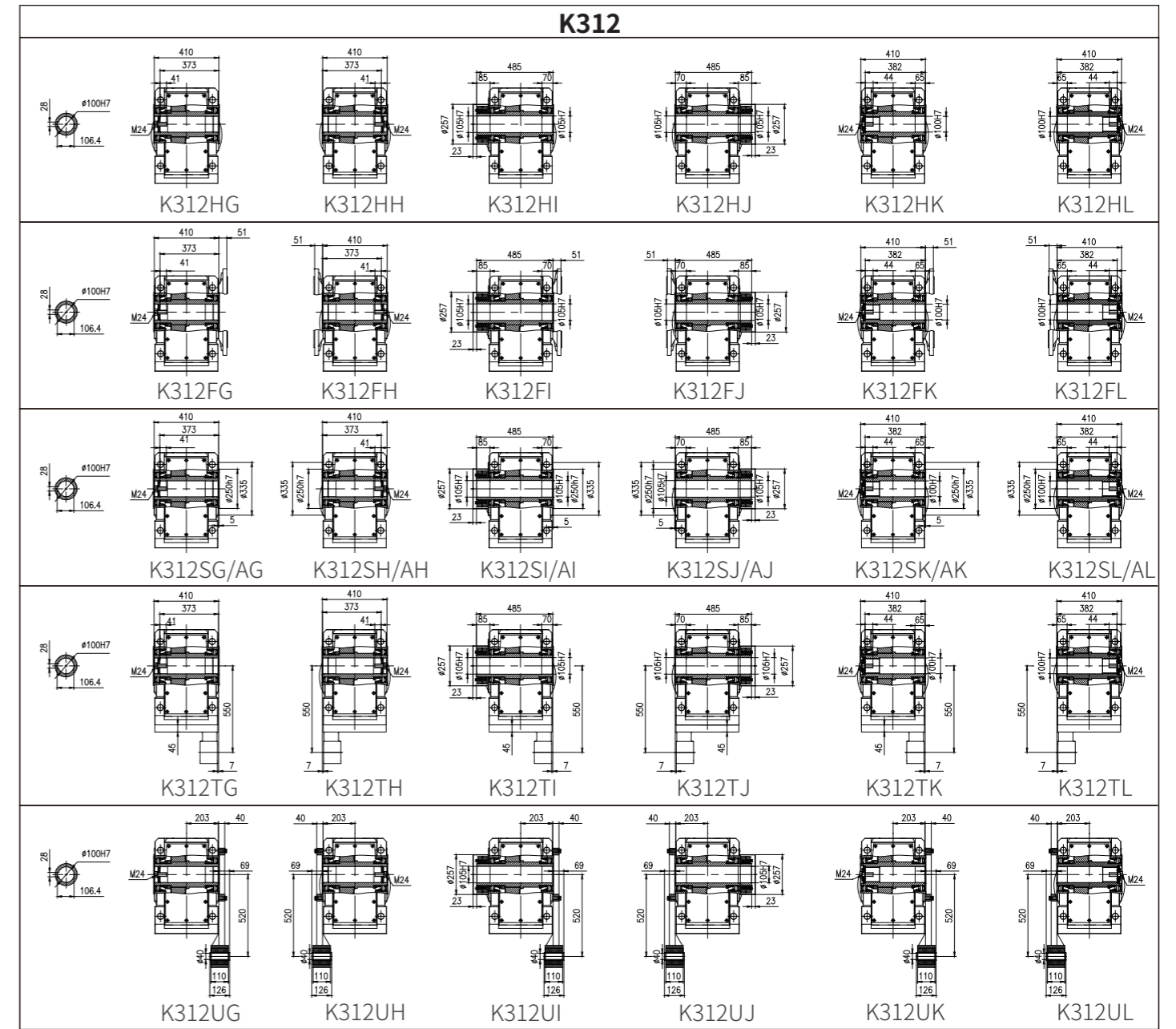

K312/C...

MP motor dimension for K312/C...

P ₁ /kW	i _N	MP							D
		L1	L2	L3	L5	L6	L7		
0.12	800-14000	199	254	234	289	/	/	124	
0.18	800-14000	199	254	234	289	/	/	124	
0.25	800-14000	216	261	256	306	306	346	139	
0.37	800-9000	216	261	256	306	306	346	139	
0.55	450-7100	292	337	352	397	397	447	162	
0.75	450-5000	292	337	352	397	397	447	162	
1.1	112-3150	315	360	370	415	415	470	176	
1.5	112-2240	340	385	395	440	440	495	176	
2.2	112-1600	387	427	462	502	502	557	202	
3	112-1120	387	427	462	502	502	557	202	
4	112-900	451	501	526	576	576	631	220	
5.5	112-400	451	501	531	576	576	631	259	
7.5	112-400	489	539	569	614	614	669	259	
11	112-315	550	585	645	675	675	725	314	
15	112-250	580	615	675	705	705	755	314	
18.5	112-200	621	651	731	756	756	801	356	
22	112-160	669	699	779	804	804	849	356	

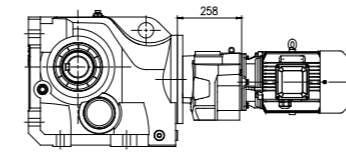

K312/C208

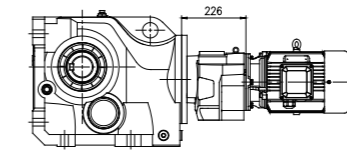

K312/C307

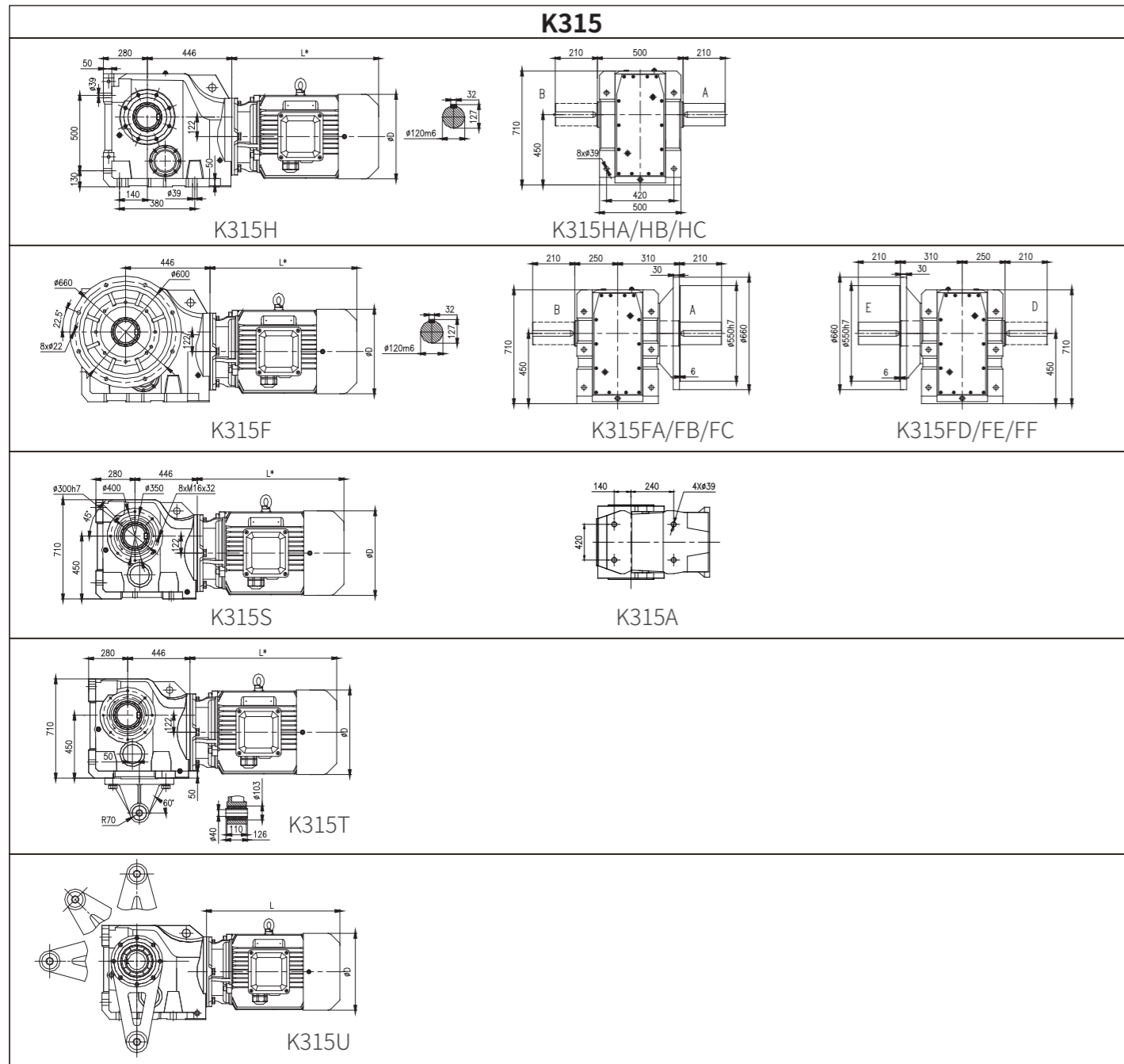

MP motor dimension for K315

MP	P ₁ /kW	i _N	MP							D
			L1	L2	L3	L5	L6	L7		
Fan	7.5	100-140	467	517	547	592	647	647	259	
Driven fan	11	71-140	502	537	597	627	677	677	314	
Brake + fan	15	50-140	532	567	627	657	707	707	314	
Double brake	18.5	40-140	573	603	683	708	753	753	356	
Brake + Driven fan	22	31.5-140	621	651	731	756	801	801	356	
Encorder + Driven fan	30	25-112	674	679	789	794	839	839	398	
Brake + Encorder + Driven fan	37	20-100	715	745	830	860	905	905	446	
	45	16-80	715	745	830	860	905	905	446	
	55	12.5-71	831	846	971	981	1026	1026	485	
	75	10-50	876	906	1016	1051	1096	1096	547	
	90	10-40	927	957	1067	1102	1147	1147	547	

注: 渐开线花键空心轴的花键规格DIN5480: Note: Involute spline size DIN5480: m3×z38×α30×D120×9H

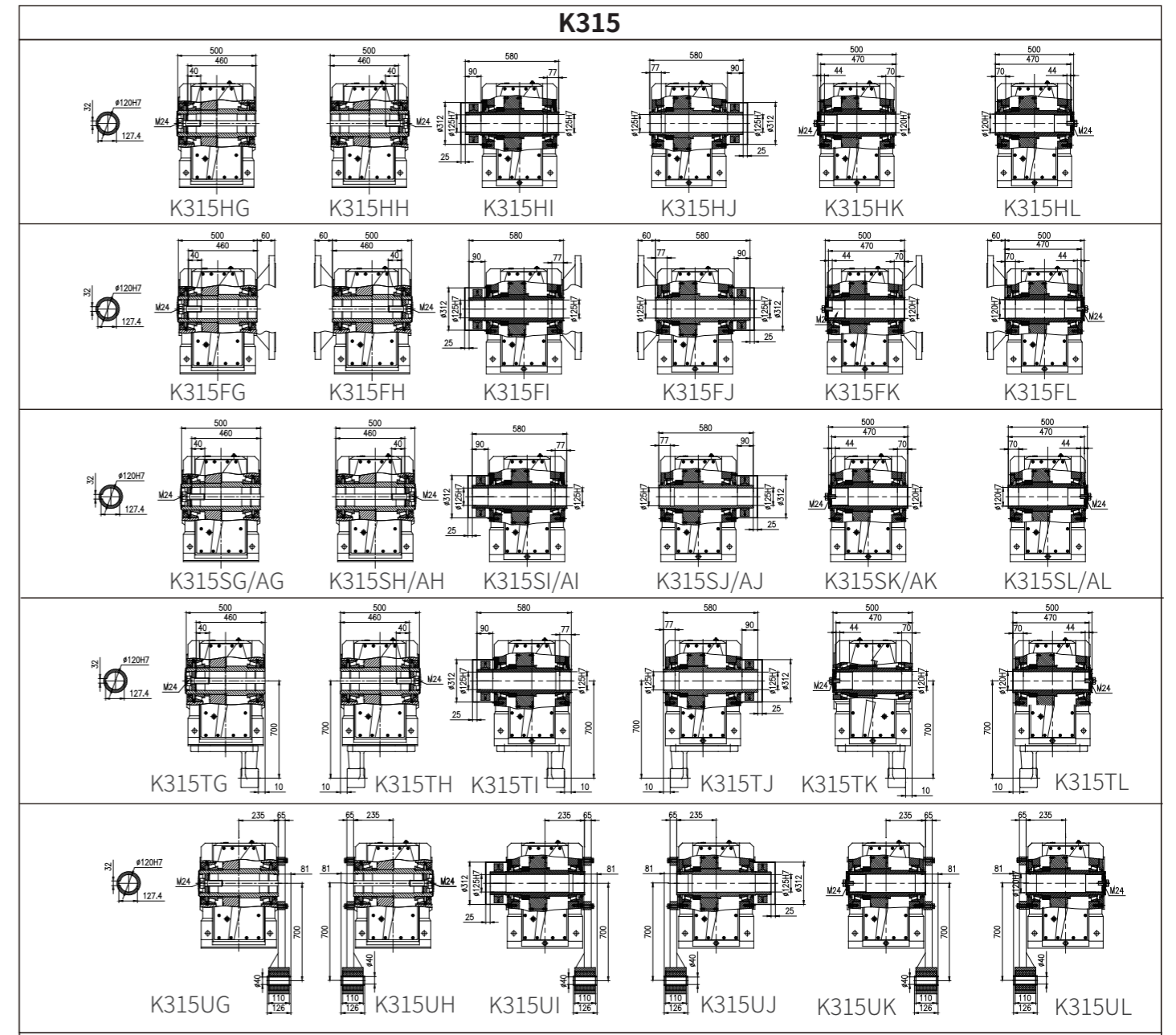

K315/C...

MP motor dimension for K315/C...

P ₁ /kW	i _N	MP							D
		L1	L2	L3	L5	L6	L7		
0.12	800-14000	199	254	234	289	/	/	124	
0.18	800-14000	199	254	234	289	/	/	124	
0.25	800-14000	216	261	256	306	306	346	139	
0.37	800-14000	216	261	256	306	306	346	139	
0.55	450-900	292	337	352	397	397	447	162	
0.75	450-7100	292	337	352	397	397	447	162	
1.1	112-4500	315	360	370	415	415	470	176	
1.5	112-3150	340	385	395	440	440	495	176	
2.2	112-2240	387	427	462	502	502	557	202	
3	112-1800	387	427	462	502	502	557	202	
4	112-1250	451	501	526	576	576	631	220	
5.5	112-400	451	501	531	576	576	631	259	
7.5	112-400	489	539	569	614	614	669	259	
11	112-400	550	585	645	675	675	725	314	
15	112-315	580	615	675	705	705	755	314	
18.5	112-280	621	651	731	756	756	801	356	
22	112-224	669	699	779	804	804	849	356	

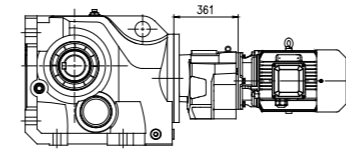

K315/C210

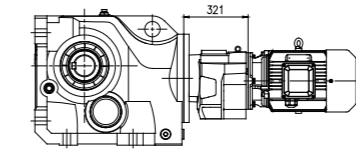

K315/C309

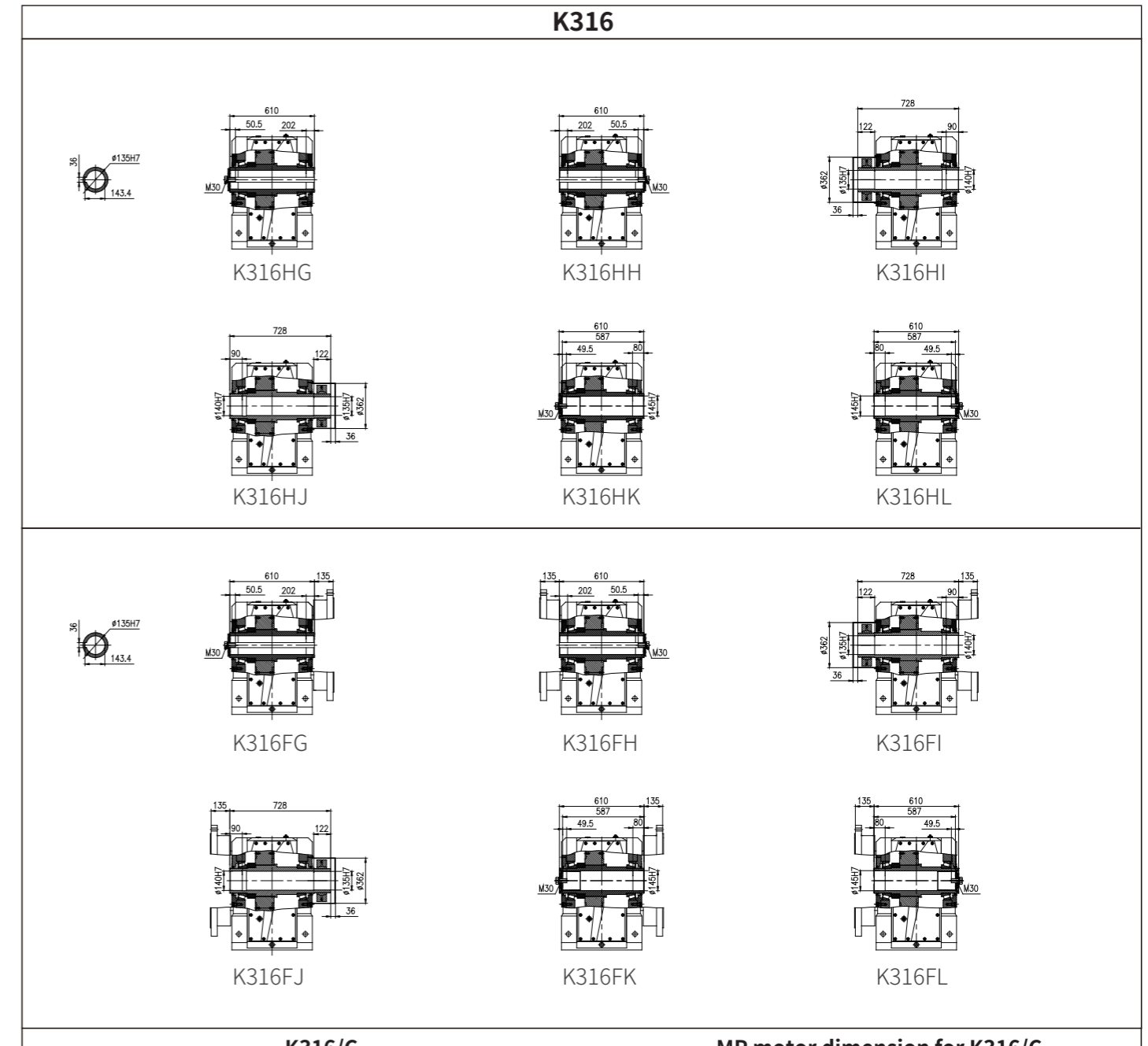
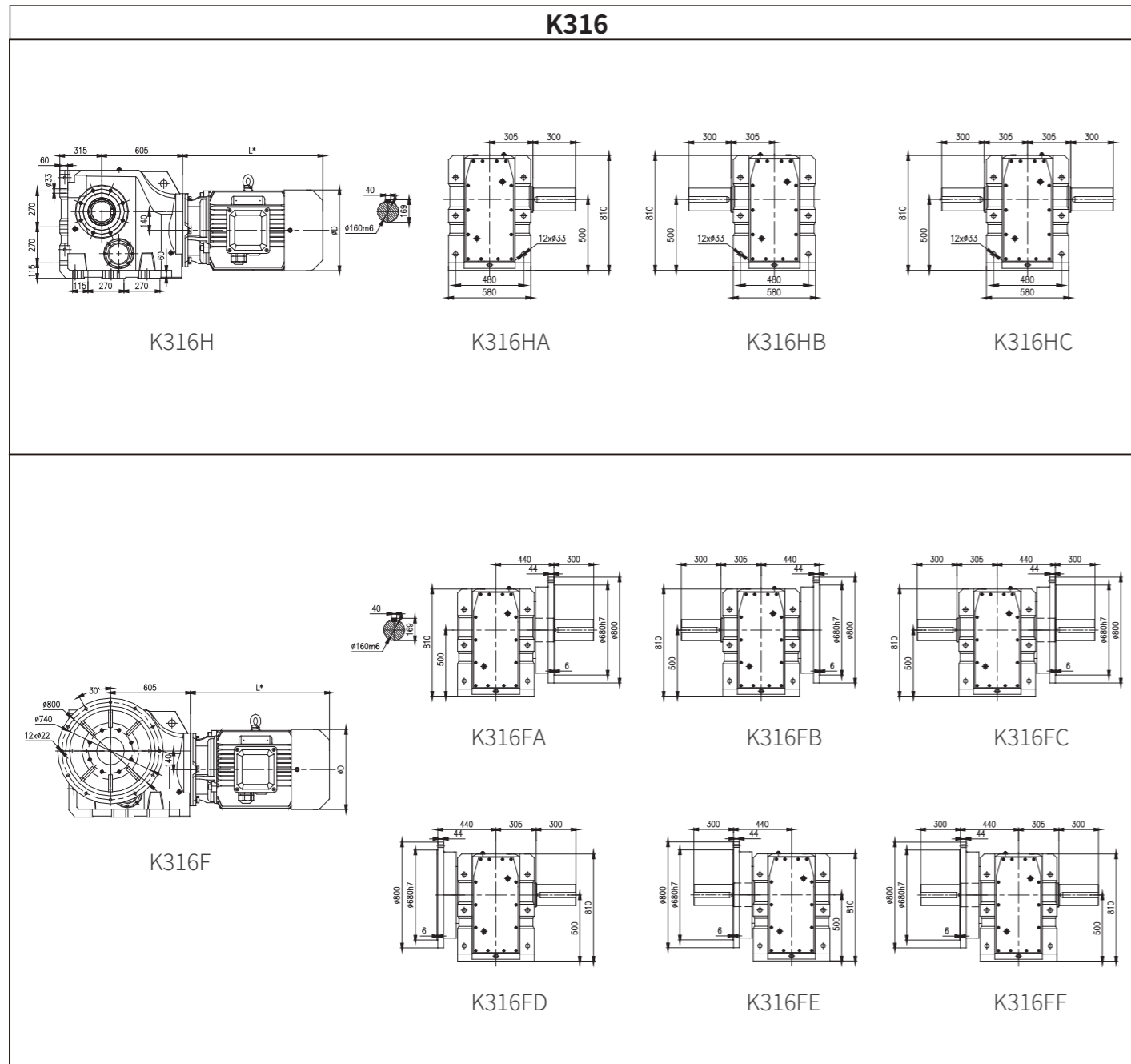

MP motor dimension for K316

MP motor dimension for K316	P ₁ /kW	i _N	MP							D
			L1	L2	L3	L5	L6	L7		
	11	125-160	502	537	597	627	627	677	314	
	15	90-160	532	567	627	657	657	707	314	
	18.5	80-160	573	603	683	708	708	753	356	
	22	63-160	621	651	731	756	756	801	356	
	30	45-112	674	679	789	794	794	839	398	
	37	40-112	715	745	830	860	860	905	446	
	45	31.5-112	715	745	830	860	860	905	446	
	55	25-112	831	846	971	981	981	1026	485	
	75	18-90	876	906	1016	1051	1051	1026	547	
	90	14-80	927	957	1067	1102	1102	1147	547	

注: 渐开线花键空轴的花键规格DIN5480: m3×z45×α30×D140×9H
 Note: Involute spline size DIN5480: m3×z45×α30×D140×9H

K316/C...

MP motor dimension for K316/C...

K316/C...	P ₁ /kW	i _N	MP							D
			L1	L2	L3	L5	L6	L7		
	0.55	1800-14000	283	328	343	388	388	438	162	
	0.75	1800-12500	283	328	343	388	388	438	162	
	1.1	112-9000	306	351	361	406	406	461	176	
	1.5	112-6300	331	376	386	431	431	486	176	
	2.2	112-4500	378	418	453	493	493	548	202	
	3	112-3150	378	418	453	493	493	548	202	
	4	112-2240	442	492	517	567	567	622	220	
	5.5	112-1800	451	501	531	576	576	631	259	
	7.5	112-1250	489	539	569	614	614	669	259	
	11	112-800	550	585	645	675	675	725	314	
	15	112-630	580	615	675	705	705	755	314	
	18.5	112-450	604	634	714	739	739	784	356	
	22	112-450	652	682	762	787	787	832	356	
	30	112-250	705	710	820	825	825	870	398	
	37	112-250	746	776	861	891	891	936	446	
	45	112-224	746	776	861	891	891	936	446	

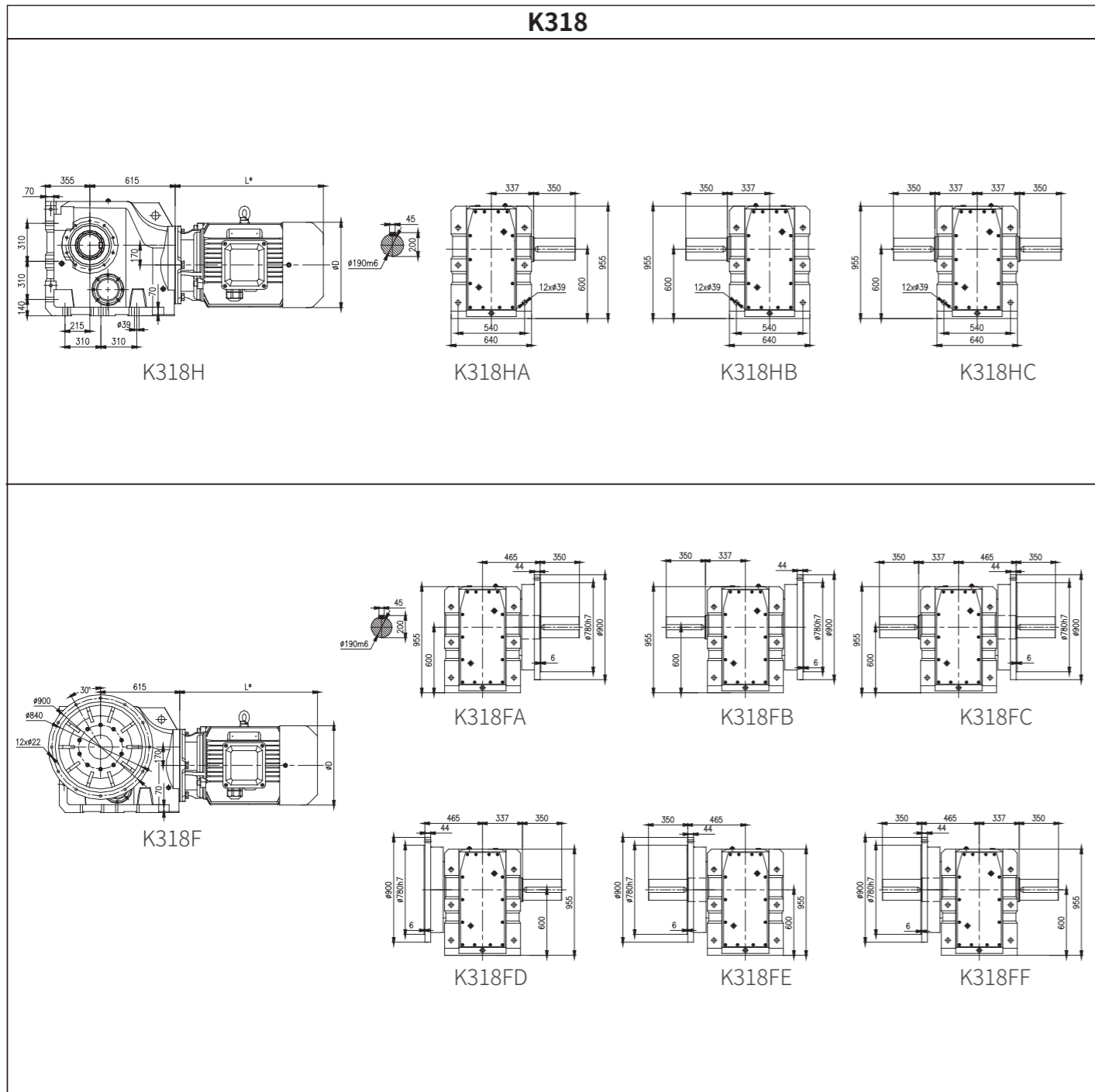

MP motor dimension for K318

MP	P ₁ /kW	i _N	MP							D
			L1	L2	L3	L5	L6	L7		
Fan	15	140-160	532	567	627	657	657	707	314	
Driven fan	18.5	112-160	573	603	683	708	708	753	356	
Brake + fan	22	100-160	621	651	731	756	756	801	356	
Double brake	30	71-140	674	679	789	794	794	839	398	
Brake + Driven fan	37	56-140	715	745	830	860	860	905	446	
Encoder + Driven fan	45	45-140	715	745	830	860	860	905	446	
Brake + Encoder + Driven fan	55	40-140	831	846	971	981	981	1026	485	
	75	28-112	876	906	1016	1051	1051	1096	547	
	90	20-112	927	957	1067	1102	1102	1147	547	

注:渐开线花键空心轴的花键规格DIN5480: Note: Involute spline size DIN5480: m3×z45×α30×D140×9H

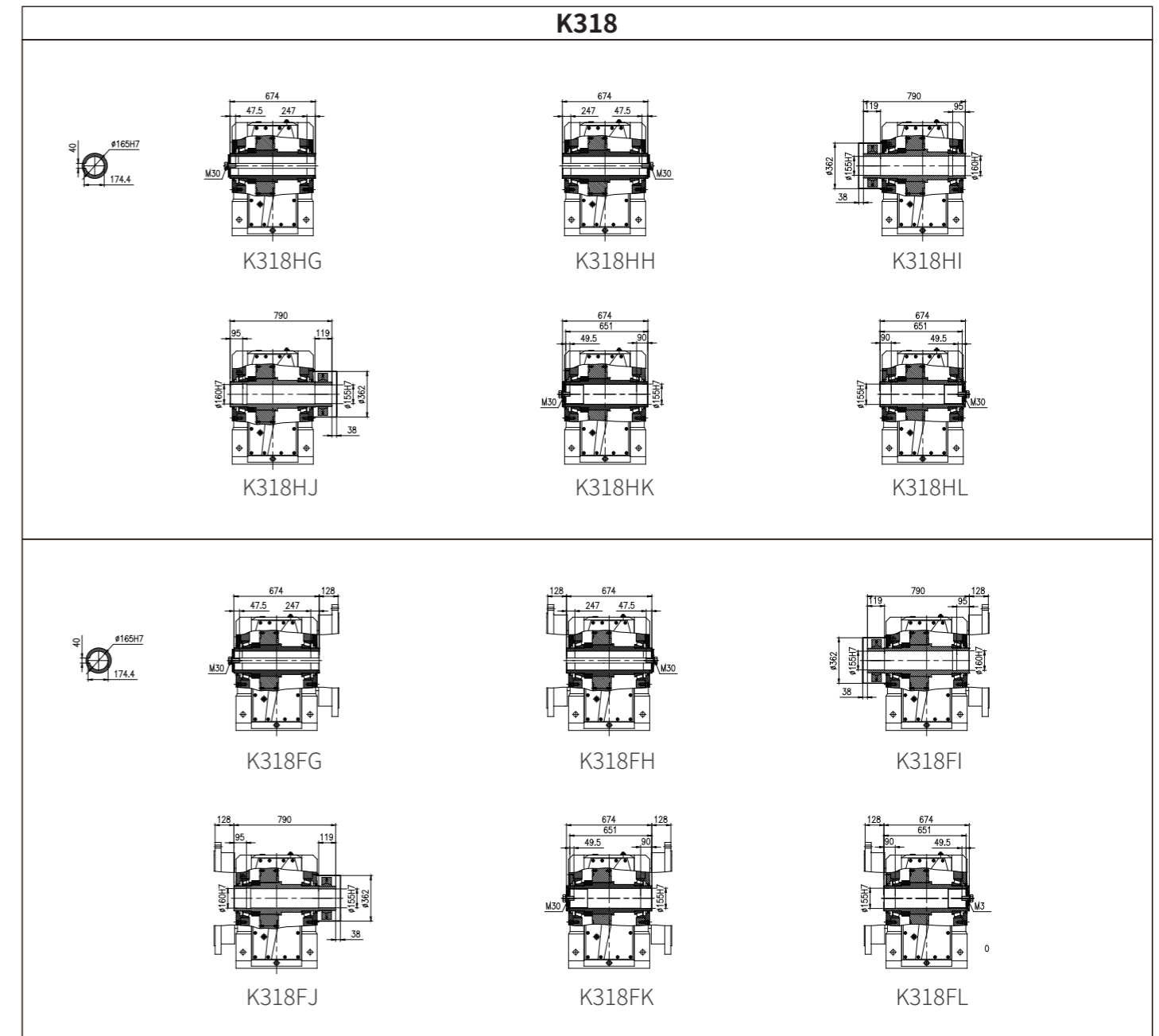

K318/C...

MP motor dimension for K318/C...

MP	P ₁ /kW	i _N	MP							D
			L1	L2	L3	L5	L6	L7		
	0.55	1800-14000	283	328	343	388	388	438	162	
	0.75	1800-14000	283	328	343	388	388	438	162	
	1.1	112-12500	306	351	361	406	406	461	176	
	1.5	112-10000	331	376	386	431	431	486	176	
	2.2	112-6300	378	418	453	493	493	548	202	
	3	112-5000	378	418	453	493	493	548	202	
	4	112-3550	442	492	517	567	567	622	220	
	5.5	112-2500	451	501	531	576	576	631	259	
	7.5	112-2000	489	539	569	614	614	669	259	
	11	112-1250	550	585	645	675	675	725	314	
	15	112-900	580	615	675	705	705	755	314	
	18.5	112-710	621	651	731	756	756	801	356	
	22	112-630	669	699	779	804	804	849	356	
	30	112-315	705	710	820	825	825	870	398	
	37	112-315	746	776	861	891	891	936	446	
	45	112-315	746	776	861	891	891	936	446	

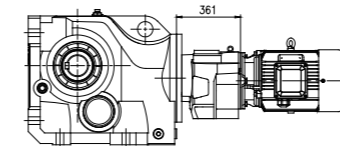

K318/C210

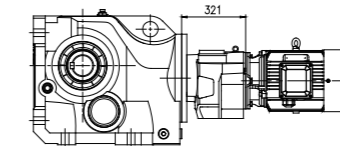

K318/C309

5.2 直连MU电机尺寸

5.2 Dimensions for Directly-connected Motor MU

K303~K318+MU

Size	P ₁ /kW	i _N	L1	L2	L3	L5	L6	L7	D
K303	0.12	4-100	206	261	241	296	/	/	124
	0.18	4-100	206	261	241	296	/	/	124
	0.25	4-100	228	268	263	323	323	358	139
	0.37	4-100	299	344	359	409	409	454	159
	0.55	4-71	299	344	359	409	409	454	159
	0.75	4-56	322	367	377	427	427	477	176
	1.1	4-3535	322	367	377	427	427	477	176
	1.5	4-28	393	433	468	508	508	563	199
	2.2	4-16	393	433	468	508	508	563	199
K304	0.18	90-125	207	262	242	297	/	/	124
	0.25	63-125	229	269	264	324	324	359	139
	0.37	40-125	300	345	360	410	410	455	159
	0.55	31.5-125	300	345	360	410	410	455	159
	0.75	22.4-112	323	368	378	428	428	478	176
	1.1	14-71	323	368	378	428	428	478	176
	1.5	7.1-50	394	434	469	509	509	564	199
	2.2	4-35.5	394	434	469	509	509	564	199
	3	4-28	459	509	534	584	584	639	220
4	4-20	470	520	550	595	595	650	259	
K305	0.25	71-112	229	269	264	324	324	359	139
	0.37	63-112	300	345	360	410	410	455	159
	0.55	40-112	300	345	360	410	410	455	159
	0.75	31.5-112	323	368	378	428	428	478	176
	1.1	25-63	323	368	378	428	428	478	176
	1.5	16-63	394	434	469	509	509	564	199
	2.2	6.3-56	394	434	469	509	509	564	199
	3	4-40	459	509	534	584	584	639	220
	4	4-28	470	520	550	595	595	650	259
K306	0.37	90-125	300	345	360	410	410	455	159
	0.55	63-125	300	345	360	410	410	455	159
	0.75	45-125	323	368	378	428	428	478	176
	1.1	31.5-90	323	368	378	428	428	478	176
	1.5	22.4-90	394	434	469	509	509	564	199
	2.2	14-80	394	434	469	509	509	564	199
	3	9-56	459	509	534	584	584	639	220
	4	7.1-40	470	520	550	595	595	650	259
	5.5	4-31.5	508	558	588	633	633	688	259

K303~K318+MU

Size	P ₁ /kW	i _N	L1	L2	L3	L5	L6	L7	D
K307	0.37	160-180	292	337	352	402	402	447	159
	0.55	112-180	292	337	352	402	402	447	159
	0.75	90-180	315	360	370	420	420	470	176
	1.1	56-112	315	360	370	420	420	470	176
	1.5	40-112	387	427	462	502	502	557	199
	2.2	28-112	387	427	462	502	502	557	199
	3	20-112	451	501	526	576	576	631	220
	4	16-80	459	509	539	584	584	639	259
	5.5	9-50	497	547	577	622	622	677	259
	7.5	7.1-40	551	586	646	681	681	736	314
	11	7.1-28	581	616	676	711	711	766	314
	0.55	160-180	283	328	343	393	393	438	159
	0.75	140-180	306	351	361	411	411	461	176
K308	1.1	100-160	306	351	361	411	411	461	176
	1.5	71-160	378	418	453	493	493	548	199
	2.2	50-160	378	418	453	493	493	548	199
	3	35.5-160	442	492	517	567	567	622	220
	4	25-140	451	501	531	576	576	631	259
	5.5	16-80	489	539	569	614	614	669	259
	7.5	8-71	550	585	645	680	680	735	314
	11	7.1-50	580	615	675	710	710	765	314
	15	7.1-35.5	621	651	731	756	756	811	356
	18.5	7.1-28	669	699	779	804	804	859	356
	1.1	140-180	303	348	358	408	408	458	176
	1.5	112-180	374	414	449	489	489	544	199
	2.2	90-180	374	414	449	489	489	544	199
K309	3	63-180	438	488	513	563	563	618	220
	4	45-180	450	500	530	575	575	630	259
	5.5	35.5-112	488	538	568	613	613	668	259
	7.5	25-112	544	579	639	674	674	729	314
	11	16-90	574	609	669	704	704	761	314
	15	9-63	615	645	725	750	750	805	356
	18.5	7.1-50	663	693	773	798	798	853	356
	22	7.1-40	705	710	820	825	825	880	398
	2.2	140-180	370	410	445	485	485	540	199
	3	112-180	434	484	509	559	559	614	220
	4	80-180	439	489	519	564	564	619	259
	5.5	56-125	477	527	557	602	602	657	259
	7.5	40-125	533	568	628	663	663	718	314
11	28-125	563	598	658	693	693	750	314	
K310	15	20-112	604	634	714	739	739	794	356
	18.5	16-90	652	682	762	787	787	842	356
	22	12.5-80	705	710	820	825	825	880	398
	30	8-50	746	776	861	891	891	946	446
	37	8-40	746	776	861	891	891	946	446

K303~K318+MU

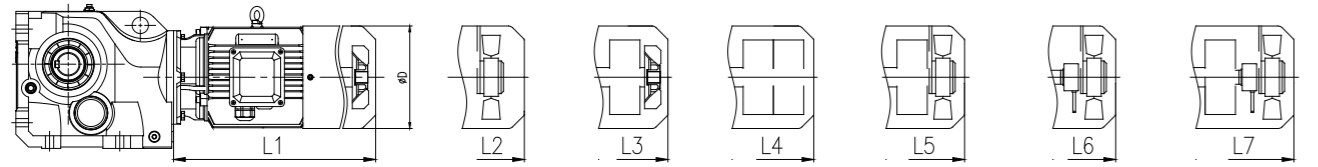

K303~K318 Fan Driven fan Brake + fan Double brake Brake + Driven fan Encoder + Driven fan Brake + Encoder + Driven fan

Size	P ₁ /kW	i _N	L1	L2	L3	L5	L6	L7	D
K312	4	140-180	429	479	509	554	554	609	259
	5.5	100-140	467	517	547	592	592	647	259
	7.5	71-140	517	552	612	647	647	702	314
	11	45-140	547	582	642	677	677	734	314
	15	35.5-140	588	618	698	723	723	778	356
	18.5	28-140	636	666	746	771	771	826	356
	22	25-112	684	689	799	804	804	859	398
	30	16-90	725	755	840	870	870	925	446
	37	9-71	725	755	840	870	870	925	446
	45	7.1-56	841	856	981	991	991	1046	485
	55	7.1-45	886	916	1026	1061	1061	1116	547
	75	7.1-35.5	937	967	1077	1112	1112	1167	547
90	7.1-28	937	967	1077	1112	1112	1167	547	
K315	7.5	100-140	502	537	597	632	632	687	314
	11	71-140	532	567	627	662	662	719	314
	15	50-140	573	603	683	708	708	763	356
	18.5	40-140	621	651	731	756	756	811	356
	22	31.5-140	674	679	789	794	794	849	398
	30	25-112	715	745	830	860	860	915	446
	37	20-100	715	745	830	860	860	915	446
	45	16-80	831	846	971	981	981	1036	485
	55	12.5-71	876	906	1016	1051	1051	1106	547
	75	10-50	927	957	1067	1102	1102	1157	547
90	10-40	927	957	1067	1102	1102	1157	547	
K316	11	125-160	532	567	627	662	662	719	314
	15	90-160	573	603	683	708	708	763	356
	18.5	80-160	621	651	731	756	756	811	356
	22	63-160	674	679	789	794	794	849	398
	30	45-112	715	745	830	860	860	915	446
	37	40-112	715	745	830	860	860	915	446
	45	31.5-112	831	846	971	981	981	1036	485
	55	25-112	876	906	1016	1051	1051	1106	547
	75	18-90	927	957	1067	1102	1102	1157	547
90	14-80	927	957	1067	1102	1102	1157	547	
K318	15	140-160	573	603	683	708	708	763	356
	18.5	112-160	621	651	731	756	756	811	356
	22	100-160	674	679	789	794	794	849	398
	30	71-140	715	745	830	860	860	915	446
	37	56-140	715	745	830	860	860	915	446
	45	45-140	831	846	971	981	981	1036	485
	55	40-140	876	906	1016	1051	1051	1106	547
	75	28-112	927	957	1067	1102	1102	1157	547
90	20-112	927	957	1067	1102	1102	1157	547	

K/C+MU

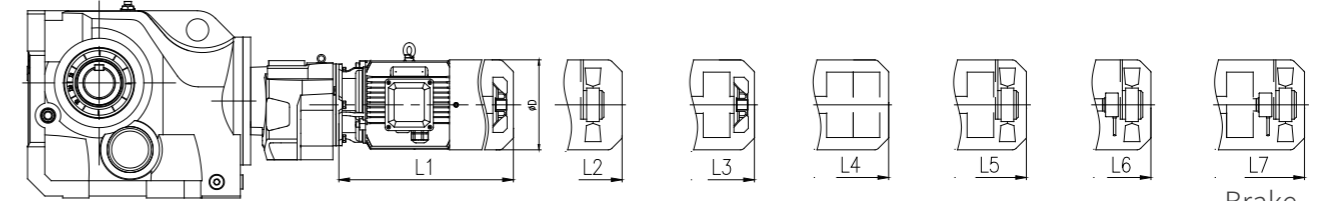

K/C combi-type Fan Driven fan Brake + fan Double brake Brake + Driven fan Encoder + Driven fan Brake + Encoder + Driven fan

Size	P ₁ /kW	i _N	L1	L2	L3	L5	L6	L7	D
K303/C.01	0.12	112-500	206	261	241	296	/	/	124
	0.18	112-250	206	261	241	296	/	/	124
	0.25	112-224	228	268	263	323	323	358	139
	0.37	112-140	299	344	359	409	409	454	139
K304/C.03	0.12	112-900	206	261	241	296	/	/	124
	0.18	112-630	206	261	241	296	/	/	124
	0.25	112-250	228	268	263	323	323	358	139
	0.37	112-250	299	344	359	409	409	454	139
K305/C.03	0.55	112-200	299	344	359	409	409	454	162
	0.12	112-1600	206	261	241	296	/	/	124
	0.18	112-900	206	261	241	296	/	/	124
K306/C.03	0.25	112-250	228	268	263	323	323	358	139
	0.37	112-250	299	344	359	409	409	454	139
	0.55	112-250	299	344	359	409	409	454	162
	0.75	112-315	322	367	377	427	427	477	162
K307/C.05	1.1	112-224	322	367	377	427	427	477	176
	1.5	112-160	393	433	468	508	508	563	176
	2.2	112	393	433	468	508	508	563	202
	0.12	112-4000	206	261	241	296	/	/	124
	0.18	112-2500	206	261	241	296	/	/	124
	0.25	112-1800	228	268	263	323	323	358	139
	0.37	112-1250	299	344	359	409	409	454	139
K308/C.05	0.55	112-800	299	344	359	409	409	454	162
	0.75	112-630	322	367	377	427	427	477	162
	1.1	112-355	322	367	377	427	427	477	176
	1.5	112-280	393	433	468	508	508	563	176
	2.2	112-200	393	433	468	508	508	563	202
	0.12	112-6300	207	262	242	297	/	/	124
	0.18	112-4000	207	262	242	297	/	/	124
	0.25	112-3150	229	269	264	324	324	359	139
	0.37	112-2000	300	345	360	410	410	455	139
	0.55	112-1250	300	345	360	410	410	455	162
K308/C.05	0.75	112-1000	323	368	378	428	428	478	162
	1.1	112-355	323	368	378	428	428	478	176
	1.5	112-355	394	434	469	509	509	564	176
	2.2	112-355	394	434	469	509	509	564	202
	3	112-250	459	509	534	584	584	639	202

K/C+MU

K/C combi-type Fan Driven fan Brake + fan Double brake Brake + Driven fan Encoder + Driven fan Brake + Encoder + Driven fan

Size	P _i /kW	i _N	L1	L2	L3	L5	L6	L7	D
K309/C. 05	0.12	112-11200	207	262	242	297	/	/	124
	0.18	112-7100	207	262	242	297	/	/	124
	0.25	112-5000	229	269	264	324	324	359	139
	0.37	112-3550	300	345	360	410	410	455	139
	0.55	112-2240	300	345	360	410	410	455	162
	0.75	112-1600	323	368	378	428	428	478	162
	1.1	112-1250	323	368	378	428	428	478	176
	1.5	112-900	394	434	469	509	509	564	176
	2.2	112-630	394	434	469	509	509	564	202
	3	112-400	459	509	534	584	584	639	202
4	112-315	470	520	550	595	595	650	220	
K310/C. 07	0.25	112-9000	221	261	256	316	316	351	139
	0.37	112-5600	292	337	352	402	402	447	139
	0.55	112-4000	292	337	352	402	402	447	162
	0.75	112-2800	315	360	370	420	420	470	162
	1.1	112-1800	315	360	370	420	420	470	176
	1.5	112-1400	387	427	462	502	502	557	176
	2.2	112-1000	387	427	462	502	502	557	202
	3	112-710	451	501	526	576	576	631	202
	4	112-560	459	509	539	584	584	639	220
	5.5	112-250	497	547	577	622	622	677	259
7.5	112-250	551	586	646	681	681	736	259	
11	112-200	581	616	676	711	711	766	314	
K312/C. 08 K312/C. 07	0.25	800-14000	221	261	256	316	316	351	139
	0.37	800-9000	292	337	352	402	402	447	139
	0.55	450-7100	292	337	352	402	402	447	162
	0.75	450-5000	315	360	370	420	420	470	162
	1.1	112-3150	315	360	370	420	420	470	176
	1.5	112-2240	387	427	462	502	502	557	176
	2.2	112-1600	378	418	453	493	493	548	202
	3	112-1120	442	492	517	567	567	622	202
	4	112-900	451	501	531	576	576	631	220
	5.5	112-400	489	539	569	614	614	669	259
	7.5	112-400	550	585	645	680	680	735	259
	11	112-315	580	615	675	710	710	765	314
	15	112-250	621	651	731	756	756	811	314
	18.5	112-200	669	699	779	804	804	859	356

K/C+MU

K/C combi-type Fan Driven fan Brake + fan Double brake Brake + Driven fan Encoder + Driven fan Brake + Encoder + Driven fan

Size	P _i /kW	i _N	L1	L2	L3	L5	L6	L7	D
K315/C. 10 K315/C. 09	0.55	450-9000	280	325	340	390	390	435	162
	0.75	450-7100	303	348	358	408	408	458	162
	1.1	112-4500	303	348	358	408	408	458	176
	1.5	112-3150	374	414	449	489	489	544	176
	2.2	112-2240	374	414	449	489	489	544	202
	3	112-1800	438	488	513	563	563	618	202
	4	112-1250	439	489	519	564	564	619	220
	5.5	112-400	477	527	557	602	602	657	259
	7.5	112-400	533	568	628	663	663	718	259
	11	112-400	563	598	658	693	693	750	314
15	112-315	604	634	714	739	739	794	314	
18.5	112-280	652	682	762	787	787	842	356	
22	112-224	705	710	820	825	825	880	356	
K316/C. 10 K316/C. 09	0.55	1800-14000	280	325	340	390	390	435	162
	0.75	1800-12500	303	348	358	408	408	458	162
	1.1	112-9000	303	348	358	408	408	458	176
	1.5	112-6300	374	414	449	489	489	544	176
	2.2	112-4500	374	414	449	489	489	544	202
	3	112-3150	438	488	513	563	563	618	202
	4	112-2240	439	489	519	564	564	619	220
	5.5	112-1800	477	527	557	602	602	657	259
	7.5	112-1250	533	568	628	663	663	718	259
	11	112-800	563	598	658	693	693	750	314
15	112-630	604	634	714	739	739	794	314	
18.5	112-450	652	682	762	787	787	842	356	
22	112-450	705	710	820	825	825	880	356	
30	112-250	746	776	861	891	891	946	398	
37	112-250	746	776	861	891	891	946	446	
K318/C. 10 K318/C. 09	0.55	1800-14000	280	325	340	390	390	435	162
	0.75	1800-14000	303	348	358	408	408	458	162
	1.1	112-12500	303	348	358	408	408	458	176
	1.5	112-10000	374	414	449	489	489	544	176
	2.2	112-6300	374	414	449	489	489	544	202
	3	112-5000	438	488	513	563	563	618	202
	4	112-3550	439	489	519	564	564	619	220
	5.5	112-2500	477	527	557	602	602	657	259
	7.5	112-2000	533	568	628	663	663	718	259
	11	112-1250	563	598	658	693	693	750	314
	15	112-900	604	634	714	739	739	794	314
	18.5	112-710	652	682	762	787	787	842	356
	22	112-630	705	710	820	825	825	880	356
	30	112-315	746	776	861	891	891	946	398
	37	112-315	746	776	861	891	891	946	446

5.3 直连MA电机尺寸

5.3 Dimensions for Directly-connected Motor MA

K303~K318+MA

Size	P ₁ /kW	i _N	L1	L2	L3	L5	L6	L7	D
K303	0.12	4-100	206	261	241	296	/	/	124
	0.18	4-100	206	261	241	296	/	/	124
	0.25	4-100	223	273	263	318	318	358	139
	0.37	4-100	223	273	263	318	318	358	139
	0.55	4-71	299	344	359	404	404	449	162
	0.75	4-56	299	344	359	404	404	449	162
	1.1	4-35.5	347	392	402	452	452	497	176
	1.5	4-28	347	392	402	452	452	497	176
	2.2	4-16	394	449	469	529	529	574	202
	3	4-11.2	394	449	469	529	529	574	202
K304	0.18	90-125	207	262	242	297	/	/	124
	0.25	63-125	224	274	264	319	319	359	139
	0.37	40-125	224	274	264	319	319	359	139
	0.55	31.5-125	300	345	360	405	405	450	162
	0.75	22.4-112	300	345	360	405	405	450	162
	1.1	14-71	348	393	403	453	453	498	176
	1.5	7.1-50	348	393	403	453	453	498	176
	2.2	4-35.5	395	450	470	530	530	575	202
	3	4-28	395	450	470	530	530	575	202
	4	4-20	459	519	534	599	599	639	220
K305	0.25	71-112	224	274	264	319	319	359	139
	0.37	63-112	224	274	264	319	319	359	139
	0.55	40-112	300	345	360	405	405	450	162
	0.75	31.5-112	300	345	360	405	405	450	162
	1.1	25-63	348	393	403	453	453	498	176
	1.5	16-63	348	393	403	453	453	498	176
	2.2	6.3-56	395	450	470	530	530	575	202
	3	4-40	395	450	470	530	530	575	202
	4	4-28	459	519	534	599	599	639	220
	K306	0.37	90-125	224	274	264	319	319	359
0.55		63-125	300	345	360	405	405	450	162
0.75		45-125	300	345	360	405	405	450	162
1.1		31.5-90	348	393	403	453	453	498	176
1.5		22.4-90	348	393	403	453	453	498	176
2.2		14-80	395	450	470	530	530	575	202
3		9-56	395	450	470	530	530	575	202
4		7.1-40	459	519	534	599	599	639	220
5.5		4-31.5	508	573	588	658	658	688	259
7.5		4-22.4	508	573	588	658	658	688	259

K303~K318+MA

Size	P ₁ /kW	i _N	L1	L2	L3	L5	L6	L7	D	
K307	0.37	160-180	216	266	256	311	311	351	139	
	0.55	112-180	292	337	352	397	397	442	162	
	0.75	90-180	292	337	352	397	397	442	162	
	1.1	56-112	340	385	395	445	445	490	176	
	1.5	40-112	340	385	395	445	445	490	176	
	2.2	28-112	387	442	462	522	522	567	202	
	3	20-112	387	442	462	522	522	567	202	
	4	16-80	451	511	526	591	591	631	220	
	5.5	9-50	497	562	577	647	647	677	259	
	7.5	7.1-40	497	562	577	647	647	677	259	
	11	7.1-28	551	601	646	701	701	736	314	
	15	7.1-20	581	631	676	731	731	766	314	
	K308	0.55	160-180	283	328	343	388	388	433	162
		0.75	140-180	283	328	343	388	388	433	162
		1.1	100-160	331	376	386	436	436	481	176
1.5		71-160	331	376	386	436	436	481	176	
2.2		50-160	378	433	453	513	513	558	202	
3		35.5-160	378	433	453	513	513	558	202	
4		25-140	442	502	517	582	582	622	220	
5.5		16-80	489	554	569	639	639	669	259	
7.5		8-71	489	554	569	639	639	669	259	
11		7.1-50	550	600	645	700	700	735	314	
15		7.1-35.5	580	630	675	730	730	765	314	
18.5		7.1-28	621	666	731	776	776	816	356	
22		7.1-25	621	666	731	776	776	816	356	
K309		1.1	140-180	328	373	383	433	433	478	176
		1.5	112-180	328	373	383	433	433	478	176
	2.2	90-180	374	429	449	509	509	554	202	
	3	63-180	374	429	449	509	509	554	202	
	4	45-180	438	498	513	578	578	618	220	
	5.5	35.5-112	488	553	568	638	638	668	259	
	7.5	25-112	488	553	568	638	638	668	259	
	11	16-90	544	594	639	694	694	729	314	
	15	9-63	574	624	669	724	724	759	314	
	18.5	7.1-50	615	660	725	770	770	810	356	
	22	7.1-40	663	708	773	818	818	858	356	
	30	7.1-28	705	725	820	845	845	890	398	
	K310	2.2	140-180	370	425	445	505	505	550	202
		3	112-180	370	425	445	505	505	550	202
		4	80-180	434	494	509	574	574	614	220
5.5		56-125	477	542	557	627	627	657	259	
7.5		40-125	477	542	557	627	627	657	259	
11		28-125	533	583	628	683	683	718	314	

K303~K318+MA

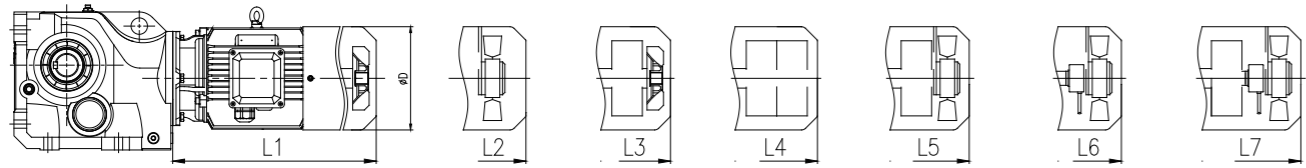

K303~K318 Fan Driven fan Brake + fan Double brake Brake + Driven fan Encoder + Driven fan Brake + Encoder + Driven fan

Size	P ₁ /kW	i _N	L1	L2	L3	L5	L6	L7	D
K310	15	20-112	563	613	658	713	713	748	314
	18.5	16-90	604	649	714	759	759	799	356
	22	12.5-80	652	697	762	807	807	847	356
	30	8-50	705	725	820	845	845	890	398
	37	8-40	746	781	861	901	901	941	446
	45	8-35.5	746	781	861	901	901	941	446
K312	4	140-180	423	483	498	563	563	603	220
	5.5	100-140	467	532	547	617	617	647	259
	7.5	71-140	467	532	547	617	617	647	259
	11	45-140	517	567	612	667	667	702	314
	15	35.5-140	547	597	642	697	697	732	314
	18.5	28-140	588	633	698	743	743	783	356
	22	25-112	636	681	746	791	791	831	356
	30	16-90	684	704	799	824	824	869	398
	37	9-71	725	760	840	880	880	920	446
	45	7.1-56	725	760	840	880	880	920	446
	55	7.1-45	841	866	981	1021	1021	1041	485
	75	7.1-35.5	886	916	1026	1066	1066	1106	547
90	7.1-28	937	967	1077	1117	1117	1157	547	
K315	7.5	100-140	467	532	547	617	617	647	259
	11	71-140	502	552	597	652	652	687	314
	15	50-140	532	582	627	682	682	717	314
	18.5	40-140	573	618	683	728	728	768	356
	22	31.5-140	621	666	731	776	776	816	356
	30	25-112	674	694	789	814	814	859	398
	37	20-100	715	750	830	870	870	910	446
	45	16-80	715	750	830	870	870	910	446
	55	12.5-71	831	856	971	1011	1011	1031	485
	75	10-50	876	906	1016	1056	1056	1096	547
90	10-40	927	957	1067	1107	1107	1147	547	
K316	11	125-160	502	552	597	652	652	687	314
	15	90-160	532	582	627	682	682	717	314
	18.5	80-160	573	618	683	728	728	768	356
	22	63-160	621	666	731	776	776	816	356
	30	45-112	674	694	789	814	814	859	398
	37	40-112	715	750	830	870	870	910	446
	45	31.5-112	715	750	830	870	870	910	446
	55	25-112	831	856	971	1011	1011	1031	485
	75	18-90	876	906	1016	1056	1056	1096	547
	90	14-80	927	957	1067	1107	1107	1147	547
K318	15	140-160	532	582	627	682	682	717	314
	18.5	112-160	573	618	683	728	728	768	356
	22	100-160	621	666	731	776	776	816	356
	30	71-140	674	694	789	814	814	859	398
	37	56-140	715	750	830	870	870	910	446
	45	45-140	715	750	830	870	870	910	446
	55	40-140	831	856	971	1011	1011	1031	485
	75	28-112	876	906	1016	1056	1056	1096	547
	90	20-112	927	957	1067	1107	1107	1147	547

K/C+MA

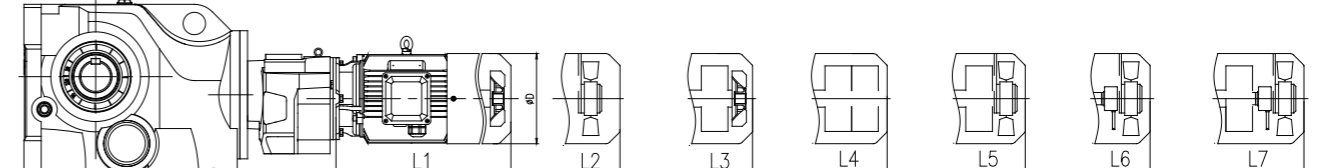

K/C combi-type Fan Driven fan Brake + fan Double brake Brake + Driven fan Encoder + Driven fan Brake + Encoder + Driven fan

Size	P ₁ /kW	i _N	L1	L2	L3	L5	L6	L7	D
K303/C. 01	0.12	112-500	206	/	/	/	/	/	124
	0.18	112-250	/	/	/	/	/	/	124
	0.25	112-224	218	/	/	/	/	/	139
	0.37	112-140	/	/	/	/	/	/	139
K304/C. 03	0.12	112-900	206	/	/	/	/	/	124
	0.18	112-630	206	/	/	/	/	/	124
	0.25	112-250	/	/	/	/	/	/	139
	0.37	112-250	218	/	/	/	/	/	139
K305/C. 03	0.55	112-200	/	/	/	/	/	/	162
	0.12	112-1600	206	/	/	/	/	/	124
	0.18	112-900	206	/	/	/	/	/	124
	0.25	112-250	/	/	/	/	/	/	139
K306/C. 03	0.37	112-250	218	/	/	/	/	/	139
	0.55	112-250	/	/	/	/	/	/	162
	0.12	112-2240	206	/	/	/	/	/	124
	0.18	112-1250	206	/	/	/	/	/	124
	0.25	112-1000	/	/	/	/	/	/	139
	0.37	112-710	218	/	/	/	/	/	139
	0.55	112-450	299	344	359	404	404	449	162
	0.75	112-315	299	344	359	404	404	449	162
	1.1	112-224	347	392	402	452	452	497	176
	1.5	112-160	347	392	402	452	452	497	176
K307/C. 03	2.2	112	394	449	469	529	529	574	202
	0.12	112-4000	206	261	241	296	/	/	124
	0.18	112-2500	206	261	241	296	/	/	124
	0.25	112-1800	223	273	263	318	318	358	139
	0.37	112-1250	223	273	263	318	318	358	139
	0.55	112-800	299	344	359	404	404	449	162
	0.75	112-630	299	344	359	404	404	449	162
	1.1	112-355	347	392	402	452	452	497	176
	1.5	112-280	347	392	402	452	452	497	176
	2.2	112-200	394	449	469	529	529	574	202
K308/C. 05	3	112-140	394	449	469	529	529	574	202
	0.12	112-6300	206	261	241	296	/	/	124
	0.18	112-4000	206	261	241	296	/	/	124
	0.25	112-3150	223	273	263	318	318	358	139
	0.37	112-2000	223	273	263	318	318	358	139
	0.55	112-1250	299	344	359	404	404	449	162
	0.75	112-1000	299	344	359	404	404	449	162
	1.1	112-355	347	392	402	452	452	497	176
	1.5	112-355	347	392	402	452	452	497	176
	2.2	112-355	394	449	469	529	529	574	202
3	112-250	394	449	469	529	529	574	202	

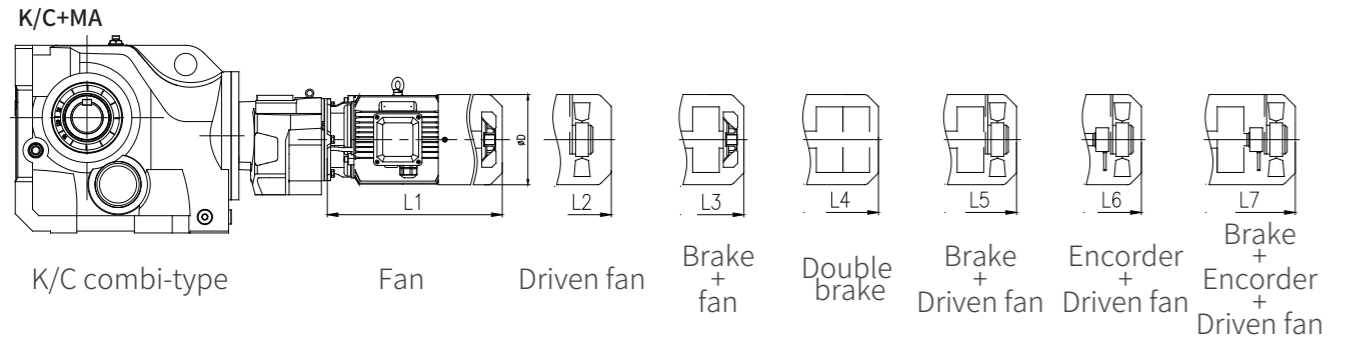

Size	P ₁ /kW	i _N	L1	L2	L3	L5	L6	L7	D
K309/C. 05	0.12	112-11200	207	262	242	297	/	/	124
	0.18	112-7100	207	262	242	297	/	/	124
	0.25	112-5000	224	274	264	319	319	359	139
	0.37	112-3550	224	274	264	319	319	359	139
	0.55	112-2240	300	345	360	405	405	450	162
	0.75	112-1600	300	345	360	405	405	450	162
	1.1	112-1250	348	393	403	453	453	498	176
	1.5	112-900	348	393	403	453	453	498	176
	2.2	112-630	395	450	470	530	530	575	202
	3	112-400	395	450	470	530	530	575	202
4	112-315	459	519	534	599	599	639	220	
K310/C. 07	0.12	112-14000	207	262	242	297	/	/	124
	0.18	112-12500	207	262	242	297	/	/	124
	0.25	112-9000	224	274	264	329	329	364	139
	0.37	112-5600	224	274	264	329	329	364	139
	0.55	112-4000	300	345	355	410	410	450	162
	0.75	112-2800	300	345	355	410	410	450	162
	1.1	112-1800	348	393	403	458	458	498	176
	1.5	112-1400	348	393	403	458	458	498	176
	2.2	112-1000	395	450	470	530	530	575	202
	3	112-710	395	450	470	530	530	575	202
	4	112-560	459	519	534	599	599	639	220
	5.5	112-250	497	562	577	647	647	677	259
	7.5	112-250	497	562	577	647	647	677	259
	11	112-200	551	601	646	701	701	926	314
	15	112-140	581	631	676	731	731	956	314
K312/C. 08 K312/C. 07	0.12	800-14000	199	254	234	289	/	/	124
	0.18	800-14000	199	254	234	289	/	/	124
	0.25	800-14000	216	266	256	321	321	356	139
	0.37	800-9000	216	266	256	321	321	356	139
	0.55	450-7100	292	337	347	402	402	442	162
	0.75	450-5000	292	337	347	402	402	442	162
	1.1	112-3150	340	385	395	450	450	490	176
	1.5	112-2240	340	385	395	450	450	490	176
	2.2	112-1600	387	442	462	522	522	567	202
	3	112-1120	387	442	462	522	522	567	202
	4	112-900	451	511	526	591	591	631	220
	5.5	112-400	489	554	569	639	639	669	259
	7.5	112-400	489	554	569	639	639	669	259
	11	112-315	550	600	645	700	700	925	314
	15	112-250	580	630	675	730	730	955	314
	18.5	112-200	621	666	731	776	776	831	356
	22	112-160	669	714	779	824	824	879	356

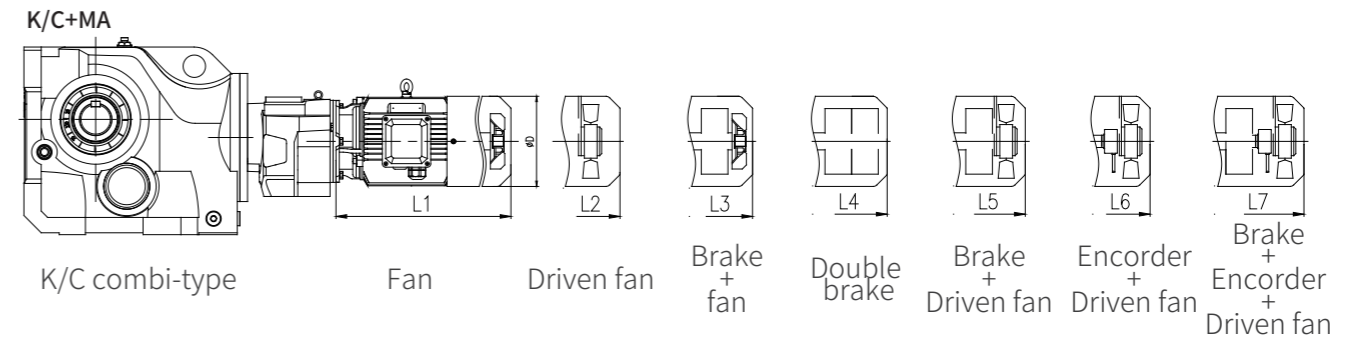

Size	P ₁ /kW	i _N	L1	L2	L3	L5	L6	L7	D
K315/C. 10 K315/C. 09	0.12	800-14000	199	254	234	289	/	/	124
	0.18	800-14000	199	254	234	289	/	/	124
	0.25	800-14000	216	266	256	321	321	356	139
	0.37	800-14000	216	266	256	321	321	356	139
	0.55	450-9000	292	337	347	402	402	442	162
	0.75	450-7100	292	337	347	402	402	442	162
	1.1	112-4500	340	385	395	450	450	490	176
	1.5	112-3150	340	385	395	450	450	490	176
	2.2	112-2240	387	442	462	522	522	567	202
	3	112-1800	387	442	462	522	522	567	202
	4	112-1250	451	511	526	591	591	631	220
	5.5	112-400	489	554	569	639	639	669	259
	7.5	112-400	489	554	569	639	639	669	259
	11	112-400	550	600	645	700	700	925	314
	15	112-315	580	630	675	730	730	955	314
18.5	112-280	621	666	731	776	776	831	356	
22	112-224	669	714	779	824	824	879	356	
K316/C. 10 K316/C. 09	0.55	1800-14000	283	328	338	393	393	433	162
	0.75	1800-12500	283	328	338	393	393	433	162
	1.1	112-9000	331	376	386	441	441	481	176
	1.5	112-6300	331	376	386	441	441	481	176
	2.2	112-4500	378	433	453	513	513	558	202
	3	112-3150	378	433	453	513	513	558	202
	4	112-2240	442	502	517	582	582	622	220
	5.5	112-1800	489	554	569	639	639	669	259
	7.5	112-1250	489	554	569	639	639	669	259
	11	112-800	550	600	645	700	700	925	314
	15	112-630	580	630	675	730	730	955	314
	18.5	112-450	604	649	714	759	759	814	356
	22	112-450	652	697	762	807	807	862	356
	30	112-250	705	725	820	845	845	905	398
	37	112-250	746	781	861	901	901	956	446
45	112-224	746	781	861	901	901	956	446	
K318/C. 10 K318/C. 09	0.55	1800-14000	283	328	338	393	393	433	162
	0.75	1800-12500	283	328	338	393	393	433	162
	1.1	112-12500	331	376	386	441	441	481	176
	1.5	112-10000	331	376	386	441	441	481	176
	2.2	112-6300	378	433	453	513	513	558	202
	3	112-5000	378	433	453	513	513	558	202
	4	112-3550	442	502	517	582	582	622	220
	5.5	112-2500	489	554	569	639	639	669	259
	7.5	112-2000	489	554	569	639	639	669	259
	11	112-1250	550	600	645	700	700	925	314
	15	112-900	580	630	675	730	730	955	314
	18.5	112-710	621	666	731	776	776	831	356
	22	112-630	669	714	779	824	824	879	356
	30	112-315	705	725	820	845	845	905	398
	37	112-315	746	781	861	901	901	956	446
45	112-315	746	781	861	901	901	956	446	

6 输入法兰和输入轴尺寸 6 Input Flange & Input Shaft
6.1 K系列AP输入法兰外形尺寸(mm) 6.1 K Series Dimensions of AP Input Flange(mm)

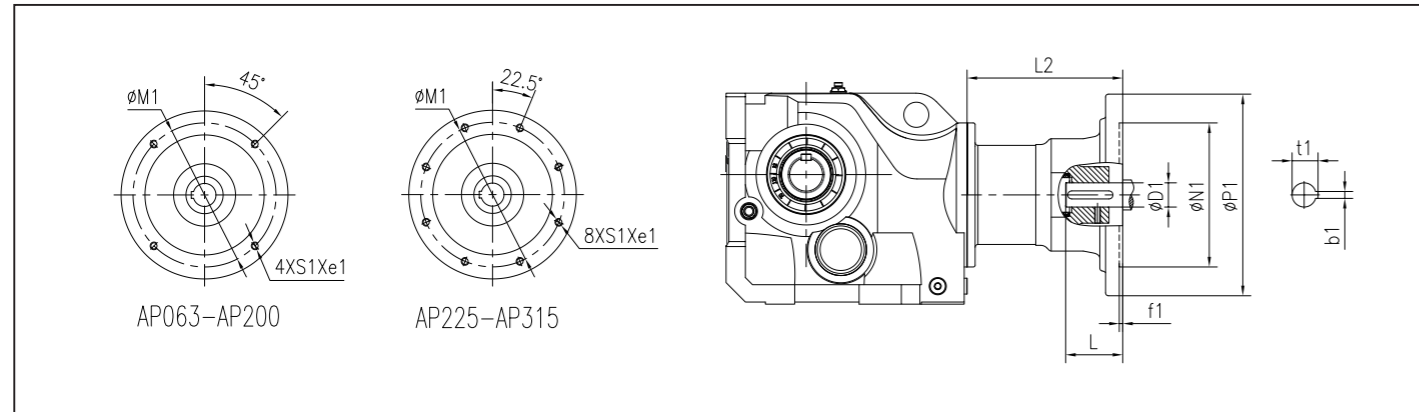

Size	Flange	i_N	e1	D1	N1	M1	P1	f1	b1	t1	L	S1	L2
K303	AP063	4-100	14	11H7	95H7	115	140	4	4	12.8	23	M8	59
	AP071	4-100	14	14H7	110H7	130	160	4	5	16.3	30	M8	59
	AP080	4-71	18	19H7	130H7	165	200	4	6	21.8	40	M10	74
K304	AP063	4-125	14	11H7	95H7	115	140	4	4	12.8	23	M8	61
	AP071	4-125	14	14H7	110H7	130	160	4	5	16.3	30	M8	61
	AP080	4-125	18	19H7	130H7	165	200	4	6	21.8	40	M10	76
	AP090	4-71	18	24H7	130H7	165	200	4	8	27.3	50	M10	81
	AP100	4-35.5	28	28H7	180H7	215	250	5	8	31.3	60	M12	190.5
K305	AP063	4-112	14	11H7	95H7	115	140	4	4	12.8	23	M8	61
	AP071	4-112	14	14H7	110H7	130	160	4	5	16.3	30	M8	61
	AP080	4-112	18	19H7	130H7	165	200	4	6	21.8	40	M10	76
	AP090	4-63	18	24H7	130H7	165	200	4	8	27.3	50	M10	81
	AP100	4-56	28	28H7	180H7	215	250	5	8	31.3	60	M12	190.5
	AP112	4-28	28	28H7	180H7	215	250	5	8	31.3	60	M12	190.5
K306	AP063	4-125	14	11H7	95H7	115	140	4	4	12.8	23	M8	61
	AP071	4-125	14	14H7	110H7	130	160	4	5	16.3	30	M8	61
	AP080	4-125	18	19H7	130H7	165	200	4	6	21.8	40	M10	76
	AP090	4-90	18	24H7	130H7	165	200	4	8	27.3	50	M10	81
	AP100	4-80	28	28H7	180H7	215	250	5	8	31.3	60	M12	190.5
	AP112	4-40	28	28H7	180H7	215	250	5	8	31.3	60	M12	190.5
	AP132	4-31.5	28	38H7	230H7	265	300	5	10	41.3	80	M12	220

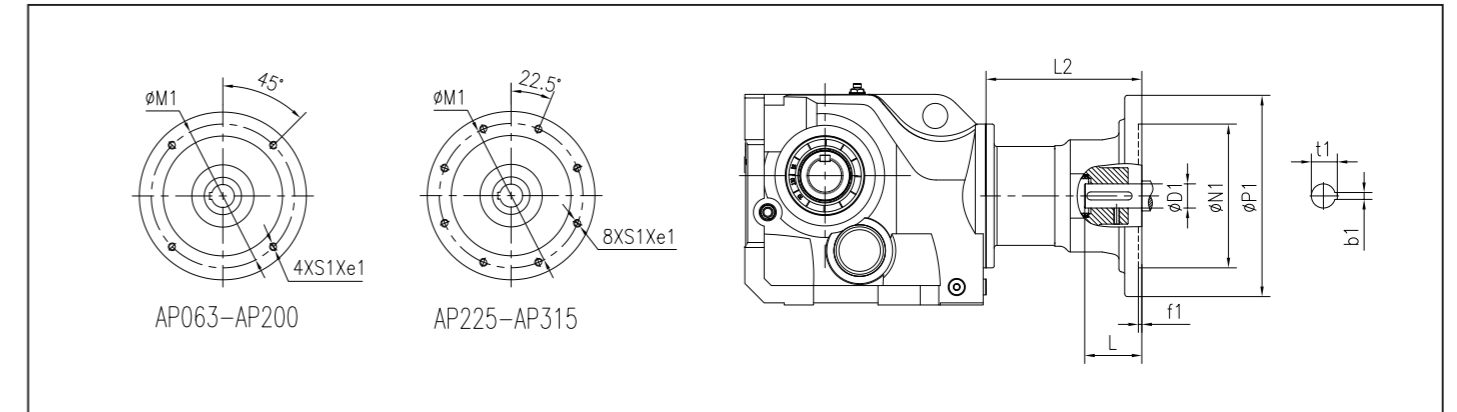

Size	Flange	i_N	e1	D1	N1	M1	P1	f1	b1	t1	L	S1	L2
K307	AP071	7.1-180	14	14H7	110H7	130	160	4	5	16.3	30	M8	53
	AP080	7.1-180	18	19H7	130H7	165	200	4	6	21.8	40	M10	68
	AP090	7.1-112	18	24H7	130H7	165	200	4	8	27.3	50	M10	73
	AP100	7.1-112	28	28H7	180H7	215	250	5	8	31.3	60	M12	180.5
	AP112	7.1-80	28	28H7	180H7	215	250	5	8	31.3	60	M12	180.5
K308	AP132	7.1-50	28	38H7	230H7	265	300	5	10	41.3	80	M12	210
	AP080	90-180	18	19H7	130H7	165	200	4	6	21.8	40	M10	65
	AP090	7.1-160	18	24H7	130H7	165	200	4	8	27.3	50	M10	66
	AP100	7.1-160	28	28H7	180H7	215	250	5	8	31.3	60	M12	170.5
	AP112	7.1-140	28	28H7	180H7	215	250	5	8	31.3	60	M12	170.5
	AP132	7.1-80	28	38H7	230H7	265	300	5	10	41.3	80	M12	203
K309	AP160	7.1-45	40	42H7	250H7	300	350	6	12	45.3	110	M16	272
	AP180	7.1-28	40	48H7	250H7	300	350	6	14	51.8	110	M16	272
	AP090	7.1-180	18	24H7	130H7	165	200	4	8	27.3	50	M10	61
	AP100	7.1-180	28	28H7	180H7	215	250	5	8	31.3	60	M12	171.5
	AP112	7.1-180	28	28H7	180H7	215	250	5	8	31.3	60	M12	171.5
	AP132	7.1-112	28	38H7	230H7	265	300	5	10	41.3	80	M12	202
	AP160	7.1-90	40	42H7	250H7	300	350	6	12	45.3	110	M16	271
	AP180	7.1-50	40	48H7	250H7	300	350	6	14	51.8	110	M16	271
K310	AP200	7.1-28	40	55H7	300H7	350	400	6	16	59.3	110	M16	327
	AP100	8-180	28	28H7	180H7	215	250	5	8	31.3	60	M12	161.5
	AP112	8-180	28	28H7	180H7	215	250	5	8	31.3	60	M12	161.5
	AP132	8-125	28	38H7	230H7	265	300	5	10	41.3	80	M12	189
	AP160	8-125	40	42H7	250H7	300	350	6	12	45.3	110	M16	258
	AP180	8-90	40	48H7	250H7	300	350	6	14	51.8	110	M16	258
	AP200	8-50	40	55H7	250H7	350	400	6	16	59.3	110	M16	327
	AP225	8-40	30	60H7	300H7	400	450	6	18	64.4	140	M16	354

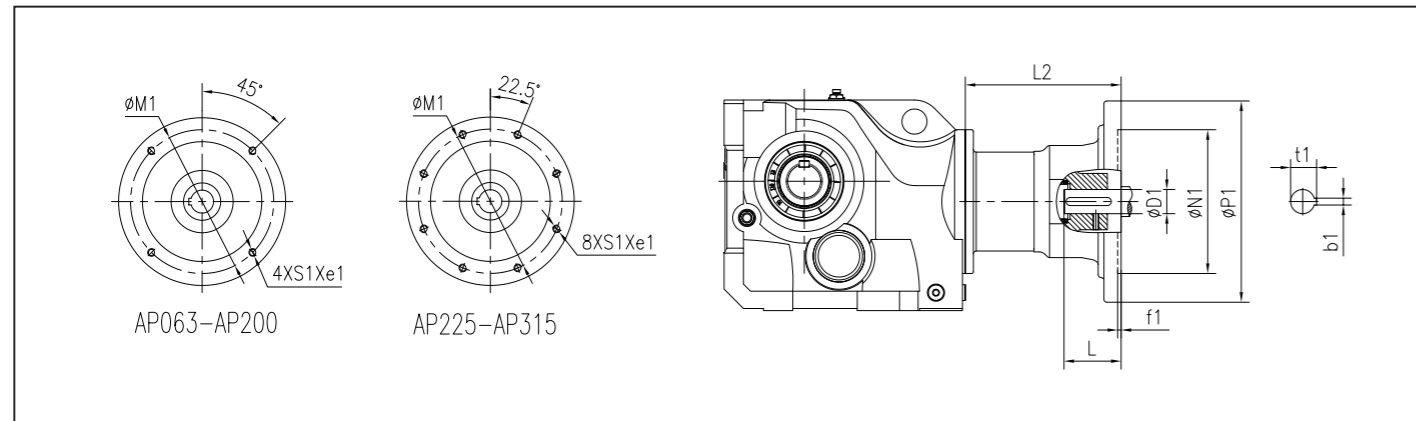

Size	Flange	i_N	e1	D1	N1	M1	P1	f1	b1	t1	L	S1	L2
K312	AP132	7.1-140	28	38H7	230H7	265	300	5	10	41.3	80	M12	175
	AP160	7.1-140	40	42H7	250H7	300	350	6	12	45.3	110	M16	244
	AP180	7.1-140	40	48H7	250H7	300	350	6	14	51.8	110	M16	244
	AP200	7.1-90	40	55H7	300H7	350	400	6	16	59.3	110	M16	316
	AP225	7.1-71	30	60H7	350H7	400	450	6	18	64.4	140	M16	343
	AP250	7.1-45	32	65H7	450H7	500	550	7	18	69.4	140	M16	361
	AP280	7.1-35.5	32	75H7	450H7	500	550	7	20	79.9	140	M16	361
K315	AP160	10-140	40	42H7	250H7	300	350	6	12	45.3	110	M16	234
	AP180	10-140	40	48H7	250H7	300	350	6	14	51.8	110	M16	234
	AP200	10-112	40	55H7	300H7	350	400	6	16	59.3	110	M16	298
	AP225	10-100	30	60H7	350H7	400	450	6	18	64.4	140	M16	325
	AP250	10-71	32	65H7	450H7	500	550	7	18	69.4	140	M16	343
	AP280	10-50	32	75H7	450H7	500	550	7	20	79.9	140	M16	343
	AP315	10-31.5	35	80H7	550H7	600	660	7	22	85.4	170	M20	447
K316	AP160	10-160	40	42H7	250H7	300	350	6	12	45.3	110	M16	234
	AP180	10-160	40	48H7	250H7	300	350	6	14	51.8	110	M16	234
	AP200	10-112	40	55H7	300H7	350	400	6	16	59.3	110	M16	298
	AP225	10-112	30	60H7	350H7	400	450	6	18	64.4	140	M16	325
	AP250	10-112	32	65H7	450H7	500	550	7	18	69.4	140	M16	343
	AP280	10-90	32	75H7	450H7	500	550	7	20	79.9	140	M16	343
	AP315	10-63	35	80H7	550H7	600	660	7	22	85.4	170	M20	447
K318	AP160	71-160	40	42H7	250H7	300	350	6	12	45.3	110	M16	234
	AP180	71-160	40	48H7	250H7	300	350	6	14	51.8	110	M16	234
	AP200	10-140	40	55H7	300H7	350	400	6	16	59.3	110	M16	298
	AP225	10-140	30	60H7	350H7	400	450	6	18	64.4	140	M16	325
	AP250	10-140	32	65H7	450H7	500	550	7	18	69.4	140	M16	343
	AP280	10-112	32	75H7	450H7	500	550	7	20	79.9	140	M16	343
	AP315	10-100	35	80H7	550H7	600	660	7	22	85.4	170	M20	447

6.2 K系列AS输入
法兰外形尺寸图表(mm)

6.2 K Series Dimensions of
AS Input Flange(mm)

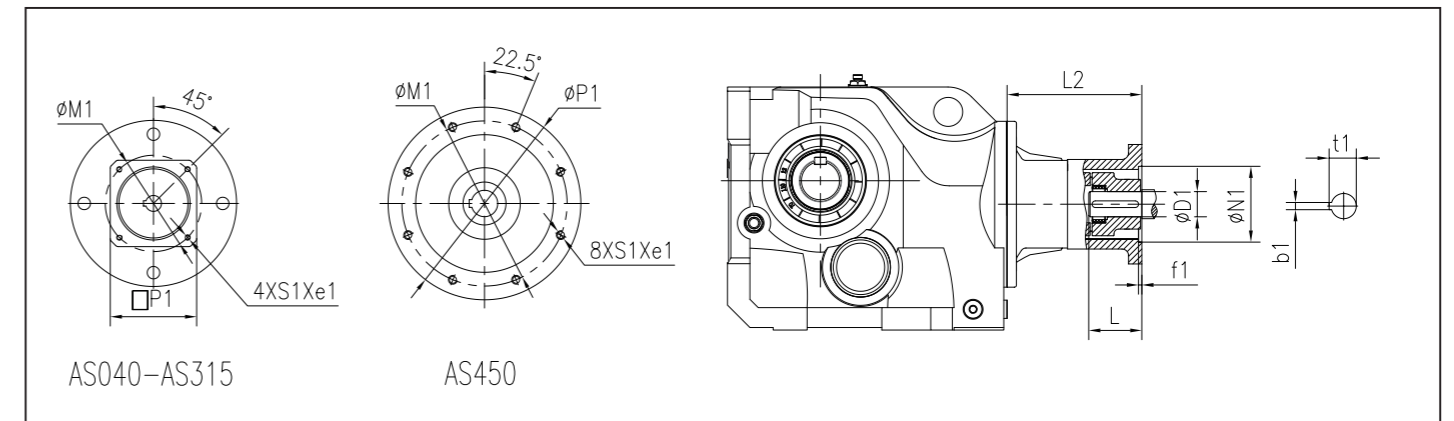

Size	Flange	i_N	e1	D1	N1	M1	P1	f1	b1	t1	L	S1	L2
K303	AS040	4-100	4	8H7	30H7	46	78	4	2	9	25	M4	70
	AS055	4-100	4	9H7	40H7	63	78	4	3	10.4	25	M5	70
	AS060	4-100	10	14H7	50H7	70	60	4	5	16.3	30	M5	114
	AS070	4-100	10	14H7	60H7	75	70	4	5	16.3	30	M5	114
	AS080	4-100	10	19H7	70H7	90	80	4	6	21.8	35	M6	120
	AS090	4-100	10	19H7	80H7	100	90	4	6	21.8	40	M6	125
	AS100	4-56	14	19H7	95H7	115	100	4	6	21.8	45	M8	122
	AS125	4-56	15	24H7	110H7	130	130	5	8	27	50	M8	133
	AS140	4-56	15	24H7	110H7	145	130	5.5	8	27	55	M8	133
	K304	AS060	4-125	10	14H7	50H7	70	60	4	5	16.3	30	M5
AS070		4-125	10	14H7	60H7	75	70	4	5	16.3	30	M5	116
AS080		4-125	10	19H7	70H7	90	80	4	6	21.8	35	M6	122
AS090		4-125	10	19H7	80H7	100	90	4	6	21.8	40	M6	127
AS100		4-80	14	19H7	95H7	115	100	4	6	21.8	45	M8	124
AS125		4-80	15	24H7	110H7	130	130	5	8	27	50	M8	135
AS140		4-80	15	24H7	110H7	145	130	5.5	8	27	55	M8	135
K305	AS060	4-112	10	14H7	50H7	70	60	4	5	16.3	30	M5	116
	AS070	4-112	10	14H7	60H7	75	70	4	5	16.3	30	M5	116
	AS080	4-112	10	19H7	70H7	90	80	4	6	21.8	35	M6	122
	AS090	4-112	10	19H7	80H7	100	90	4	6	21.8	40	M6	127
	AS100	4-63	14	19H7	95H7	115	100	4	6	21.8	45	M8	124
	AS125	4-63	15	24H7	110H7	130	130	5	8	27	50	M8	135
	AS140	4-63	15	24H7	110H7	145	130	5.5	8	27	55	M8	135
	AS160	4-63	15	32H7	130H7	165	155	5	10	35.3	60	M10	190

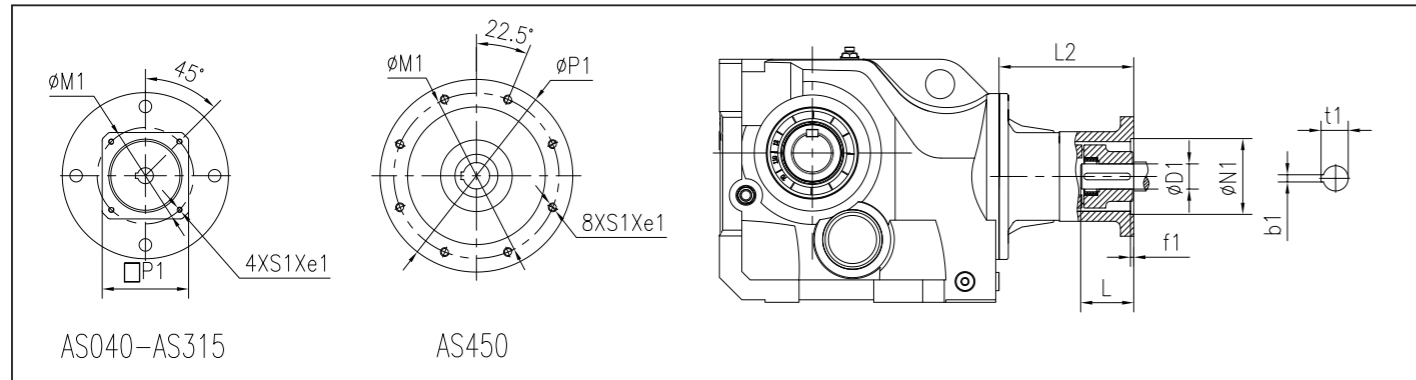

Size	Flange	i_N	e1	D1	N1	M1	P1	f1	b1	t1	L	S1	L2
K306	AS060	4-125	10	14H7	50H7	70	60	4	5	16.3	30	M5	116
	AS070	4-125	10	14H7	60H7	75	70	4	5	16.3	30	M5	116
	AS080	4-125	10	19H7	70H7	90	80	4	6	21.8	35	M6	122
	AS090	4-125	10	19H7	80H7	100	90	4	6	21.8	40	M6	127
	AS100	4-90	14	19H7	95H7	115	100	4	6	21.8	45	M8	124
	AS125	4-90	15	24H7	110H7	130	130	5	8	27	50	M8	135
	AS140	4-90	15	24H7	110H7	145	130	5.5	8	27	55	M8	135
	AS160	4-90	15	32H7	130H7	165	155	5	10	35.3	60	M10	190
K307	AS060	7.1-180	10	14H7	50H7	70	60	4	5	16.3	30	M5	108
	AS070	7.1-180	10	14H7	60H7	75	70	4	5	16.3	30	M5	108
	AS080	7.1-180	10	19H7	70H7	90	80	4	6	21.8	35	M6	114
	AS090	7.1-180	10	19H7	80H7	100	90	4	6	21.8	40	M6	119
	AS100	7.1-112	14	19H7	95H7	115	100	4	6	21.8	45	M8	116
	AS125	7.1-112	15	24H7	110H7	130	130	5	8	27	50	M8	127
	AS140	7.1-112	15	24H7	110H7	145	130	5.5	8	27	55	M8	127
	AS160	7.1-112	15	32H7	130H7	165	155	5	10	35.3	60	M10	180
	AS180	7.1-50	16	35H7	114.3H7	200	180	7	10	38.3	80	M12	210
	AS190	7.1-50	18	38H7	180H7	215	190	5	10	41.3	80	M12	210
AS240	7.1-50	28	38H7	230H7	265	240	5	10	41.3	80	M12	210	
K308	AS070	90-180	10	14H7	60H7	75	70	4	5	16.3	30	M5	105
	AS080	90-180	10	19H7	70H7	90	80	4	6	21.8	35	M6	111
	AS090	90-180	10	19H7	80H7	100	90	4	6	21.8	40	M6	116
	AS100	7.1-160	14	19H7	95H7	115	100	4	6	21.8	45	M8	113
	AS125	7.1-160	15	24H7	110H7	130	130	5	8	27	50	M8	124
	AS140	7.1-160	15	24H7	110H7	145	130	5.5	8	27	55	M8	124
	AS160	7.1-160	15	32H7	130H7	165	155	5	10	35.3	60	M10	170
	AS180	7.1-80	16	35H7	114.3H7	200	180	7	10	38.3	80	M12	203
	AS190	7.1-80	18	38H7	180H7	215	190	5	10	41.3	80	M12	203
	AS240	7.1-80	28	38H7	230H7	265	240	5	10	41.3	80	M12	203
AS260	7.1-80	40	48H7	250H7	200	260	6	14	51.8	110	M16	272	

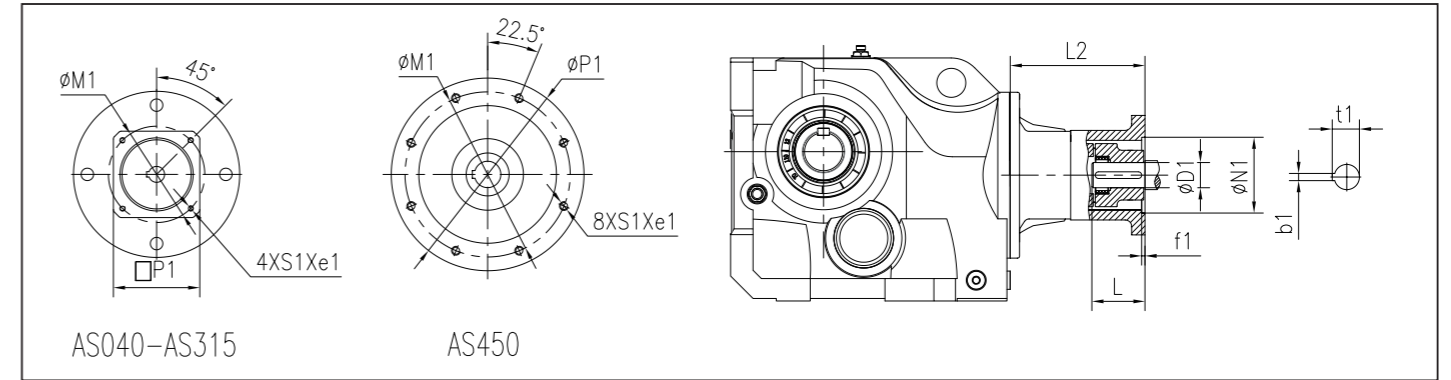

Size	Flange	i_N	e1	D1	N1	M1	P1	f1	b1	t1	L	S1	L2
K309	AS160	7.1-180	15	32H7	130H7	165	155	5	10	35.3	60	M10	171
	AS180	7.1-112	16	35H7	114.3H7	200	180	7	10	38.3	80	M12	202
	AS190	7.1-112	18	38H7	180H7	215	190	5	10	41.3	80	M12	202
	AS240	7.1-112	28	38H7	230H7	265	240	5	10	41.3	80	M12	202
	AS260	7.1-112	40	48H7	250H7	300	260	6	14	51.8	110	M16	271
	AS315	7.1-28	40	55H7	300H7	350	315	6	16	59.3	110	M16	327
K310	AS160	8-180	15	32H7	130H7	165	155	5	10	35.3	60	M10	161
	AS180	8-125	16	35H7	114.3H7	200	180	7	10	38.3	80	M12	189
	AS190	8-125	18	38H7	180H7	215	190	5	10	41.3	80	M12	189
	AS240	8-125	28	38H7	230H7	265	240	5	10	41.3	80	M12	189
	AS260	8-125	40	48H7	250H7	300	260	6	14	51.8	110	M16	258
K312	AS315	8-100	40	55H7	300H7	350	315	6	16	59.3	110	M16	327
	AS180	7.1-140	16	35H7	114.3H7	200	180	7	10	38.3	80	M12	175
	AS190	7.1-140	18	38H7	180H7	215	190	5	10	41.3	80	M12	175
	AS240	7.1-140	28	38H7	230H7	265	240	5	10	41.3	80	M12	175
	AS260	7.1-140	40	48H7	250H7	300	260	6	14	51.8	110	M16	244
	AS315	7.1-112	40	55H7	300H7	350	315	6	16	59.3	110	M16	316
K315	AS450	7.1-90	30	55H7	350H7	400	450	6	16	59.3	140	M16	343
	AS260	10-140	40	48H7	250H7	300	260	6	14	51.8	110	M16	234
	AS315	10-112	40	55H7	300H7	350	315	6	16	59.3	110	M16	298
K316	AS450	10-90	30	55H7	350H7	400	450	6	16	59.3	140	M16	325
	AS260	10-160	40	48H7	250H7	300	260	6	14	51.8	110	M16	234
K318	AS315	10-112	40	55H7	300H7	350	315	6	16	59.3	110	M16	298
	AS450	10-90	30	55H7	350H7	400	450	6	16	59.3	140	M16	325
	AS260	71-160	40	48H7	250H7	300	260	6	14	51.8	110	M16	234

6.3 K系列AN连接
法兰尺寸(mm)

6.3 K Series Dimensions of
AN Input Flange(mm)

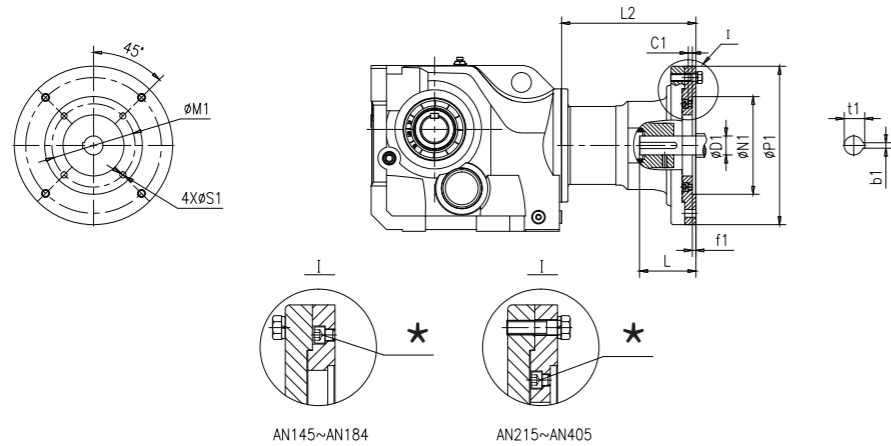

Size	AN flange	NEMA size	NEMA Power (hp)	IEC power (kW)	c1	D1	N1	M1	P1	f1	b1	t1	L	S1	L2
K303	AN145	143TC	1/1.5	0.75/1.1	6	22.225H7	114.3H7	149.2	200	5	4.76	24.7	58.04	11	92
		145TC	2	1.5											
K304	AN145	143TC	1/1.5	0.75/1.1	6	22.225H7	114.3H7	149.2	200	5	4.76	24.7	58.04	11	94
		145TC	2	1.5											
	AN184	182TC	3	2.2	8	28.575H7	215.9H7	184.2	250	8	6.35	31.7	73.03	13.5	220.5
		184TC	5	4											
K305	AN145	143TC	1/1.5	0.75/1.1	6	22.225H7	114.3H7	149.2	200	5	4.76	24.7	58.04	11	94
		145TC	2	1.5											
	AN184	182TC	3	2.2	8	28.575H7	215.9H7	184.2	250	8	6.35	31.7	73.03	13.5	220.5
		184TC	5	4											
K306	AN145	143TC	1/1.5	0.75/1.1	6	22.225H7	114.3H7	149.2	200	5	4.76	24.7	58.04	11	94
		145TC	2	1.5											
	AN184	182TC	3	2.2	8	28.925H7	215.9H7	184.2	250	8	6.35	31.7	73.3	13.5	220.5
		184TC	5	4											
	AN215	213TC	7.5	5.5	9	34.925H7	215.9H7	184.15	300	8	7.94	38.7	85.73	13.5	245
		215TC	10	7.5											
K307	AN145	143TC	1/1.5	0.75/1.1	6	22.225H7	114.3H7	149.2	200	5	4.76	24.7	58.04	11	86
		145TC	2	1.5											
	AN184	182TC	3	2.2	8	28.575H7	215.9H7	184.2	250	8	6.35	31.7	73.03	13.5	210.5
		184TC	5	4											
	AN215	213TC	7.5	5.5	9	34.925H7	215.9H7	184.15	300	8	7.94	38.7	85.73	13.5	235
		215TC	10	7.5											
K308	AN145	143TC	1/1.5	0.75/1.1	6	22.225H7	114.3H7	149.2	200	5	4.76	24.7	58.04	11	83
		145TC	2	1.5											
	AN184	182TC	3	2.2	8	28.575H7	215.9H7	184.2	250	8	6.35	31.7	73.03	13.5	200.5
		184TC	5	4											
	AN215	213TC	7.5	5.5	9	34.925H7	215.9H7	184.15	300	8	7.94	38.7	85.73	13.5	228
		215TC	10	7.5											
	AN256	254TC	15	11	9	41.275H7	215.9H7	184.15	350	8	9.53	45.8	101.6	13.5	297
		256TC	20	15											
K309	AN184	182TC	3	2.2	8	28.575H7	215.9H7	184.2	250	8	6.35	31.7	73.03	13.5	201.5
		184TC	5	4											
	AN215	213TC	7.5	5.5	9	34.925H7	215.9H7	184.15	300	8	7.94	38.7	85.73	13.5	227
		215TC	10	7.5											
	AN256	254TC	15	11	9	41.275H7	215.9H7	184.15	350	8	9.53	45.8	101.6	13.5	296
		256TC	20	15											
	AN286	284TC	25	18.5	9	47.625H7	266.7H7	228.6	400	8	12.7	53.4	117.48	13.5	352
		286TC	30	22											

★ 客户自配

★ Provided by customer

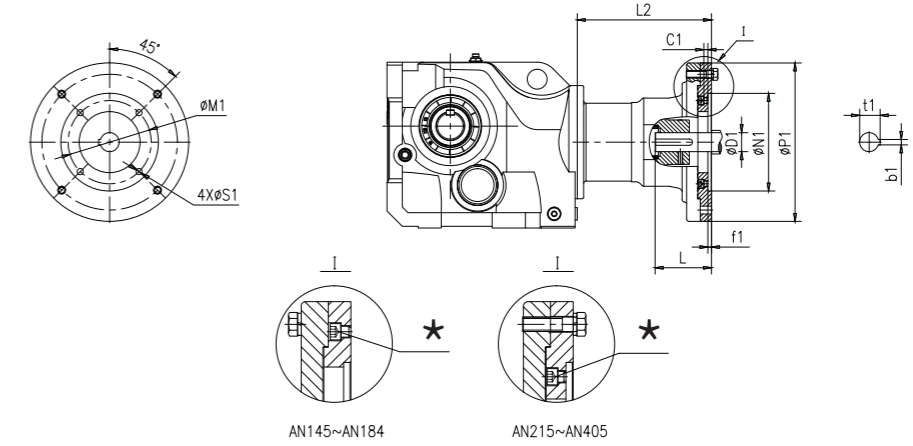

Size	AN flange	NEMA size	NEMA Power (hp)	IEC power (kW)	c1	D1	N1	M1	P1	f1	b1	t1	L	S1	L2	
K310	AN 184	182TC	3	2.2	8	28.575H7	215.9H7	184.2	250	8	6.35	31.7	73.03	13.5	191.5	
		184TC	5	4												
	AN 215	213TC	7.5	5.5	9	34.925H7	215.9H7	184.15	300	8	7.94	38.7	85.73	13.5	214	
		215TC	10	7.5												
	AN 256	254TC	15	11	9	41.275H7	215.9H7	184.15	350	8	9.53	45.8	101.6	13.5	283	
		256TC	20	15												
AN 286	284TC	25	18.5	9	47.625H7	266.7H7	228.6	400	8	12.7	53.4	117.48	13.5	252		
	286TC	30	22													
K312	AN 326	324TC	40	30	9.5	53.975H7	317.5H7	279.4	450	8	12.7	60	133.35	17.5	384	
		326TC	50	37												
	AN 365	364TC	60	45	24.5	60.325H7	317.5H7	279.4	450	8	15.88	67.6	149.23	17.5	399	
		365TC	75	55												
	K315	AN 215	213TC	7.5	5.5	9	34.925H7	215.9H7	184.15	300	8	7.94	38.7	85.73	13.5	200
			215TC	10	7.5											
AN 256		254TC	15	11	9	41.275H7	215.9H7	184.15	350	8	9.53	45.8	101.6	13.5	269	
		256TC	20	15												
AN 286		284TC	25	18.5	9	47.625H7	266.7H7	228.6	400	8	12.7	53.4	117.48	13.5	341	
		286TC	30	22												
K316	AN 326	324TC	40	30	9.5	53.975H7	317.5H7	279.4	450	8	12.7	60	133.35	17.5	373	
		326TC	50	37												
	AN 365	364TC	60	45	24.5	60.325H7	317.5H7	279.4	450	8	15.88	67.6	149.23	17.5	388	
		365TC	75	55												
	AN 405	405TC	100	75	64.5	73.025H7	317.5H7	279.4	450	8	19.05	81.9	184.15	17.5	433	
K318	AN 256	254TC	15	11	9	41.275H7	215.9H7	184.15	350	8	9.53	45.8	101.6	13.5	259	
		256TC	20	15												
	AN 286	284TC	25	18.5	9	47.625H7	266.7H7	228.6	400	8	12.7	53.4	117.48	13.5	323	
		286TC	30	22												
	AN 326	324TC	40	30	9.5	53.975H7	317.5H7	279.4	450	8	12.7	60	133.35	17.5	355	
		326TC	50	37												
AN 365	364TC	60	45	24.5	60.325H7	317.5H7	279.4	450	8	15.88	67.6	149.23	17.5	370		
	365TC	75	55													
K318	AN 256	254TC	15	11	9	41.275H7	215.9H7	184.15	350	8	9.53	45.8	101.6	13.5	259	
		256TC	20	15												
	AN 286	284TC	25	18.5	9	47.625H7	266.7H7	228.6	400	8	12.7	53.4	117.48	13.5	323	
		286TC	30	22												
	AN 326	324TC	40	30	9.5	53.975H7	317.5H7	279.4	450	8	12.7	60	133.35	17.5	355	
		326TC	50	37												
AN 365	364TC	60	45	24.5	60.325H7	317.5H7	279.4	450	8	15.88	67.6	149.23	17.5	370		
	365TC	75	55													
AN 405	405TC	100	75	64.5	73.025H7	317.5H7	279.4	450	8	19.05	81.9	184.15	17.5	415		

★ 客户自配

★ Provided by customer

6.4 K系列AE输入轴外形尺寸(mm)

6.4 K Series Dimensions of AE Input Shaft(mm)

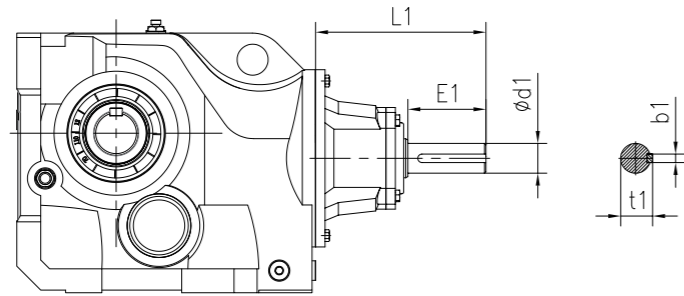

Size	Input Shaft	P ₁ (kW)	i _N	d1	E1	L1	b1	t1
K303	AE2	0.12-0.75	4-100	19k6	40	117	6	21.5
K304	AE2	0.12-0.75	4-125	19k6	40	119	6	21.5
	AE3	1.1-4	4-50	28k6	60	175	8	31
K305	AE2	0.12-0.75	4-112	19k6	40	119	6	21.5
	AE3	1.1-4	4-63	28k6	60	175	8	31
K306	AE2	0.12-0.75	4-125	19k6	40	119	6	21.5
	AE3	1.1-4	4-90	28k6	60	175	8	31
	AE4	5.5-7.5	4-31.5	38k6	80	221	10	41
K307	AE2	0.12-0.75	7.1-180	19k6	40	111	6	21.5
	AE3	1.1-4	7.1-112	28k6	60	165	8	31
	AE4	5.5-7.5	7.1-40	38k6	80	211	10	41
K308	AE2	0.12-0.75	90-180	19k6	40	108	6	21.5
	AE3	1.1-4	7.1-160	28k6	60	155	8	31
	AE4	5.5-11	7.1-71	38k6	80	204	10	41
	AE5	15-22	7.1-35.5	42k6	110	266	12	45
K309	AE3	30-45	7.1-180	28k6	60	156	8	31
	AE4	5.5-11	7.1-112	38k6	80	203	10	41
	AE5	15-22	7.1-63	42k6	110	256	12	45
	AE6	30-45	7.1-28	48k6	110	309	14	51.5
K310	AE3	1.1-4	8-180	28k6	60	146	8	31
	AE4	5.5-11	8-125	38k6	80	190	10	41
	AE5	15-22	8-112	42k6	110	252	12	45
	AE6	30-45	8-50	48k6	110	309	14	51.5
K312	AE4	5.5-11	7.1-140	38k6	80	176	10	41
	AE5	15-22	7.1-140	42k6	110	238	12	45
	AE6	30-45	7.1-90	48k6	110	298	14	51.5
	AE7	55-90	7.1-45	55k6	110	297	16	59
	AE8	110-200	7.1-25	70k6	140	377	20	74.5
K315	AE5	15-22	10-140	42k6	110	228	12	45
	AE6	30-45	10-112	48k6	110	280	14	51.5
	AE7	55-90	10-71	55k6	110	279	16	59
	AE8	110-200	10-31.5	70k6	140	361	20	74.5
K316	AE5	15-22	10-160	42k6	110	228	12	45
	AE6	30-45	10-112	48k6	110	280	14	51.5
	AE7	55-90	10-112	55k6	110	279	16	59
	AE8	110-200	10-63	70k6	140	361	20	74.5
K318	AE5	15-22	71-160	42k6	110	228	12	45
	AE6	30-45	10-140	48k6	110	280	14	51.5
	AE7	55-90	10-140	55k6	110	279	16	59
	AE8	110-200	10-100	70k6	140	361	20	74.5

7 马达防雨罩尺寸(mm)

7 Motor Rainproof Cover (mm)

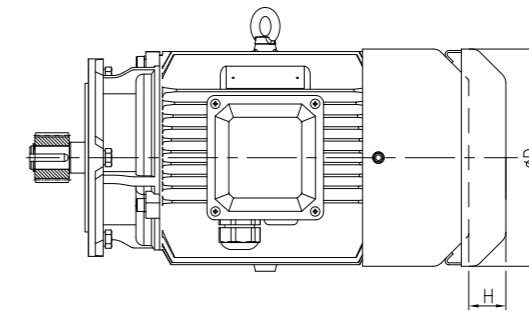

机座号 Size	H63	H71	H80	H90	H100	H112	H132	H160	H180	H200	H225	H250	H280
D	124	139	159	176	199	220	259	314	356	398	446	485	547
H	25	30	30	35	40	40	40	60	60	70	70	80	80

8 被驱动轴推荐尺寸(mm) 8 Recommended Dimensions for Driven Equipment Shaft (mm)

8.1 锁紧盘

8.1 Shrink Disk

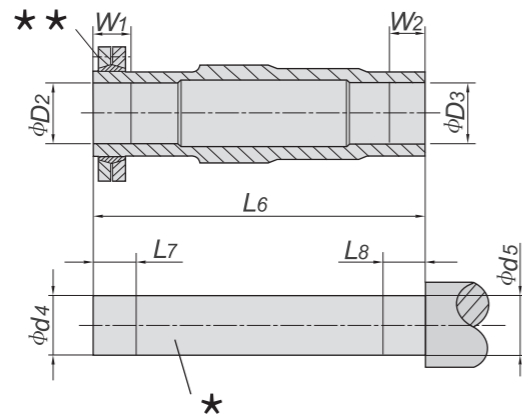

规格 Size	D2	D3	d4	d5	L6	L7	L8	W1	W2	型号 Type	锁紧盘 Shrink Disk 螺栓 Bolt	锁紧盘 Shrink Disk 重量(kg) Weight (kg)
K303	30H7	30H7	30h6	30h6	146	35	25	30	20	SP2-44×80	M6	0.6
K304	35H7	35H7	35h6	35h6	177	35	25	30	20	SP2-44×80	M6	0.6
K305	40H7	40H7	40h6	40h6	195	40	30	35	25	SP2-50×90	M6	0.8
K306	40H7	40H7	40h6	40h6	208	43	25	38	20	SP2-50×90	M6	0.8
K307	50H7	50H7	50h6	50h6	241	41	35	36	30	SP2-62×110	M6	1.3
K308	65H7	65H7	65h6	65h6	281	46	45	41	40	SP2-80×145	M8	1.9
K309	75H7	75H7	75h6	75h6	345	60	55	55	50	SP2-90×155	M8	3.3
K310	95H7	95H7	95h6	95h6	405	75	70	65	60	SP2-110×185	M10	5.9
K312	105H7	105H7	105h6	105h6	485	95	80	85	70	SP2-140×230	M12	10
K315	125H7	125H7	125h6	125h6	580	100	87	90	77	SP2-155×263	M12	15
K316	135H7	140H7	135h6	140h6	728	130	100	122	90	SP2-175×300	M16	22
K318	155H7	160H7	155h6	160h6	790	130	105	119	95	SP2-195×350	M16	41

★ 被驱动轴
★★ 螺栓

★ Driven Equipment Shaft
★★ Driven Equipment Shaft

8.2 花键轴

8.2 Involute Spline

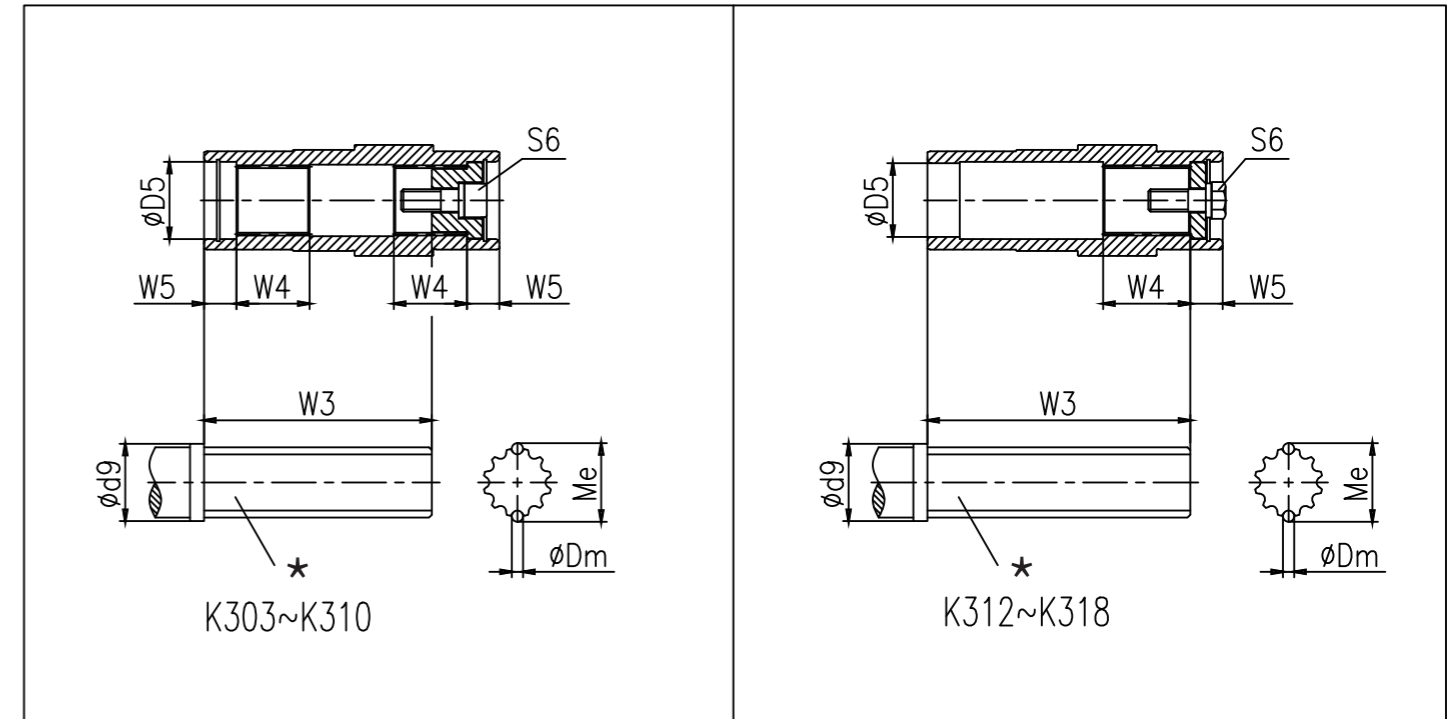

Size	D5	Dm	d9	Me	W3	W4	W5	S6
k303	37	2.75	42	33.03	85	25	18	M10×30
k304	37	4	42	38.92	115	32	18	M10×30
k305	42	4	47	38.92	125	42	25	M16×40
k306	42	4	47	38.92	140	42	25	M16×40
k307	55	4	62	54.13	160	52	23	M16×50
k308	72	4	82	68.96	180	62	25	M20×60
k309	72	4	90	74.15	240	72	25	M24×60
k310	90	6	105	91	290	89	26	M24×60
k312	100	6	120	101.05	380	92	28	M24×60
k315	120	6	140	125.99	468	107	30	M24×70
k316	145	6	165	146.06	585	128	23	M30×80
K318	155	6	175	146.06	650	128	23	M30×80

★ 被驱动轴

★ Driven Equipment Shaft

9 轴端C型螺纹中心孔

9 Type C screw central hole in shaft end

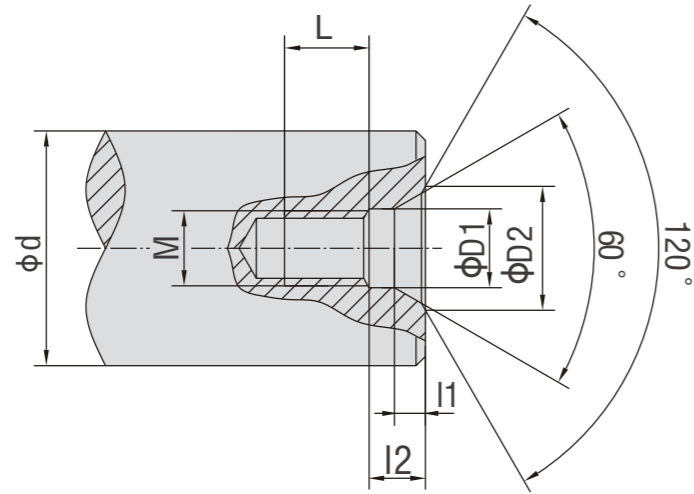

d	M	L	l2	l1	D1	D2
7 < d ≤ 10	M3	10	2.6	1.8	3.2	5.8
10 < d ≤ 13	M4	10	3.2	2.1	4.3	7.4
13 < d ≤ 16	M5	10	4	2.4	5.3	8.8
16 < d ≤ 21	M6	12	5	2.8	6.4	10.5
21 < d ≤ 24	M8	12	6	3.3	8.4	13.2
24 < d ≤ 30	M10	15	7.5	3.8	10.5	16.3
30 < d ≤ 38	M12	20	9.5	4.4	13	19.8
38 < d ≤ 50	M16	25	12	5.2	17	25.3
50 < d ≤ 85	M20	30	15	6.4	21	31.3
85 < d ≤ 130	M24	35	18	8	25	38
130 < d ≤ 225	M30	45	18	11	31	48

10 平键与键槽的尺寸 (mm)

10 Dimension of Parallel Key and Keyway (mm)

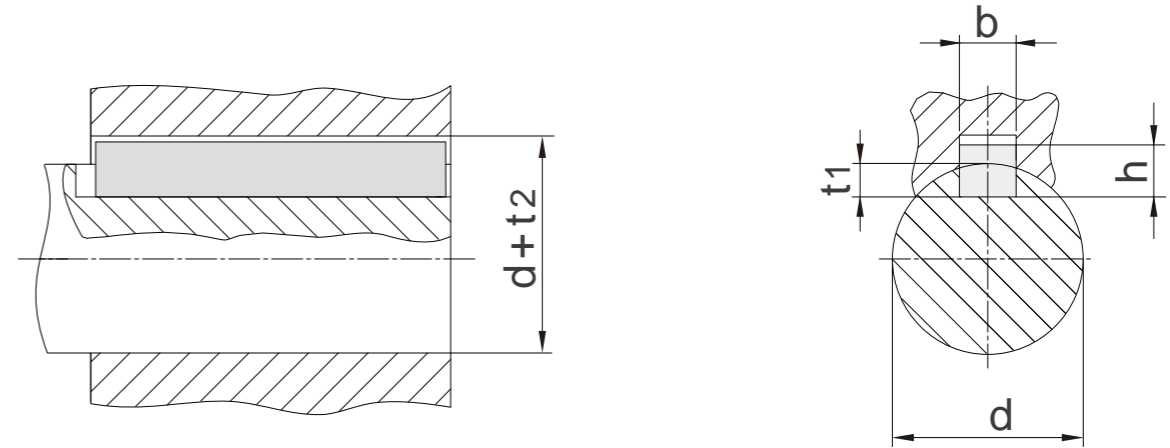

d	b	h	t1	d + t2
8 < d ≤ 10	3	3	1.8	d + 1.4
10 < d ≤ 12	4	4	2.5	d + 1.8
12 < d ≤ 17	5	5	3	d + 2.3
17 < d ≤ 22	6	6	3.5	d + 2.8
22 < d ≤ 30	8	7	4	d + 3.3
30 < d ≤ 38	10	8	5	d + 3.3
38 < d ≤ 44	12	8	5	d + 3.3
44 < d ≤ 50	14	9	5.5	d + 3.8
50 < d ≤ 58	16	10	6	d + 4.3
58 < d ≤ 65	18	11	7	d + 4.4
65 < d ≤ 75	20	12	7.5	d + 4.9
75 < d ≤ 85	22	14	9	d + 5.4
85 < d ≤ 95	25	14	9	d + 5.4
95 < d ≤ 110	28	16	10	d + 6.4
110 < d ≤ 130	32	18	11	d + 7.4
130 < d ≤ 150	36	20	12	d + 8.4
150 < d ≤ 170	40	22	13	d + 9.4
170 < d ≤ 200	45	25	15	d + 10.4
200 < d ≤ 230	50	28	17	d + 11.4
230 < d ≤ 260	56	32	20	d + 12.4

11. 可选附件和指定配置

11.1 齿轮常规安装 常规供货无需说明

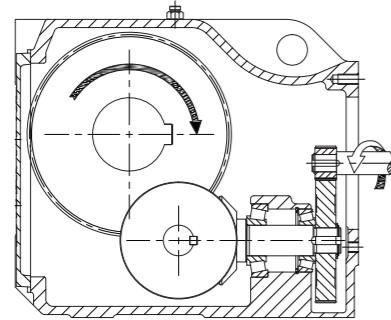

11. Accessories and Specific Configuration

11.1 Conventional Installation of Gear Standard Installation do not have to be indicated

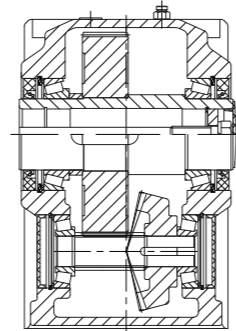

逆止器选项和 K 系列输出形式关系		Relationship of backstop & K series output mode	
输出形式 Output mode	输出轴旋向(面向输出轴端面) Output shaft rotational direction(when facing to it)		逆止器 Backstop
A/D/G/I/K	CW		P
	CCW		Q
B/E/H/J/L	CW		Q
	CCW		P

注意: CW为顺时针, CCW为逆时针
P为逆止器顺时针, Q为逆止器逆时针

Attention: CW is clockwise while CCW is counter-clockwise.
P is clockwise for the backstop, Q is counter-clockwise.

11.2 齿轮非常规安装

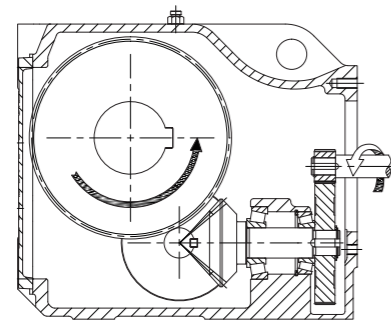

11.2 Unconventional Installation of Gear

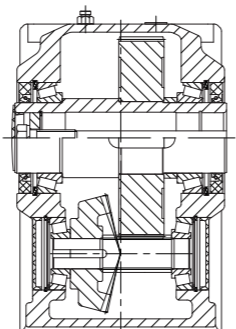

逆止器选项和 K 系列输出形式关系(非常规安装)		Relationship of backstop & K series output mode (for Unconventional Installation of Gear)	
输出形式 Output mode	输出轴旋向(面向输出轴端面) Output shaft rotational direction(when facing to it)		逆止器 Backstop
A/D/G/I/K	CW		Q
	CCW		P
B/E/H/J/L	CW		P
	CCW		Q

注意: 齿轮非常规安装情况下, 逆止器和输出轴旋向关系与常规安装时结果相反!
CW为顺时针, CCW为逆时针
P为逆止器顺时针, Q为逆止器逆时针

Attention: With unconventional installation of gear, relationship of backstop and output modes should be opposite of conventional installation results!
CW is clockwise while CCW is counter-clockwise.
P is clockwise for the backstop, Q is counter-clockwise.

11.3 补偿油箱 (代号6)

齿轮马达在以下工况时采用补偿油箱润滑:
1. 安装方位为D4时, 出厂标配补偿油箱;

11.3 Oil Compensating Tank (Code 6)

Oil compensating tank lubrication is configured for gearmotors under working conditions below:
1. When mounting position is D4, oil compensating tank has been installed before delivery;

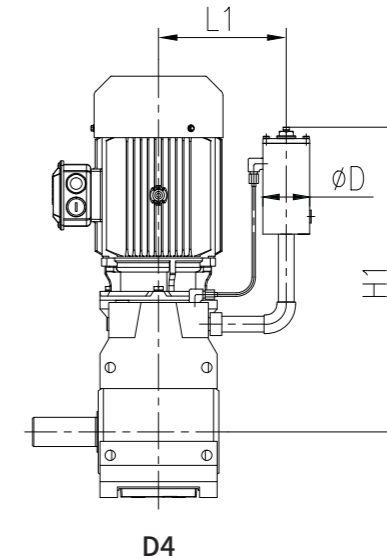

Size	D	L1	H1
K303	42	100	315
K304	42	115	340
K305	42	120	345
K306	42	120	345
K307	80	160	520
K308	80	175	585
K309	80	200	595
K310	120	270	750
K312	120	305	810
K315	120	325	800
K316	120	340	945
K318	120	365	945

12 润滑油(L)
12.1 K303~K318

12 Oil (L)
12.1 K303~K318

Size \ Mounting position	D1	D2	D3	D4	D5	D6
K303	0.8	0.8	0.7	0.9	0.8	0.8
K304	1.2	1.1	1.2	1.6	1.3	1.3
K305	2.2	1.7	1.2	2.5	2.1	2.1
K306	2.2	1.6	1.6	2.6	1.9	1.9
K307	2.9	3.9	3.1	5.4	4.5	4.5
K308	5.2	6.6	8	10	8	8
K309	11	12	15	19	15	15
K310	17	21	25	33	25	24
K312	28	37	41	55	41	40
K315	50	61	68	90	72	71
K316	77	84	109	143	114	110
K318	103	113	155	202	158	158

12.2 K&C组合型

12.2 K&C combi-type

Size \ Mounting position	D1	D2	D3	D4	D5	D6
K303&C201	0.8+0.4	0.8+0.4	0.7+0.4	0.9+0.5	0.8+0.4	0.8+0.4
K303&C301	0.8+0.3	0.8+0.3	0.7+0.3	0.9+0.4	0.8+0.3	0.8+0.3
K304&C203	1.2+0.4	1.1+1	1.2+1.1	1.6+1.2	1.3+0.9	1.3+1.1
K304&C303	1.2+0.3	1.1+0.9	1.2+0.9	1.6+1	1.3+0.8	1.3+0.9
K305&C203	2.2+0.4	1.7+1	1.2+1.1	2.5+1.2	2.1+0.9	2.1+1.1
K305&C303	2.2+0.3	1.7+0.9	1.2+0.9	2.5+1	2.1+0.8	2.1+0.9
K306&C203	2.2+0.4	1.6+1	1.6+1.1	2.6+1.2	1.9+0.9	1.9+1.1
K306&C303	2.2+0.3	1.6+0.9	1.6+0.9	2.6+1	1.9+0.8	1.9+0.9
K307&C203	2.9+0.4	3.9+1	3.1+1.1	5.4+1.2	4.5+0.9	4.5+1.1
K307&C303	2.9+0.3	3.9+0.9	3.1+0.9	5.4+1	4.5+0.8	4.5+0.9
K308&C205	5.2+1.5	6.6+1.7	8+1.8	10+1.8	8+2.6	8+2.5
K308&C305	5.2+1.3	6.6+1.4	8+1.5	10+1.5	8+2.2	8+2.1
K309&C205	11+1.5	12+1.7	15+1.8	19+1.8	15+2.6	15+2.5
K309&C305	11+1.3	12+1.4	15+1.5	19+1.5	15+2.2	15+2.1
K310&C207	17+2	21+2.9	25+2.8	33+3.1	25+3.6	24+3.5
K310&C307	17+1.7	21+2.5	25+2.4	33+2.6	25+3.1	24+3
K312&C207	28+2	37+2.9	41+2.8	55+3.1	41+3.6	40+3.5
K312&C208	28+2.6	37+7.1	41+7.5	55+8.1	41+6.6	40+7.2
K303&C307	28+1.7	37+2.5	41+2.4	55+2.6	41+3.1	40+3
K315&C209	50+3.9	61+6.4	68+5.5	90+6	72+7.8	71+7.5
K315&C210	50+6.5	61+16.8	68+17.4	90+19.7	72+13.7	71+17.1
K315&C309	50+3.3	61+5.4	68+4.7	90+5.1	72+6.6	71+6.4
K316&C209	77+7.8	84+9.7	109+9.5	143+10.1	114+13.1	110+12.8
K316&C210	77+6.5	84+16.8	109+17.4	143+19.7	114+13.7	110+17.1
K316&C309	77+6.6	84+8.2	109+8.1	143+8.6	114+11.1	110+10.9
K318&C209	103+7.8	113+9.7	155+9.5	202+10.1	158+13.1	158+12.8
K318&C210	103+6.5	113+16.8	155+17.4	202+19.7	158+13.7	158+17.1
K318&C309	103+6.6	113+8.2	155+8.1	202+8.6	158+11.1	158+10.9

注:K和C组合产品需分别加注润滑油

Attention: Please supply lubricant oil for both K part and C part of the combination

13 重量表

13.1 齿轮箱及直连马达重量表 (Kg)

13 Weight

13.1 Weight of Gearbox & Directly-connected Motor (kg)

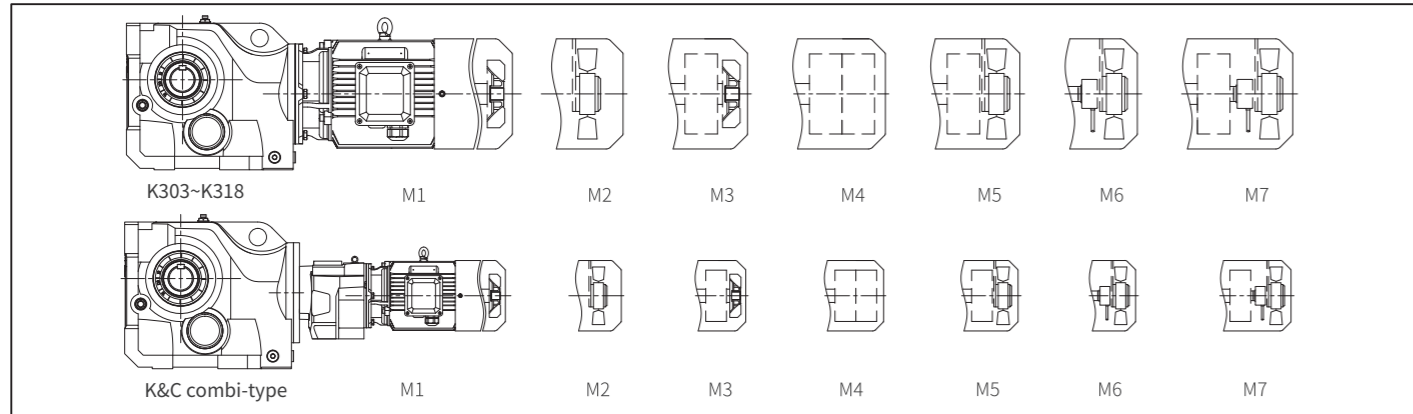

- | | |
|------------------|------------------------------|
| M1: 自扇冷却 | M1: Self-fan cooling |
| M2: 强冷风机 | M2: Driven fan |
| M3: 制动器+自扇冷却 | M3: Brake+Self-fan cooling |
| M4: 双制动器 | M4: Double brake |
| M5: 制动器+强冷风机 | M5: Brake+Driven fan |
| M6: 编码器+强冷风机 | M6: Encoder+Driven fan |
| M7: 制动器+编码器+强冷风机 | M7: Brake+Encoder+Driven fan |

齿轮箱重量表 (Kg)		Weight of Gearbox					
规格 Size		K303	K304	K305	K306	K307	K308
重量 Weight		14	23	32	39	67	108
规格 Size		K309	K310	K312	K315	K316	K318
重量 Weight		174	280	496	759	1300	1688
规格 Size		K303&C201 K303&C301	K304&C203 K304&C303	K305&C203 K305&C303	K306&C203 K306&C303	K307&C203 K307&C303	K308&C205 K308&C305
重量 Weight		22	32	41	48	76	128
规格 Size		K309&C205 K309&C305	K310&C207 K310&C307	K312&C207 K312&C307	K315&C209 K315&C309	K316&C209 K316&C309	K318&C209 K318&C309
重量 Weight		194	316	532	825	1420	1808

直连马达重量表 (Kg)		Weight of Directly-connected Motor (kg)																											
4-pole Power		MH							MP							MU							MA						
		M1	M2	M3	M4	M5	M6	M7	M1	M2	M3	M5	M6	M7	M1	M2	M3	M5	M6	M7	M1	M2	M3	M5	M6	M7			
0.12	7	8	9	/	9	/	/	7	8	9	9	/	/	7.5	8	9	9.5	/	/	7	8	9	9	/	/				
0.18	7	8	9	/	9	/	/	8	9	10	10	/	/	7.5	8	9	9.5	/	/	8	9	10	10	/	/				
0.25	8	9	10	/	11	10	12	9	10	11	12	11	13	9.5	10.5	11	12	11	13	9	10	11	12	11	13				
0.37	9	10	11	/	12	11	13	10	11	12	13	12	14	15	16	19	20	16.5	21	10	11	12	13	12	14				
0.55	14	15	18	/	19	16	20	15	16	19	20	17	21	16	17	20	21	17.5	22	15	16	19	20	17	21				
0.75	15	16	19	/	20	17	21	16	17	20	21	18	22	20	21	24	25	21.5	26	16	17	20	21	18	22				
1.1	18	19	22	/	23	20	24	20	21	24	25	22	26	22	23	26	27	23.5	28	21	22	25	26	23	27				
1.5	19	20	23	/	24	21	25	22	23	26	27	24	28	31	32	39	40	33	41	23	24	27	28	25	29				
2.2	30	31	38	/	39	32	40	32	33	40	41	34	42	34	35	42	43	36	44	36	37	44	45	38	45				
3	33	34	41	/	42	35	43	36	37	44	45	38	46	55	57	63	64	58	65	36	37	44	45	38	45				
4	52	53	60	/	61	54	62	56	57	64	65	58	66	75	77	87	89	78	90	56	57	64	65	58	66				
5.5	67	69	78	/	80	70	81	77	79	88	90	80	91	78	80	89	91	81	92	77	79	88	90	80	91				
7.5	80	82	91	/	93	83	94	88	90	99	101	91	102	128	130	149	151	131	152	88	90	99	101	91	102				
11	121	123	142	/	162	143	124	144	129	131	150	151	132	152	160	162	181	183	163	184	129	131	150	151	132	152			
15	139	141	160	/	180	161	142	162	161	163	182	183	164	184	198	200	230	232	201	234	161	163	182	183	164	184			
18.5	182	184	214	/	246	215	185	217	200	202	232	233	203	235	218	220	250	252	221	254	200	202	232	233	203	235			
22	204	206	236	/	268	237	207	239	220	222	252	253	223	255	279	280	329	330	281	332	220	222	252	253	223	255			
30	260	260	310	/	360	308	261	310	280	280	330	328	281	330	343	345	393	394	346	396	280	280	330	328	281	330			
37	330	332	380	/	381	334	383	345	347	395	396	349	398	365	367	415	416	368	418	345	347	395	396	349	398				
45	345	347	395	/	396	349	398	365	367	415	416	369	418	467	469	572	573	470	575	365	367	415	416	369	418				
55	435	436	540	/	535	436	537	470	471	575	570	471	572	627	629	732	734	630	736	470	471	575	570	470	572				
75	575	577	680	/	678	578	680	630	632	735	733	633	735	650	652	755	757	653	759	630	632	735	733	633	735				
90	645	647	750	/	748	648	750	710	712	815	813	713	815	720	722	825	827	723	829	710	712	815	813	713	815				

13.2 输入法兰及输入轴重量表 (Kg)

13.2 Weight of Input Flange & Input Shaft (kg)

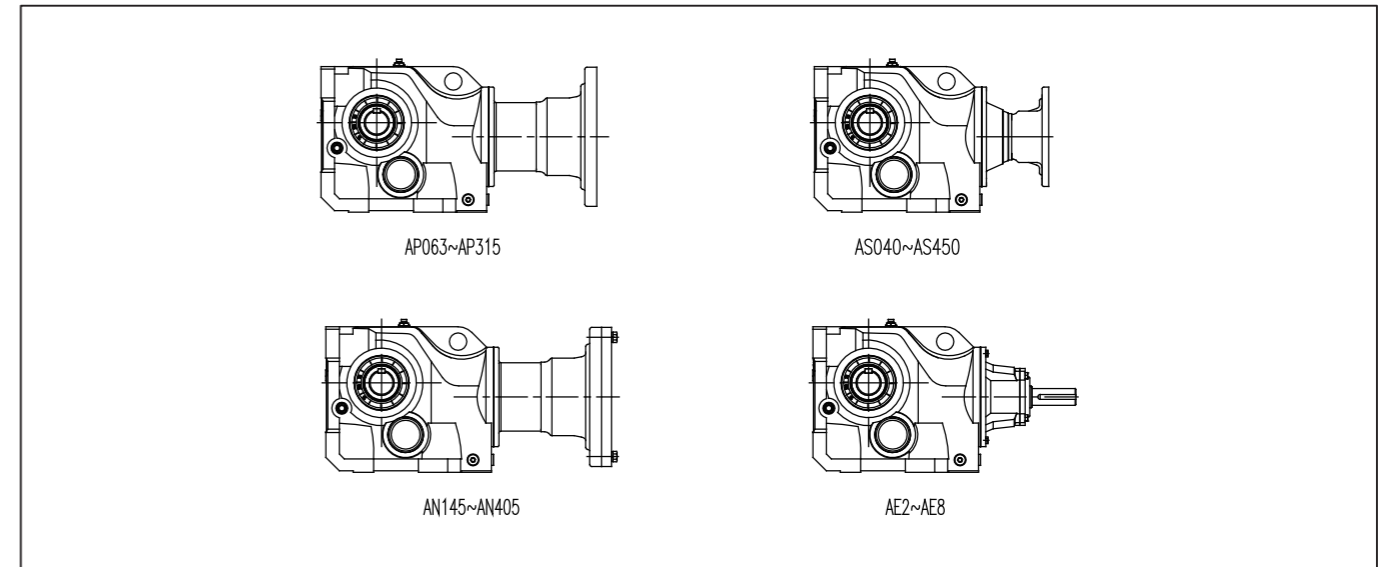

AP输入法兰重量表 (kg)		Weight of AP Input Flange (kg)						
规格 Size		AP063	AP071	AP080	AP090	AP100	AP112	AP132
重量 Weight		5	5	9	11	18	18	30
规格 Size		AP160	AP180	AP200	AP225	AP250	AP280	AP315
重量 Weight		70	70	95	107	144	144	263

AS输入法兰重量表 (kg)		Weight of AS Input Flange (kg)							
规格 Size		AS040	AS055	AS060	AS070	AS080	AS090	AS100	AS125
重量 Weight		3	3	4	5	5	5	6	7
规格 Size		AS140	AS160	AS180	AS190	AS240	AS260	AS315	AS450
重量 Weight		6	13	24	25	30	70	95	112

AN输入法兰重量表 (kg)		Weight of AN Input Flange (kg)							
规格 Size		AN145	AN184	AN215	AN256	AN286	AN326	AN365	AN405
重量 Weight		13	27	43	89	119	140	154	201

AE输入轴重量表 (kg)		Weight of AE Input Shaft (kg)							
规格 Size		AE2	AE3	AE4	AE5	AE6	AE7	AE8	
重量 Weight		4	9	17	46	63	77	101	

随着技术迭代进步，博能产品样本将会同步更新，请见谅。
Along with the technology advancedet.,the product of the manual of Boneng will be changed,please forgive.

控制层 CONTROL

驱动层 DRIVE

马达层 MOTOR

齿轮层 GEAR



X3010 PLC
EtherCAT&Modbus
24VDC



X3050 运动控制器
Motion Controller
EtherCAT&Modbus
24VDC

C/F/K/S-M
* . . . D
马达分布式变频驱动器
Integrated Gearmotor Drive

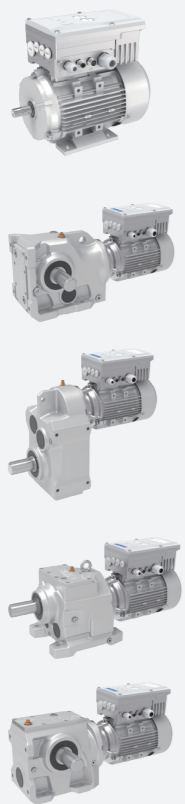

EtherCAT&Modbus
380~480VAC
0.25~3kW
i=4~355

AM 变频驱动器
Variable Frequency Drive



Modbus
380~480VAC
0.75~5.5kW

A1 变频驱动器
Variable Frequency Drive



Modbus/CANopen/
PROFINET
380~480VAC
0.75~250kW

C/F/K/S/R
齿轮马达
Gearmotor



380~480VAC
0.09~200kW
i=1.25~500

MP/MU/MA
三相交流异步马达
Asynchronous Motor



380~480VAC
0.09~90kW
960/1450r/min
1160/1750r/min

HB/BE/HK
齿轮箱
Gearbox



4.2~15775kW
i=5.6~450

P/PK
行星齿轮箱
Planetary Gearbox



0.4~14000kW
i=25~4000

PW
卷扬齿轮箱
Planetary Winch Gearbox

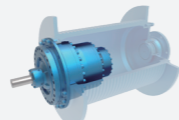

1~1810kW
i=13~940

PS
回转齿轮箱
Planetary Slewing Gearbox



1~1626kW
i=14~947

J/JB
升降机
Jack



0.35~22.63kW
i=5~34

T
转向箱
Spiral Bevel Gearbox

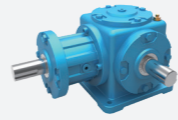

0.08~303kW
i=1:1~3:1

MX&AX
伺服马达&伺
服驱动器
Permanent
Magnet
Servo Motor
& Servo Drive



EtherCAT/
PROFINET
380~480VAC
0.28~14kW
1500/2000r/min
3000/4500r/min

C/F/K/S-MX
&AX齿轮伺
服马达&伺
服驱动器
Servo
Gearmotor
& Servo Drive



EtherCAT/
PROFINET
380~480VAC
0.28~14kW
i=1.25~315

PX-MX&AX
行星伺服马达
&伺服驱动器
Planetary
Precision Gear
Servo Motor
& Servo Drive



EtherCAT/
PROFINET
380~480VAC
0.38~14kW
i=3~100

PN-MN&AN
行星伺服马达
&伺服驱动器
Planetary
Precision Gear
Servo Motor
& Servo Drive



EtherCAT
PROFINET
380~480VAC
0.28~5.03kW
i=3~100

ME&AN
永磁同步伺服马
达&伺服驱动器
Permanent
Magnet
Servo Motor
& Servo Drive

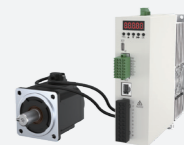

EtherCAT/
PROFINET
200~240VAC
0.1kW~1.2kW

博能传动(沈阳)有限公司	BONENG TRANSMISSION(SHENYANG)CO.,LTD.
辽宁省沈阳市沈北新区 太平洋工业城A区A73-6号 电话: 024-31271571	No. A73-6, Area A, Pacific Industrial City, Shenbei New District, Shenyang, Liaoning Province, China TEL: 024-31271571
博能传动(天津)有限公司	BONENG TRANSMISSION(TIANJIN)CO.,LTD.
天津市北辰区双海道6号 宏鹏工业园7号车间 电话: 022-26929556	7th Workshop, Hongpeng Industrial Park, No. 6 Shuanghai Road, Beichen District, Tianjin City,China TEL: 022-26929556
博能传动(潍坊)有限公司	BONENG TRANSMISSION(WEIFANG)CO.,LTD.
山东省潍坊市安丘市经济开发区 汶水路与昆仑大街交叉口往北 100米路东1号车间 电话: 0536-2141166	1st Workshop, Economic Development Zone, Anqiu, Weifang City, Shandong Province, China TEL: 0536-2141166
博能传动(开封)有限公司	BONENG TRANSMISSION(KAIFENG)CO.,LTD.
河南省开封市宋城路四大街11号 海神机械院内五号厂房 电话: 0371-23335238	5th Workshop, Haishen Machinery, No.11, Fourth Street, Songcheng Road,New District, Kaifeng City, Henan Province, China TEL: 0371-23335238
博能传动(长沙)有限公司	BONENG TRANSMISSION(CHANGSHA)CO.,LTD.
湖南省长沙市望城经济开发区 普瑞大道1288号 电话: 0731-88386958	No. 1288 Puri Avenue, Wangcheng Economic Development Zone, Changsha City, Hunan Province, China TEL: 0731-88386958
博能传动设备(成都)有限公司	BONENG TRANSMISSION EQUIPMENT(CHENGDU) CO., LTD.
四川省成都市金牛区金牛坝路9号5栋 向荣中心A座7楼-703 电话: 028-87741100	703, 7th Floor, Block A, Xiangrong Center, Building 5, No. 9 Jinniuba Road, Jinniu District, Chengdu City, Sichuan Province, China TEL: 028-87741100
博能传动(肇庆)有限公司	BONENG TRANSMISSION(ZHAOQING)CO.,LTD.
广东省肇庆市鼎湖区肇庆新区 科创大道7号平谦国际现代产业园 一期A12北厂房 电话: 0757-86719757	No. 7 Science and Technology Innovation Avenue, Zhaoqing New Area, Dinghu District, Zhaoqing City, Guangdong Province, China TEL: 0757-86719757
博能传动(苏州)有限公司	BONENG TRANSMISSION(SUZHOU)CO.,LTD.
江苏省苏州市相城区如元路100号 电话: 0512-66189662	No. 100, Ruyuan Road, Xiangcheng District, Suzhou, Jiangsu Province, China TEL: 0512-66189662

博能传动(美国)有限公司	BONENG TRANSMISSION(USA)LLC.
1250 E 222nd Euclid, OH 44117, United Staes TEL: 1-216-618-0138 TEL: 1-216-618-0496 TEL: 1-216-618-3099	1250 E 222nd Euclid, OH 44117, United Staes TEL: 1-216-618-0138 TEL: 1-216-618-0496 TEL: 1-216-618-3099
博能传动(印度)有限公司	BONENG TRANSMISSION(INDIA)PVT.LTD
Plot No. E-10/3, MIDC sinnar (Malegaon) Industrial Area, Nashik, 422123, Maharashtra, India. TEL:+91-11- 4507 6293 (DELHI) TEL:+91-22-2781 3385 (MUMBAI)	Plot No. E-10/3, MIDC sinnar (Malegaon) Industrial Area, Nashik, 422123, Maharashtra, India. TEL:+91-11- 4507 6293 (DELHI) TEL:+91-22-2781 3385 (MUMBAI)