

R系列蜗轮减速机

R Worm Gear Units

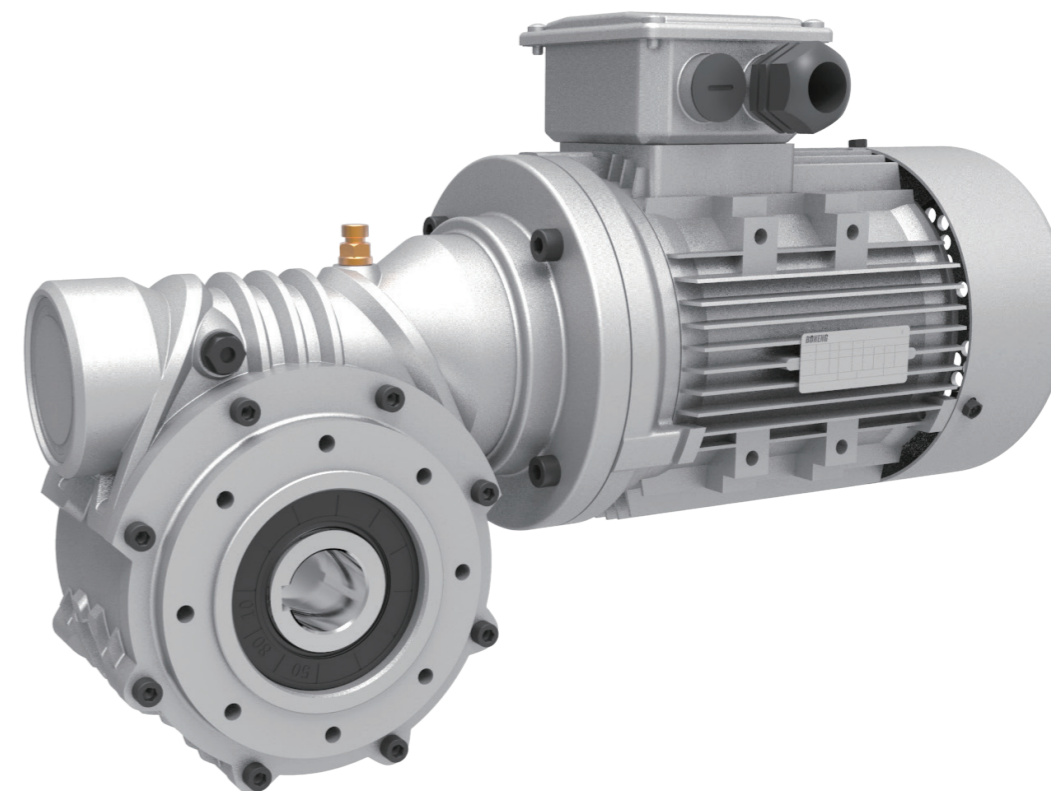

R系列蜗轮
减速机

R Worm
Gear Units

Modified date 04/2026
Selection Sample C05.0003



控制器/驱动器/马达/
齿轮马达/齿轮箱

Controller/ Drive/ Motor/
Gearmotor/ Gearbox

蜗轮减速机

博能公司在总结二十余年齿轮箱设计制造经验，分析和吸收国际上减速电机设计制造的先进技术的基础上，创新发展，推出新型R系列减速电机，以更好满足客户要求。

同国际上先进的减速电机和博能公司原有R系列减速电机相比，博能公司新型R系列减速电机具有：

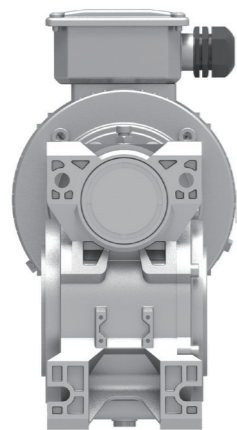

Worm Gear Units

On the basis of summarizing gear units design and manufacturing experiences in the past twenty years, analyzing and absorbing advanced technology of international gear units motor production, Boneng Transmission makes innovative development, pushing forward new type R series gear motor to better satisfy customer requirements.

Compared with internationally advanced gear motor and the original R series gear motor of Boneng, the new type R series gear motor has the following characteristics:

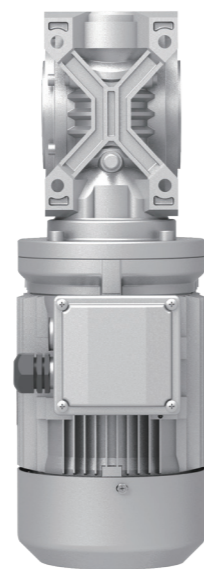

- ◆ 独创的模块化设计，零部件通用最大化，便于国际化生产，库存少，供货周期短。
- ◆ 独创的模块化设计，功能附件的配置互换程度高，能灵活满足客户设备要求的各种结构及布置形式和不同的使用工况。
- ◆ 同向轴输出，蜗轮箱可串联使用，减少动力源。
- ◆ 采用德国进口蜗轮滚刀加工，优化蜗轮齿面接触区，传动精度高，承载能力大。
- ◆ 通过拟生态的外观设计，赋予产品运动和力量的天性内涵，体现了博能公司世界级的卓越产品设计理念，并拥有自主知识产权。
- ◆ 能以单级传动获得较大的传动比，且传动平稳，振动、冲击和噪音均小。
- ◆ 拥有底脚式、法兰式、轴装式等多种安装方式，能满足客户的不同安装方式要求。
- ◆ 蜗轮材质为锡青铜，蜗杆为合金钢经渗碳淬火后精密磨削；具有良好的抗胶合和耐磨的性能，使用寿命长。
- ◆ 氟橡胶密封件，具有优异的耐高温、防老化、耐磨损性能，在复杂和恶劣的工作环境中具有更高的安全性和更长的使用寿命。
- ◆ Unique modular design, general applications of components are maximized, which is convenient for international production, storage quantity is small, supplement circle is short.
- ◆ Unique modular design, allocation exchange degree of functional attachments flexibly satisfy various kinds of required structures, arrangement form and different working situations of customer equipment.
- ◆ Homodromous shaft output, worm box can be used together, thus reduce driving source.
- ◆ It applies Germany imported worm hob processing, which optimize worm gear face contact region. The transmission accuracy is high, bearing capacity is large.
- ◆ The appearance design shows world-wise product design idea of Boneng transmission, it owns intellectual property rights.
- ◆ It can get large transmission ratio with single level transmission, the transmission is stable, it owns foot mounting, flange mount, shaft mount, shaft mounting and various kinds of mounting methods, Vibration, impact and noise are low.
- ◆ It owns foot mounting, flange mounting, shaft mounting and various kinds of mounting methods, which can satisfy various kinds of mounting requirements of customers.
- ◆ The material of worm is tin bronze, the worm rod is alloy steel, which is grinded after carburizing and quenching; the material has good anti-gluing and anti-abrasion performances, the lifespan is long.
- ◆ Fluorous rubber sealing piece, with good high-temperature resistant, anti-aging and anti-abrasion performance, it is safer and with longer lifespan in complex and bad working environment.

目录

Contents

注意事项:

- ◆ 样本中的结构示意图、外形图及其他附图只属范例。无严格比例要求。(未注尺寸单位均为mm)。
- ◆ 所注重量仅为平均值,并不具有约束力。

⚠️ 必须严格遵守以下各项:

- ◆ 为防止意外事故发生,所有旋转部件均按照使用者所在国家和地区的安全规范由购置方加罩保护。
- ◆ 试车之前必须认真阅读使用说明书。
- ◆ 升降机在供货时已处于准运行状态,运行前需加注润滑油。
- ◆ 本样本中注油量只作为参考值,实际注油量应以油尺上的标记为准。
- ◆ 润滑油粘度应按升降机使用工况及使用环境温度选取。
- ◆ 只能采用国际知名品牌的润滑油。

产品功能标识



油 镜



通 气 帽



进 油 孔



放 油 孔

Note:

- ◆ The structure scheme, appearance diagram and other attached diagrams in sample are examples, there is no strict proportion requirement.(The unmarked dimension units are mm).
- ◆ We can only refer to the marked weight in the manual.

⚠️ You must conform to the following instructions:

- ◆ To prevent accidents,all the rotation parts should be added with protective covers according to local safety regulations and laws.
- ◆ Before testing,users should read instruction manual carefully.
- ◆ Jack has been tested before delivered,users should add lubrication oil before running.
- ◆ We can only refer to the marked oil in the manual.Actual oil filling level should be the same with the mark on oil immersion lens.
- ◆ Lubrication oil viscosity should be selected according to working conditions and the temperature of local environment.
- ◆ Users can only use high quality lubrication oil.

Product Function Mark



Oil glass

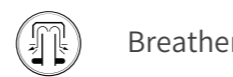

Breather

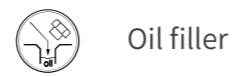

Oil filler

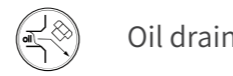

Oil drain

01.型号表示方法	01	01.Type Designation	02
02.选型及举例	05	02.Type Selection and Example	05
03.传动能力表	09	03.Transmission Capacity	09
04.直联电机功率表	11	04.Directly connected motor power table	11
05.允许径向力Fr2(N)	12	05.Permissible Radial Force on Shaft (Fr2) (N)	12
06.外形尺寸图表	13	06.Outline Dimension Diagram	13
07.电机尺寸图	21	07.Motor Dimension Diagram	21
08.轴输入及同向输出轴尺寸	23	08.Shaft input and homodromous shaft dimension	23
09.输入法兰与轴孔尺寸	24	09. Dimensions of Input Flange and Shaft Bore	24
10.组合型	25	10.Combined type	25
11.润滑油	26	11.Lubrication oil	26

1 型号表示方法

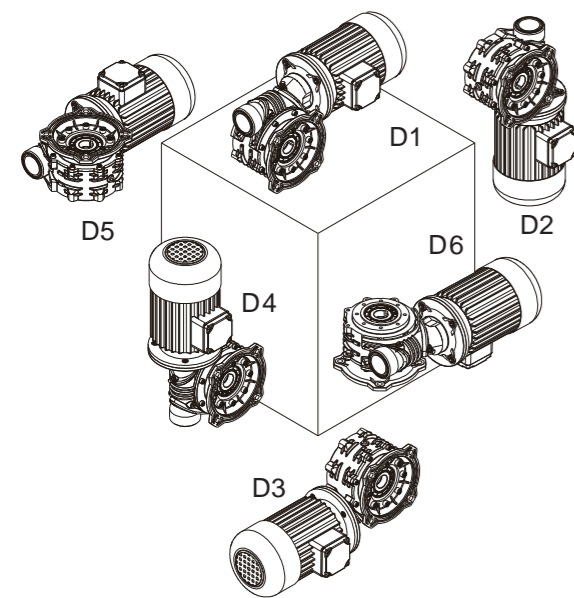
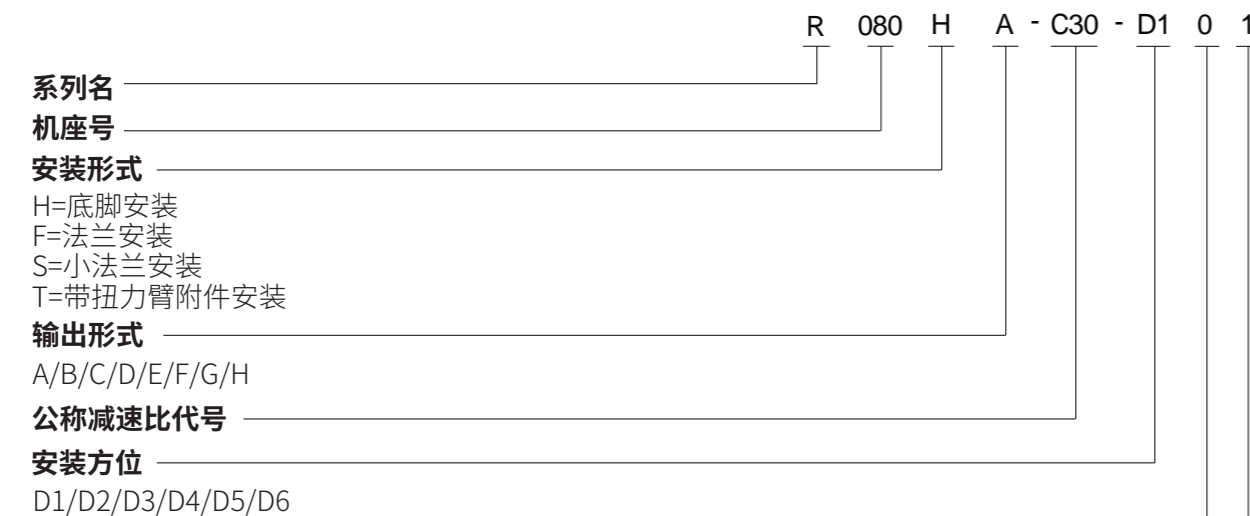

可选附件和指定配置

0=不带同向输出轴
1=带同向输出轴

润滑油代号

0=不加润滑油 (R050~R080出厂已加入000#极压锂基润滑脂, 以及其他不加油出厂时, 请选此项)
4=矿物润滑油VG680 (环境温度 $-20^{\circ}\text{C}\sim+40^{\circ}\text{C}$, 需加油出厂时, 请选此项)
5=合成润滑油 (环境温度 $<0^{\circ}\text{C}$, 需加油出厂时, 推荐选用此项)

◆配输入轴型号示例:R080HA-C30-D100-S

◆配法兰输入型号示例:R080HA-C30-D100-AF71

◆组合型号示例:R080FA/R050-D35-D100-MP071M4A25SL1-A0N00-011-ZR01¹⁾

注1):ZR01为组合布置形式可查询25页组合型尺寸及布置形式

MP090S4B11SL 1 - A 0 N 0 0 - 0 1 1

进线孔位置 1/2/3/4
接线盒位置 1/2/3/4
马达安装方位0

马达防护
0=标准配置 (IP55/F) 1=带防雨罩 J=带金属接头;
K=带金属接头和防雨罩 4=IP65/金属接头 5=IP65/金属接头和带防雨罩

热保护和加热保护
0=无绕组保护 1=热敏电阻 2=热敏开关 3=温度传感器PT100 4=加热带
5=热敏电阻和加热带 6=热敏开关和加热带 7=温度传感器PT100和加热带

制动器

N=无制动器	G=带自锁制动器220-240VAC	P=双制动器220-240VAC
A=制动器220-240VAC	H=带自锁制动器380-415VAC	Q=双制动器380-415VAC
B=制动器380-415VAC	J=带自锁制动器440-480VAC	X=双制动器440-480VAC
C=制动器440-480VAC	K=带微动开关制动器220-240VAC	R=带手柄双制动器220-240VAC
D=带手柄制动器220-240VAC	L=带微动开关制动器380-415VAC	S=带手柄双制动器380-415VAC
E=带手柄制动器380-415VAC	M=带微动开关制动器440-480VAC	T=带手柄双制动器440-480VAC
F=带手柄制动器440-480VAC		

编码器
0=无编码器 1=高性能HTL编码器(1024P) 2=标配编码器附件
4=高性能TTL编码器(1024P) 3=经济型HTL编码器(1024P)

冷却方式
A=自扇冷却; F=强冷风机; (编码器必选;其他不建议选)

频率电压

1=50Hz 220V Δ /380VY	5=60Hz 440V Δ	E=60Hz 220V Δ /380VY;
2=50Hz 230V Δ /400VY	6=60Hz 460V Δ	F=60Hz 380V Δ ;
3=50Hz 380V Δ /660VY	7=60Hz 440VY	
4=50Hz 400V Δ /690VY	8=60Hz 460VY	
A=50Hz 240V Δ /415VY	C=60Hz 480VY	
B=50Hz 415V Δ	D=60Hz 480V Δ	

注:3KW及以下“Y”接法, 可选代号1,2,7,8,A,C,E;
4KW及以上“ Δ ”接法, 可选代号3,4,5,6,B,D,F.

三相异步马达4极规格

马达接线盒和进线孔位置 (视角:D1方位马达尾部)

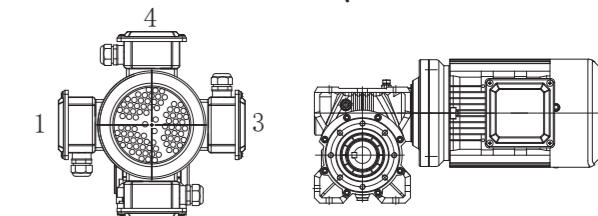

整机标配颜色:
R050-R080: (RAL9006)
R100-R250: (RAL5015)
非标配颜色可按客户要求定制。

马达系列/机座号/极数/功率代号/安装形式/基座材质									
规格	R050	R063	R080	R100	规格	R125	R160	R200	R250
0.12KW	MP063M4A12FL MU063M4A12FL	MP063M4A12FL MU063M4A12FL			1.1KW	MP090S4B11FL MU090L4B11FL			
0.18KW	MP063M4A18FL MU063M4A18FL	MP063M4A18FL MU063M4A18FL			1.5KW	MP090M4B15FL MU100L4B15SL			
0.25KW	MP071M4A25SL MU071M4A25SL	MP071M4A25SL MU071M4A25SL	MP071M4A25FL MU071M4A25FL		2.2KW	MP100M4B22SL MU100L4B22SL	MP100M4B22FL MU100L4B22FL		
0.37KW	MP071M4A37SL MU080M4A37SL	MP071M4A37SL MU080M4A37SL	MP071M4A37FL MU080M4A37FL		3KW	MP100M4B30SL MU112M4B30SC	MP100M4B30FL MU112M4B30FC		
0.55KW	MP080M4A55SL MU080M4A55SL	MP080M4A55SL MU080M4A55SL	MP080M4A55FL MU080M4A55FL	MP080M4A55SL MU080M4A55SL	4KW	MP112L4B40SC MU132S4B40SC	MP112L4B40FC MU132S4B40FC		
0.75KW	MP080M4A75SL MU090S4A75AL	MP080M4A75SL MU090S4A75SL	MP080M4A75FL MU090S4A75SL	MP080M4A75SL MU090S4A75SL	5.5KW	MP132M4B55SC MU132M4B55SC	MP132M4B55FC MU132M4B55FC	MP132M4B55FC MU132M4B55FC	
1.1KW		MP090S4B11SL MU090L4B11SL	MP090S4B11SL MU090L4B11SL	MP090S4B11SL MU090L4B11SL	7.5KW	MP132L4B75SC MU160M4B75AC	MP132L4B75FC MU160M4B75FC	MP132L4B75FC MU160M4B75FC	
1.5KW		MP090M4B15SL MU100L4B15AL	MP090M4B15SL MU100L4B15SL	MP090M4B15SL MU100L4B15SL	11KW	MP160M4C11AC MU160L4C11AC	MP160M4C11FC MU160L4C11FC	MP160M4C11FC MU160L4C11FC	MP160M4C11FC MU160L4C11FC
2.2KW			MP100M4B22SL MU100L4B22SL	MP100M4B22SL MU100L4B22SL	15KW		MP160L4C15FC MU180M4C15FC	MP160L4C15FC MU180M4C15FC	MP160L4C15FC MU180M4C15FC
3KW			MP100M4B30SL MU112M4B30SC	MP100M4B30SL MU112M4B30SC	18.5KW			MP180M4C18FC MU180L4C18FC	MP180M4C18FC MU180L4C18FC
4(KW)			MP112L4B40SC MU132S4B40AC	MP112L4B40SC MU132M4B40AC	22KW			MP180L4C22FC MU200L4C22FC	MP180L4C22FC MU200L4C22FC
5.5KW				MP132M4B55AC MU132M4B55AC	30KW				MP200M4C30FC
7.5KW				MP160M4B75AC MU160M4B75AC					

1 Type Designation

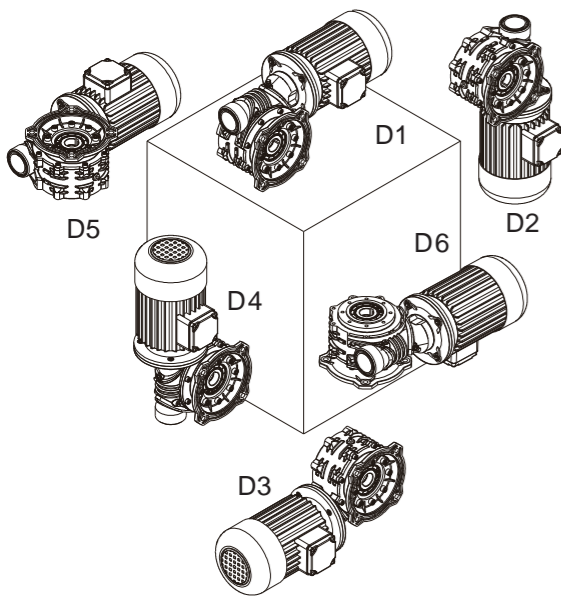
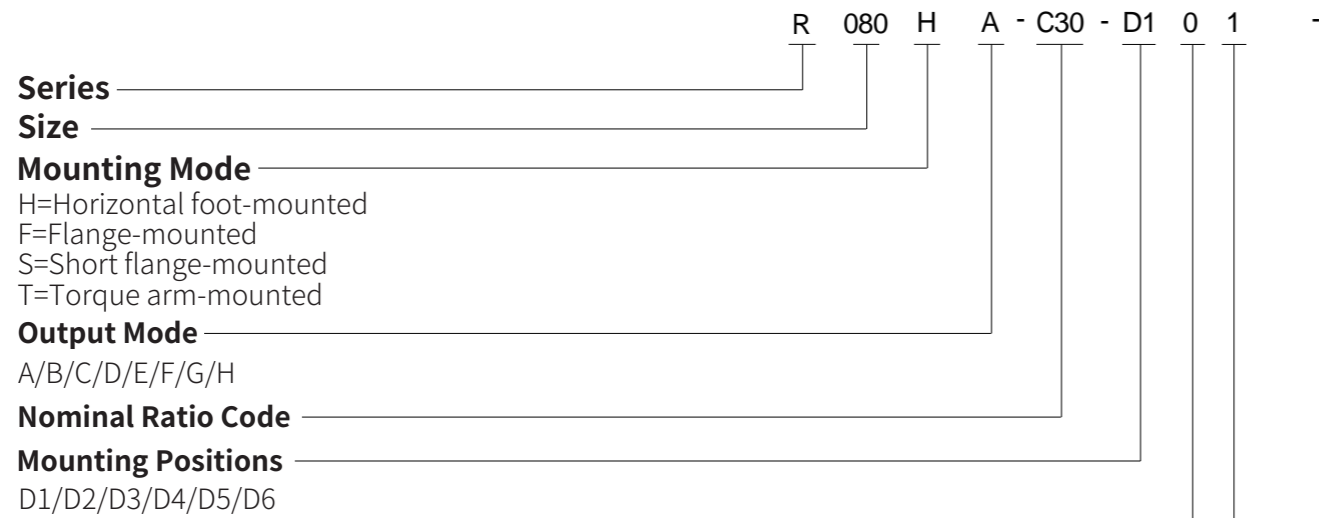

Accessories and Specific Configuration

0=without homodromous shaft
1=homodromous shaft

Oil Code

0=Without oil filling(Please select this option when you do not need lubricating oil or R050~R080 factory with 000# extreme pressure lithium-based grease added);
4=With mineral oil of VG680(Please select this option when the ambient temperature is -20°C~+40°C
5=With synthetic lubricating oil VG220(It is recommended to select this option when you need lubricating oil and the ambient temperature is below 0°C);

- ◆Example of matching input shaft model:R080HA-C30-D100-S
 - ◆Example of flange input model:R080HA-C30-D100-AF71
 - ◆Example of combined model:R080FA/R050-D35-D100-MP071M4A25SL1-A0N00-011-ZR01¹⁾
- Note 1): ZR01 is a combined layout type; you can refer to page 25 for the dimensions and layout forms of the combined type.

Motor terminal box and cable entry position (View: Motor afterbody in D1 position)

MP090S4B11SL 1 - A 0 N 0 0 - 0 1 1

Cable Entry Position 1/2/3/4

Terminal Box Position 1/2/3/4

Motor Mounting Position 0

Standard colour of the machine:
R050-R080: (RAL9006)
R100-R250: (RAL5015)
Non-standard colour can be customized according to customer requirements.

Motor protection
0=Standard configuration(IP55/F) K=With metal joint and rain cover
1=With rain cover 4=IP65/with metal joint
J=With metal joint 5=IP65/with metal joint and rain cover

Thermal Protection and Heating Protection
0=Without themal protection 3= PT100 temperature sensor 6=Thermal switch and heating belt
1=Thermistor 4=Heating belt 7= PT100 temperature sensor and heating belt
2=Thermal switch 5=Thermistor and heating belt and heating protection

Brakes

N=No brake	G=With self-locking brake 220-240VAC	P=Double brake 220-240VAC
A=Brake 220-240VAC	H=With self-locking brake 380-415VAC	Q=Double brake 380-415VAC
B=Brake 380-415VAC	J=With self-locking brake 440-480VAC	X=Double brake 440-480VAC
C=Brake 440-480VAC	K=Brake with release handle 220-240VAC	R=Double brake with release handle 220-240VAC
D=Brake with release handle 220-240VAC	L=Brake with micro switch 380-415VAC	S=Double brake with release handle 380-415VAC
E=Brake with release handle 380-415VAC	M=Brake with micro switch 440-480VAC	T=Double brake with release handle 440-480VAC
F=Brake with release handle 440-480VAC		

Encoder
0=No encoder 1=High-performance HTL encoder(1024P) 2=Standard encoder accessories
4=High-performance TTL encoder(1024P) 3=Economic HTL encoder(1024P)

Cooling Method
A=Self-fan cooling F=Forced-fan cooling

Frequency Voltage

1=50Hz 220V△/380VY	5=60Hz 440V△	E=60Hz 220V△/380VY;
2=50Hz 230V△/400VY	6=60Hz 460V△	F=60Hz 380V△;
3=50Hz 380V△/660VY	7=60Hz 440VY	
4=50Hz 400V△/690VY	8=60Hz 460VY	
A=50Hz 240V△/415VY	C=60Hz 480VY	
B=50Hz 415V△	D=60Hz 480V△	

Note:Alternative code of 3KW and below:1,2,7,8,A,C,E
Alternative code of 4KW and above:3,4,5,6,B,D,F

Efficiency three-phase asynchronous motor (4 pole)

Motor Series / Frame Number / Number of Poles / Power Code / Mounting Type / Base Material											
Size	R050	R063	R080	R100	Size	R125	R160	R200	R250		
0.12KW	MP063M4A12FL MU063M4A12FL	MP063M4A12FL MU063M4A12FL			1.1KW	MP090S4B11FL MU090L4B11FL					
0.18KW	MP063M4A18FL MU063M4A18FL	MP063M4A18FL MU063M4A18FL			1.5KW	MP090M4B15FL MU100L4B15SL					
0.25KW	MP071M4A25SL MU071M4A25SL	MP071M4A25SL MU071M4A25SL	MP071M4A25FL MU071M4A25FL		2.2KW	MP100M4B22SL MU100L4B22SL	MP100M4B22FL MU100L4B22FL				
0.37KW	MP071M4A37SL MU080M4A37SL	MP071M4A37SL MU080M4A37SL	MP071M4A37FL MU080M4A37FL		3KW	MP100M4B30SL MU112M4B30SC	MP100M4B30FL MU112M4B30FC				
0.55KW	MP080M4A55SL MU080M4A55SL	MP080M4A55SL MU080M4A55SL	MP080M4A55FL MU080M4A55FL	MP080M4A55SL MU080M4A55SL	4KW	MP112L4B40SC MU132S4B40SC	MP112L4B40FC MU132S4B40FC				
0.75KW	MP080M4A75SL MU090S4A75AL	MP080M4A75SL MU090S4A75SL	MP080M4A75FL MU090S4A75FL	MP080M4A75SL MU090S4A75SL	5.5KW	MP132M4B55SC MU132M4B55SC	MP132M4B55FC MU132M4B55FC	MP132M4B55FC MU132M4B55FC			
1.1KW	MP090S4B11SL MU090L4B11SL	MP090S4B11SL MU090L4B11SL	MP090S4B11FL MU090L4B11FL	MP090S4B11SL MU090L4B11SL	7.5KW	MP132L4B75SC MU160M4B75AC	MP132L4B75FC MU160M4B75FC	MP132L4B75FC MU160M4B75FC			
1.5KW	MP090M4B15SL MU100L4B15AL	MP090M4B15SL MU100L4B15SL	MP090M4B15FL MU100L4B15FL	MP090M4B15SL MU100L4B15SL	11KW	MP160M4C11AC MU160L4C11AC	MP160M4C11FC MU160L4C11FC	MP160M4C11FC MU160L4C11FC	MP160M4C11FC MU160L4C11FC		
2.2KW			MP100M4B22SL MU100L4B22SL	MP100M4B22SL MU100L4B22SL	15KW		MP160L4C15FC MU180M4C15FC	MP160L4C15FC MU180M4C15FC	MP160L4C15FC MU180M4C15FC		
3KW			MP100M4B30SL MU112M4B30SC	MP100M4B30SL MU112M4B30SC	18.5KW			MP180M4C18FC MU180L4C18FC	MP180M4C18FC MU180L4C18FC		
4(KW)			MP112L4B40SC MU132S4B40AC	MP112L4B40SC MU132M4B40AC	22KW			MP180L4C22FC MU200L4C22AC	MP180L4C22FC MU200L4C22FC		
5.5KW				MP132M4B55AC MU132M4B55AC	30KW				MP200M4C30FC		
7.5KW				MP132L4B75AC MU160M4B75AC							

2 选型及举例

2 Type Selection and Example

序号	说明	代号	参数计算									
Serial number	Instruction	Codes	Parameters Calculation									
1	被驱动设备系数 Driven Machine Factor	f1	负荷性质 Load Characteristic	每天使用时间 (小时) Operating hours per day (h)								
				≤2	2~10	10~24						
			均匀负载 Uniform	1.00 (1.00)	1.00 (1.25)	1.25 (1.50)						
			一般冲击 Moderate	1.00 (1.25)	1.25 (1.50)	1.50 (1.75)						
			强烈冲击 Heavy	1.25 (1.50)	1.50 (1.75)	1.75 (2.00)						
注: 当每小时启动、停止次数 ≥ 10次, 请使用括号内数值。 Note: Apply values in the brackets when starting and stopping time per hour are less than 10 times												
2	环境温度系数 Ambient temperature factor	ft	负荷性质 Load Characteristic	环境温度 Ambient temperature								
				20	25	30	35	40	45	50		
			均匀负载 Uniform	1.00	1.00	1.00	1.03	1.06	1.12	1.20		
			一般冲击 Moderate	1.00	1.01	1.02	1.06	1.12	1.16	1.30		
强烈冲击 Heavy	1.00	1.02	1.04	1.10	1.17	1.20	1.40					
3	输入转速 Input speed	n1	≤1800r/min 更高转速请咨询 ≤1800r/min Consult us if higher speed required.									
4	确定减速比 Calculation of the ratio	i	$i=n1/n2$									
5	传动效率 Transmission efficiency	η	见05页 (传动能力表) See the table of transmission capacity on P05									
6	以被动设备所需的扭矩或功率, 确定齿轮马达的输入功率 Calculation of the input power of the gearmotor on basis of the torque and power required by the driven machine.	P1	$P1=T2 \cdot n1 / (9550 \cdot i \cdot \eta)$ 或 $P1=P2 / \eta$									
7	根据计算, 查传动能力表, 确定齿轮马达规格, 直联马达时需查直联马达功率表 Determination of gearmotor type referring to the table of transmission capacity after calculation, For directly-connected motor, require to refer to directly connected motor power table.	T2N、P1N	$T2N \geq T2 \cdot f1 \cdot ft$ 或 $P1N \geq P1 \cdot f1 \cdot ft$									

序号	说明	代号	参数计算	
Serial number	Instruction	Codes	Parameters Calculation	
8	径向力、轴向力校核 Check the radial and axial forces on the shafts	Fr1/Fr2 Fa1/Fa2	见08页, R系列 Fr2表。 See Fr2 table on P08	
9	确认润滑方式 Determination of lubrication system		一般采用飞溅润滑 (R50~R80脂润滑) Generally Apply Splash Lubrication	
10	确认冷却方式 Determination of cooling system		自然冷却 Natural Cooling	
11	按型号表示方法确定各项 Determination of every item included in the type designation		型号表示方法见第03页 For details about type designation, see P03.	
12	一般环境条件 Normal ambient conditions		环境温度: -10至40℃, 空旷场地通风良好, 海拔高度1000米一下, 一般工厂灰尘。 环境温度: -10至40℃, 空旷场地通风良好, 海拔高度1000米一下, 一般工厂灰尘。	
13	特殊环境条件 Special ambient conditions		高温、低温、灰尘多、化学作用(例: 酸碱等), 露天(直接日照、冰、水淋等), 请咨询。 For higher or lower temperature, dusty sites, chemical reaction (acids, alkaline, etc), or open field (sunlight, ice, rain, etc), please consult us!	

选型举例	Examples of type selection
<p>1) 减速电机</p> <p>已知条件:</p> <p>1 被驱动设备所需功率P2=5kW 所需转速n2=95 r/min; 2 普通电机: 4极, 转速n1=1450r/min; 3 负荷性质: 一般冲击, 工作12小时/天, 启动频率1次/小时, 环境温度20℃; 4 安装输出形式: 单向实心输出轴与法兰同向, 法兰安装, 安装方位D4, 接线盒位置180°</p> <p>选型步骤:</p> <p>1、根据负荷性质表可得出被驱动设备系数f1=1.5, ft=1; 2、确定速比iN: i= n1/n2=1450/95=15.3, 取公称减速比iN=15;</p>	<p>1) Gear motor</p> <p>Known Criteria:</p> <p>1. The power required by the driven machine P2=5kW, speed needed n2=95r/min 2. Common motor: 4-pole, speed n1=1450r/min 3. Loading characteristics: moderate impact, working 12 hours/d and starting frequency 1 time/h, ambient temperature 20 °C 4. Mounting output mode: Unidirectional solid output shaft on the same side with flange, flange-mounted, mounting position D4, terminal box position 180°</p> <p>Selection Steps:</p> <p>1. By referring to the table of Loading Characteristic, we get the driven machine factor f1=1.5, and ft=1 2. Calculation of the ratio: As i=n1/n2=1450/95=15.3, nominal ratio iN=15 is appropriate</p>

选型举例	Examples of type selection
<p>3、计算输入功率并确定电机功率(查得蜗轮箱传动效率 $\eta=84\%$): $P_1=P_2/\eta=5/0.84=5.95\text{kW}$, 取电机功率7.5kW;</p> <p>4、确定减速电机额定功率P_{1N}:$P_{1N}\geq P_1 \cdot f_1 \cdot f_t=5.95 \times 1.5 \times 1=8.925\text{ kW}$;</p> <p>5、根据已知条件和以上数据, 根据传动能力表可初选减速机, 电机型号为: R125FA-C15-D101-MP132L4B75SC3-AON00-111</p> <p>2) 齿轮箱</p> <p>已知条件:</p> <ol style="list-style-type: none"> 1、被驱动设备所需扭矩$T_2=75\text{N} \cdot \text{m}$, 所需转速$n_2=73\text{r}/\text{min}$; 2、用户自配电机的要求: 4极, 转速$n_1=1450\text{r}/\text{min}$; 3、负荷性质: 一般冲击, 工作16小时/天, 连续运转, 环境温度20°C; 4、安装输出形式: 平键空心轴输出, 底脚安装, 安装方位D1。 <p>选型步骤:</p> <ol style="list-style-type: none"> 1、根据负荷性质查表可得出被驱动设备系数$f_1=1.5$, $f_t=1$; 2、确定速比i_N: $i_N=n_1/n_2=1450/73=19.86$, 取公称减速比$i_N=20$; 3、确定减速箱额定扭矩$T_{2N}$及额定功率$P_{1N}$ (查表得出蜗轮箱传动效率 $\eta=81\%$): $T_{2N}\geq T_2 \cdot f_1 \cdot f_t=75 \times 1.5=112.5\text{ N} \cdot \text{m}$; $P_{1N}\geq P_1 \cdot f_1 \cdot f_t=T_2 \cdot f_1 \cdot f_t \cdot n_1/(9550 \cdot i_N \cdot \eta)$ $=75 \times 1.5 \times 1 \times 1450/(9550 \times 20 \times 0.81)$ $=1.05\text{kW}$; 根据传动能力表可得出R63满足要求($T_{2N}=116\text{N} \cdot \text{m}$, $P_{1N}=1.12\text{ kW}$); 4、确定输入部分: 根据 $P_{1N}\geq P_1\geq T_2 \cdot n_1/(9550 \cdot i_N \cdot \eta)$ $=75 \times 1450/(9550 \times 20 \times 0.81)$ $=0.7\text{kW}$; 用户自配的电机功率取$P_1=0.75\text{ kW}$, 查14页 输入法兰与轴孔尺寸选AF80即可; 5、根据已知条件和以上数据, 可初选出减速机型号为: R063HG-C20-D101-AF80 	<p>3. Calculation of the input power and determination of the motor power (transmission efficiency of worm box $\eta=84\%$): $P_1=P_2/n=5/0.84=5.95\text{kW}$, so 7.5kW motor is selected.</p> <p>4. Determination of the rated power of the gear motor P_{1N}: $P_{1N}>P_1 \cdot f_1 \cdot f_t=5.95 \times 1.5 \times 1=8.925\text{kW}$</p> <p>5. The type selected according to the table of transmission capacity, known conditions and the above data: R125FA-C15-D101-MP132L4B75SC3-AON00-111</p> <p>2) Gear Unit</p> <p>Known Criteria:</p> <ol style="list-style-type: none"> 1. The torque required by the driven machine $T_2=75\text{N} \cdot \text{m}$ and speed required $n_2=73\text{r}/\text{min}$ 2. The requirement of the motor supplied by the users:4-pole, speed $n_1=1450\text{r}/\text{min}$ 3. Loading characteristic:moderate impact, operating 16h/d,Continuous running,environment temperature 20°C 4. Mounting output mode:hollow output shaft with parallel key,foot-mounted, mounting position D1 <p>Selection steps:</p> <ol style="list-style-type: none"> 1. By referring to the table of loading Characteristic,we get the driven machine factor $f_1=1.5$, and $f_t=1$. 2. Calculation of the ratio i_N: As $i_N=n_1/n_2=1450/73=19.86$, nominal ratio $i_N=20$ is appropriate 3. Determination of the nominal torque T_{2N} and rated power P_{1N} of the gear unit (transmission efficiency of worm box $\eta=81\%$): $T_{2N}>T_2 \cdot f_1 \cdot f_t=75 \times 1.5=112.5\text{ N} \cdot \text{m}$; $P_{1N}>P_1 \cdot f_1 \cdot f_t=T_2 \cdot f_1 \cdot f_t \cdot n_1/(9550 \cdot i_N \cdot \eta)$ $=175 \times 1.5 \times 1 \times 1450/(9550 \times 20 \times 0.81)$ $=1.05\text{kW}$ In the table of Transmission Capacity,R63 meets the requirements ($T_{2N}=116\text{N} \cdot \text{m}$, $P_{1N}=1.12\text{ kW}$) 4. Determination of the input part: As $P_{1N}>P_1\geq T_2 \cdot n_1/(9550 \cdot i_N \cdot \eta)$ $=75 \times 1450/(9550 \times 20 \times 0.81)$ $=0.7\text{kW}$ and power of the user-supplied motor is specified as 0.75kW, in the table of dimensions of input flange and shaft bore on P14, Af80 is selected. 5. The type is selected according to known criteria and data R063HG-C20-D101-AF80

3 传动能力表

3.1 基本型

3 Transmission Capacity

3.1 Basic type

n ₁ (r/min)	Code	i _N	η	R050				R063				R080				R100			
				n _{2N} (r/min)	T _{2N} (N·m)	i _{ex}	P _{1N}	n _{2N} (r/min)	T _{2N} (N·m)	i _{ex}	P _{1N}	n _{2N} (r/min)	T _{2N} (N·m)	i _{ex}	P _{1N}	n _{2N} (r/min)	T _{2N} (N·m)	i _{ex}	P _{1N}
1450	B70	7	0.87	220	37	6.60	0.98	234	69	6.2	1.94	177	230	8.2	4.90	250	315	5.8	9.5
	C10	10	0.84	136	57	10.7	0.97	140	110	10.3	1.92	136	255	10.7	4.32	136	465	10.7	7.9
	C15	15	0.84	101	62	14.3	0.78	98.9	114	14.7	1.40	101	235	14.3	2.96	101	450	14.3	5.7
	C20	20	0.81	77.7	69	18.7	0.69	75.0	116	19.3	1.12	73.7	230	19.7	2.19	77.7	430	18.7	4.32
	C30	30	0.79	45.3	80	32	0.48	46.8	131	31	0.81	45.3	270	32	1.62	45.3	555	32	3.33
	C45	45	0.75	32.2	62	45	0.28	33.7	106	43	0.50	33.7	235	43	1.11	33.0	435	44	2.00
	C60	60	0.71	25.4	53	57	0.20	23.8	103	61	0.36	25.0	215	58	0.79	25.4	405	57	1.52

R125				R160				R200				R250			
n _{2N} (r/min)	T _{2N} (N·m)	i _{ex}	P _{1N}	n _{2N} (r/min)	T _{2N} (N·m)	i _{ex}	P _{1N}	n _{2N} (r/min)	T _{2N} (N·m)	i _{ex}	P _{1N}	n _{2N} (r/min)	T _{2N} (N·m)	i _{ex}	P _{1N}
186	650	7.8	14.5	/	/	/	/	/	/	/	/	/	/	/	/
136	720	10.7	12.2	/	/	/	/	/	/	/	/	/	/	/	/
98.9	745	14.7	9.2	98.9	1500	14.7	18.5	101	2500	14.3	31.5	98.9	3950	14.7	48.7
77.7	715	18.7	7.2	/	/	/	/	/	/	/	/	/	/	/	/
45.3	835	32	5.0	43.9	1600	33	9.3	42.6	3050	34	17.2	43.9	5000	33	29.1
33.0	765	44	3.52	32.2	1550	45	7.0	33.0	2900	44	13.3	32.2	5050	45	22.7
25.4	685	57	2.57	25.0	1450	58	5.3	/	/	/	/	/	/	/	/

3.2 R../R..组合型

3.2 R../R..Combined type

n ₁ (r/min)	n _{2N} (r/min)	Code	i _N	η	R050./R050			R063./R050			R080./R050		
					T _{2N} (N·m)	i _{ex}	P _{1N}	T _{2N} (N·m)	i _{ex}	P _{1N}	T _{2N} (N·m)	i _{ex}	P _{1N}
1450	14.5	D10	100	0.55	78	94.6	0.23	141	96.8	0.40	230	94.6	0.67
	9.06	D16	160	0.54	78	152.9	0.14	141	156.4	0.25	230	152.9	0.42
	7.25	D20	200	0.52	78	205.4	0.11	141	210.2	0.20	230	205.4	0.33
	4.08	D35	355	0.48	111	341.3	0.10	188	330.7	0.18	325	341.3	0.30
	3.22	D45	450	0.45	111	458.7	0.08	188	444.3	0.14	325	458.7	0.24
	2.30	D63	630	0.40	111	597.3	0.07	188	578.7	0.12	325	597.3	0.21
	1.45	E10	1000	0.35	111	1024	0.05	188	992.0	0.08	325	1024	0.14
	1.04	E14	1400	0.30	122	1440	0.04	205	1376	0.08	355	1376	0.13
	0.73	E20	2000	0.30	122	2025	0.03	205	1935	0.05	355	1935	0.09
	0.58	E25	2500	0.24	122	2565	0.03	205	2745	0.05	355	2610	0.09

R100./R050			R125./R063			R160./R080			R200./R100			R250./R125		
T _{2N} (N·m)	i _{ex}	P _{1N}	T _{2N} (N·m)	i _{ex}	P _{1N}	T _{2N} (N·m)	i _{ex}	P _{1N}	T _{2N} (N·m)	i _{ex}	P _{1N}	T _{2N} (N·m)	i _{ex}	P _{1N}
405	94.6	1.18	1200	90.9	3.64	2300	120.3	5.3	4350	83.1	14.4	6700	114.4	16.2
405	152.9	0.74	1300	151.6	2.28	2450	156.4	4.40	4500	152.9	8.3	7200	156.4	12.9
405	205.4	0.58	1450	215.1	2.12	2800	210.2	3.89	5200	205.4	7.4	8000	215.1	10.9
570	341.3	0.53	1500	330.7	1.34	2950	352.0	2.65	5500	362.7	4.80	8500	352	7.6
570	458.7	0.42	1650	469.3	1.24	3200	473.0	2.28	6000	487.3	4.15	9100	484	6.3
570	597.3	0.36	1650	618.7	0.99	3200	649.0	1.87	6000	634.7	3.59	9100	616	5.6
570	1024	0.24	1650	992.0	0.72	3200	1056	1.31	6000	1088	2.39	9100	1056	3.74
570	1408	0.20	1650	1364	0.60	3200	1440	1.12	6000	1408	2.16	9100	1440	3.20
625	1980	0.16	1650	1892	0.42	3200	1935	0.84	6000	1936	1.57	9100	1980	2.33
625	2565	0.15	1650	2451	0.42	3200	2494	0.81	6000	2508	1.51	9100	2565	2.24

3.3 R../C..组合型

3.3 R../C..Combined type

iN:100-710

n ₁ (r/min)	N _{2n} (r/min)	Code	i _N	η	R125/C04				R160/C06				R200/C07				R250/C08							
					T _{2N} (N·m)	Ci _{ex}	Rvi _{ex}	i _{ex}	P _{1N} (KW)	T _{2N} (N·m)	Ci _{ex}	Rvi _{ex}	i _{ex}	P _{1N} (KW)	T _{2N} (N·m)	Ci _{ex}	Rvi _{ex}	i _{ex}	P _{1N} (KW)	T _{2N} (N·m)	Ci _{ex}	Rvi _{ex}	i _{ex}	P _{1N} (KW)
1450	14.5	D10	100	0.72	1200	6.70	14.667	98.3	2.58	2300	7.33	14.667	107.5	4.51	4350	7.14	14.333	102.3	9.0	6700	7.27	14.667	106.6	13.3
	12.9	D11	112	0.70	1200	7.37	14.667	108.1	2.41	2300	7.82	14.667	114.7	4.35	4350	8.13	14.333	116.5	8.1	6700	7.97	14.667	116.9	12.4
	11.6	D12	125	0.70	1300	8.20	14.667	120.3	2.34	2450	8.59	14.667	126.0	4.22	4500	9.01	14.333	129.1	7.6	7200	9.20	14.667	134.9	11.6
	9.06	D16	160	0.66	1400	11.5	14.667	168.7	1.91	2650	10.5	14.667	154.0	3.96	4900	11.6	14.333	166.3	6.8	7500	11.3	14.667	165.7	10.4
	8.06	D18	180	0.66	1400	13.2	14.667	193.6	1.66	2650	12.5	14.667	183.3	3.33	4900	12.6	14.333	180.6	6.2	7500	12.7	14.667	186.3	9.3
	6.47	D22	224	0.66	1450	7.37	32	235.8	1.41	2800	7.33	33	241.9	2.66	5200	6.34	34	215.6	5.5	8000	7.27	33	239.9	7.7
	5.80	D25	250	0.66	1450	8.20	32	262.4	1.27	2800	7.82	33	258.1	2.50	5200	7.14	34	242.8	4.93	8000	7.97	33	263.0	7.0
	5.18	D28	280	0.66	1500	9.21	32	294.7	1.17	2950	8.59	33	283.5	2.39	5600	8.13	34	276.4	4.66	8500	9.20	33	303.6	6.4
	4.08	D35	355	0.65	1600	11.5	32	368.0	1.02	3050	10.5	33	346.5	2.06	5800	10.3	34	350.2	3.87	8800	10.4	33	343.2	6.0
	3.63	D40	400	0.64	1600	13.2	32	422.4	0.90	3050	12.5	33	412.5	1.75	5800	11.6	34	394.4	3.49	8800	12.7	33	419.1	5.0
	3.22	D45	450	0.64	1600	14.5	32	464.0	0.82	3050	13.9	33	458.7	1.58	5800	12.6	34	428.4	3.21	8800	13.9	33	458.7	4.55
	3.02	D48	480	0.63	1650	16.4	32	524.8	0.76	3200	15.3	33	504.9	1.53	6000	14.5	34	493.0	2.93	9100	16.1	33	531.3	4.13
	2.59	D56	560	0.62	1650	17.5	32	560.0	0.72	3200	17.4	33	574.2	1.36	6000	15.4	34	523.6	2.81	9100	17.2	33	567.6	3.93
	2.42	D60	600	0.62	1650	13.2	44	580.8	0.70	3200	19.0	33	627.0	1.25	6000	17.7	34	601.8	2.44	9100	12.7	45	571.5	3.90
	2.30	D63	630	0.62	1650	14.5	44	638.0	0.63	3200	13.9	45	625.5	1.25	6000	14.5	44	638.0	2.30	9100	13.9	45	625.5	3.56
	2.04	D71	710	0.60	1650	16.4	44	721.6	0.58	3200	15.3	45	688.5	1.18	6000	15.4	44	677.6	2.24	9100	16.1	45	724.5	3.18

iN:800-5000

n ₁ (r/min)	N _{2n} (r/min)	Code	i _N	η	R125/C04				R160/C06				R200/C07				R250/C08			
					T _{2N} (N·m)	Ci _{ex}	Rvi _{ex}	i _{ex}	P _{1N} (KW)	T _{2N} (N·m)	Ci _{ex}	Rvi _{ex}	i _{ex}	P _{1N} (KW)	T _{2N} (N·m)	Ci _{ex}	Rvi _{ex}	i _{ex}	P _{1N} (KW)	T _{2N} (N·m)
1450	1.81	D80	800	0.60	1650	19.3	44	849.2	0.49	3200	19.0	45	855.0	0.95	6000	17.7	44	778.8	1.95	9100

4 直联电机功率表

4 Directly connected motor power table

		R50直联电机功率表 R50 Directly connected motor power table								R63直联电机功率表 R63 Directly connected motor power table													
iN	Pm(kW)	0.12	0.18	0.25	0.37	0.55	0.75	1.1	1.5	2.2	3	4	0.12	0.18	0.25	0.37	0.55	0.75	1.1	1.5	2.2	3	4
7																							
10																							
15																							
20																							
30																							
45																							
60																							

		R80直联电机功率表 R80 Directly connected motor power table								R100直联电机功率表 R100 Directly connected motor power table													
iN	Pm(kW)	0.25	0.37	0.55	0.75	1.1	1.5	2.2	3	4	5.5	7.5	0.55	0.75	1.1	1.5	2.2	3	4	5.5	7.5	11	14
7																							
10																							
15																							
20																							
30																							
45																							
60																							

		R125直联电机功率表 R125 Directly connected motor power table								R160直联电机功率表 R160 Directly connected motor power table													
iN	Pm(kW)	0.75	1.1	1.5	2.2	3	4	5.5	7.5	11	15	18.5	1.1	1.5	2.2	3	4	5.5	7.5	11	15	18.5	22
7																							
10																							
15																							
20																							
30																							
45																							
60																							

		R200直联电机功率表 R200 Directly connected motor power table								R250直联电机功率表 R250 Directly connected motor power table													
iN	Pm(kW)	3	4	5.5	7.5	11	15	18.5	22	30	37	45	7.5	11	15	18.5	22	30	37	45	55	75	90
7																							
10																							
15																							
20																							
30																							
45																							
60																							

- | | |
|---|--|
| 1. 符号表示可直联电机; | 1. Symbol means it can be connected with motor directly |
| 2. 符号表示可直联电机 (电机功率大于减速机的额定输入功率, 即P1>P1N) ; | 2. Symbol means it can be connected with motor directly (motor power larger than rated input power of gear unit, that is P>PiN) |
| 3. 符号表示不可直联电机; | 3. Symbol means it can't be connected with motor that is. |
| 4. 电机功率的选择应符合相应的被驱动设备系数及选型规定; | 4. The selection of motor power should conform to relevant driven equipment coefficient and selection regulation. |
| 5. 电机为4极电机。 | 5. The motor is 4-pole motor |

5 允许径向力Fr2(N)

5 Permissible Radial Force on Shaft (Fr2)(N)

R50~80系列输出轴径向力Fr2表

R50~80Series Output Shaft Radial force Fr2 Table

n _{2N} (r/min)		Fr ₂ (N)		
输出转速范围 output speed range		R50	R63	R80
200	315	560	810	/
180	200	940	1250	1810
160	180	985	1280	2000
125	160	1120	1550	2280
100	125	1200	1680	2400
90	100	1300	1930	2930
80	90	1430	2000	3200
63	80	1530	2180	3410
50	63	1690	2400	3800
40	50	1740	2650	4060
31.5	40	1970	2940	4670
25	31.5	2180	3220	5250
20	25	2480	3360	5250
≤20		2520	3760	5250

R100~250系列输出轴径向力Fr2表

R100~250Series Output Shaft Radial force Fr2 Table

n _{2N} (r/min)		Fr ₂ (N)				
输出转速范围 output speed range		R100	R125	R160	R200	R250
160	250	1340	1230	/	/	/
100	160	2160	2920	8120	/	/
80	100	2790	3780	9990	19500	30320
63	80	3340	4640	11310	21300	33890
50	63	3610	5160	/	/	/
40	50	3880	5400	13730	25200	40600
31.5	40	4560	6360	14700	25200	44040
25	31.5	4920	6960	14700	25200	47000
20	25	5540	7350	14700	25200	47000
≤20		6300	7350	/	/	/

6 外形尺寸图表

6 Outline Dimension Diagram

安装形式 Mounting Mode	R050
底脚安装 Horizontal foot-mounted	<p>重量: 3KG (不含马达和润滑油) Weight: 3KG (without motor and oil)</p> <p>R050HA R050HB R050HC</p> <p>R050HG R050HH</p> <p>空心输出轴尺寸 Hollow output shaft dimension</p>
法兰安装 Flange-mounted	<p>重量: 3KG (不含马达和润滑油) Weight: 3KG (without motor and oil)</p> <p>R050FA R050FB R050FC</p> <p>R050FD R050FE R050FF</p> <p>R050FG R050FH</p> <p>空心输出轴尺寸 Hollow output shaft dimension</p>
小法兰安装 Short flange-mounted	<p>重量: 2.8KG (不含马达和润滑油) Weight: 2.8KG (without motor and oil)</p> <p>R050SA R050SB R050SC</p> <p>R050SG R050SH</p> <p>空心输出轴尺寸 Hollow output shaft dimension</p>
带扭力臂 附件安装 Torque arm-mounted	<p>重量: 3.47KG (不含马达和润滑油) Weight: 3.47KG (without motor and oil)</p> <p>R050TG R050TH</p> <p>空心输出轴尺寸 Hollow output shaft dimension</p>

安装形式 Mounting Mode	R063
底脚安装 Horizontal foot-mounted	<p>重量: 5.4KG (不含马达和润滑油) Weight: 5.4KG (without motor and oil)</p> <p>R063HA R063HB R063HC</p> <p>R063HG R063HH</p> <p>空心输出轴尺寸 Hollow output shaft dimension</p>
法兰安装 Flange-mounted	<p>重量: 5.41KG (不含马达和润滑油) Weight: 5.41KG (without motor and oil)</p> <p>R063FA R063FB R063FC</p> <p>R063FD R063FE R063FF</p> <p>R063FG R063FH</p> <p>空心输出轴尺寸 Hollow output shaft dimension</p>
小法兰安装 Short flange-mounted	<p>重量: 5.08KG (不含马达和润滑油) Weight: 5.08KG (without motor and oil)</p> <p>R063SA R063SB R063SC</p> <p>R063SG R063SH</p> <p>空心输出轴尺寸 Hollow output shaft dimension</p>
带扭力臂 附件安装 Torque arm-mounted	<p>重量: 5.8KG (不含马达和润滑油) Weight: 5.8KG (without motor and oil)</p> <p>R063TG R063TH</p> <p>空心输出轴尺寸 Hollow output shaft dimension</p>

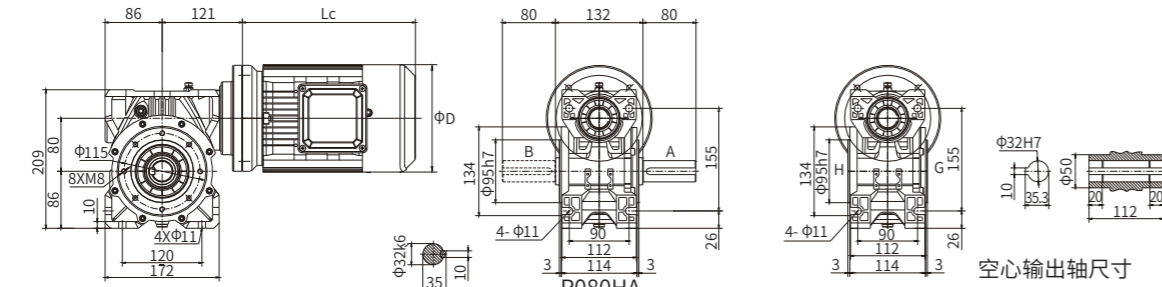
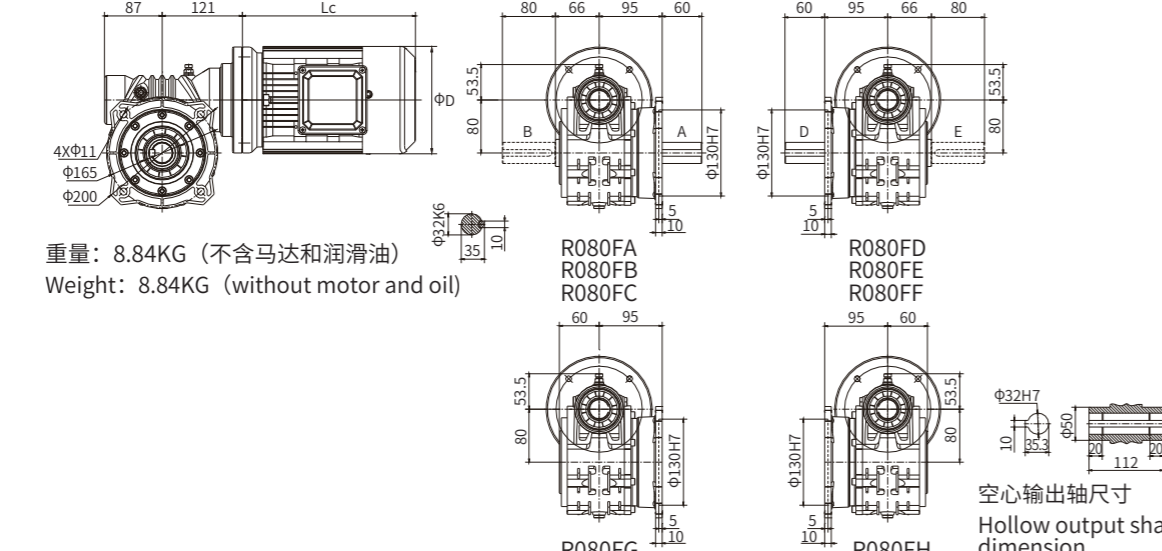
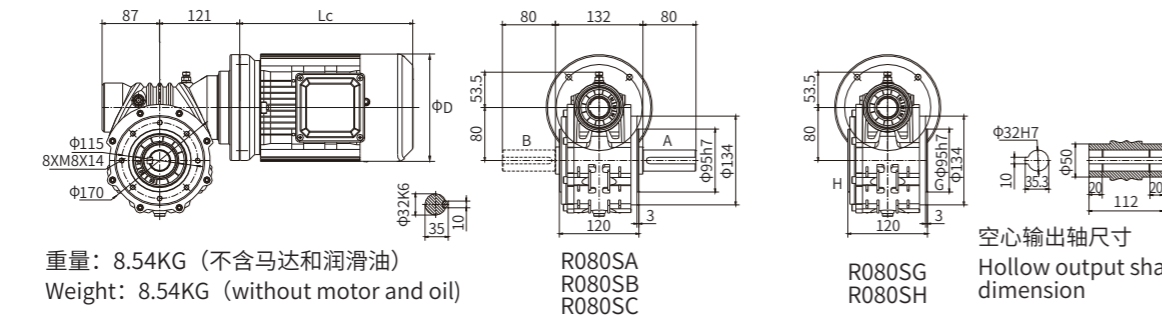
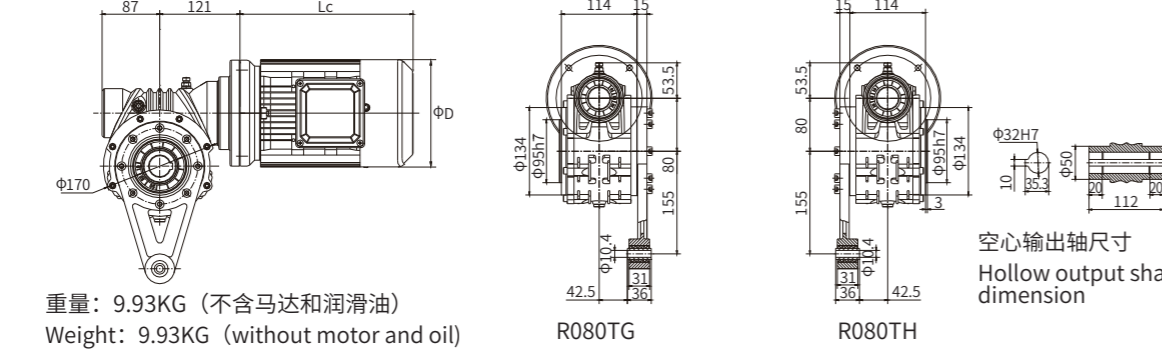
安装形式 Mounting Mode	R80		
底脚安装 Horizontal foot-mounted	 <p>重量: 8.8KG (不含马达和润滑油) Weight: 8.8KG (without motor and oil)</p> <p>空心输出轴尺寸 Hollow output shaft dimension</p>		
法兰安装 Flange-mounted	 <p>重量: 8.84KG (不含马达和润滑油) Weight: 8.84KG (without motor and oil)</p> <p>空心输出轴尺寸 Hollow output shaft dimension</p>		
小法兰安装 Short flange-mounted	 <p>重量: 8.54KG (不含马达和润滑油) Weight: 8.54KG (without motor and oil)</p> <p>空心输出轴尺寸 Hollow output shaft dimension</p>		
带扭力臂 附件安装 Torque arm-mounted	 <p>重量: 9.93KG (不含马达和润滑油) Weight: 9.93KG (without motor and oil)</p> <p>空心输出轴尺寸 Hollow output shaft dimension</p>		

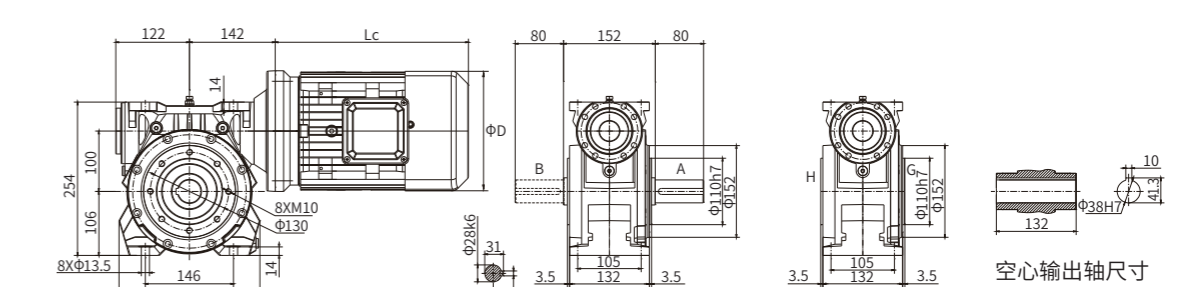
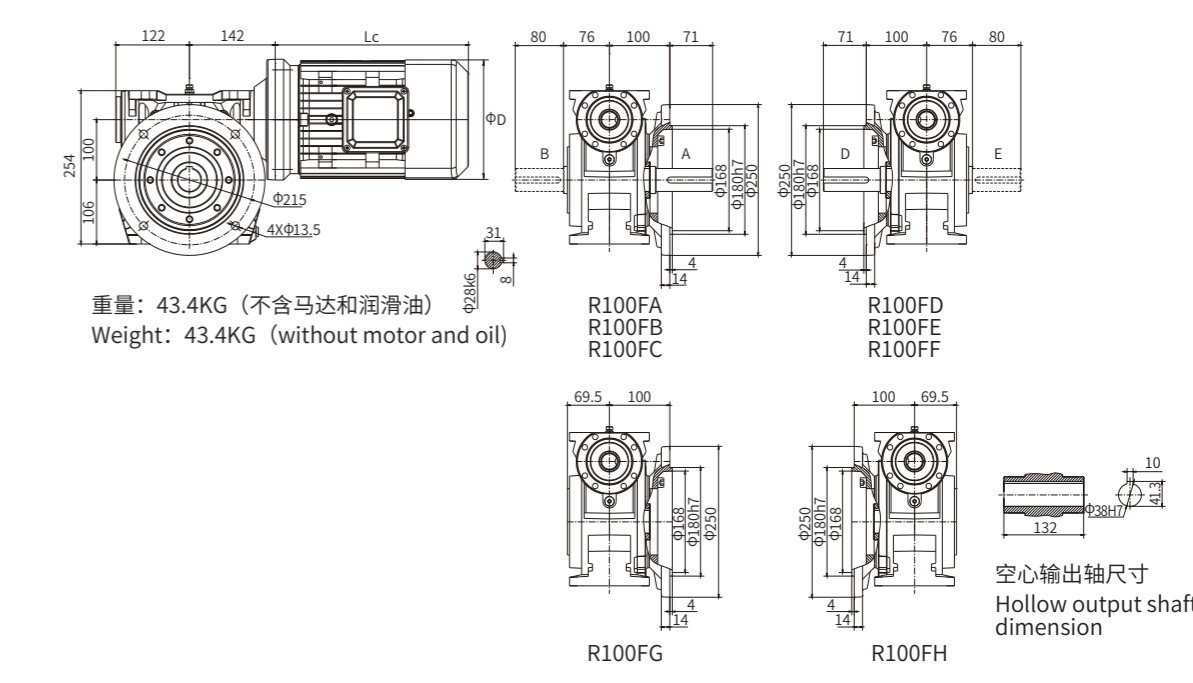
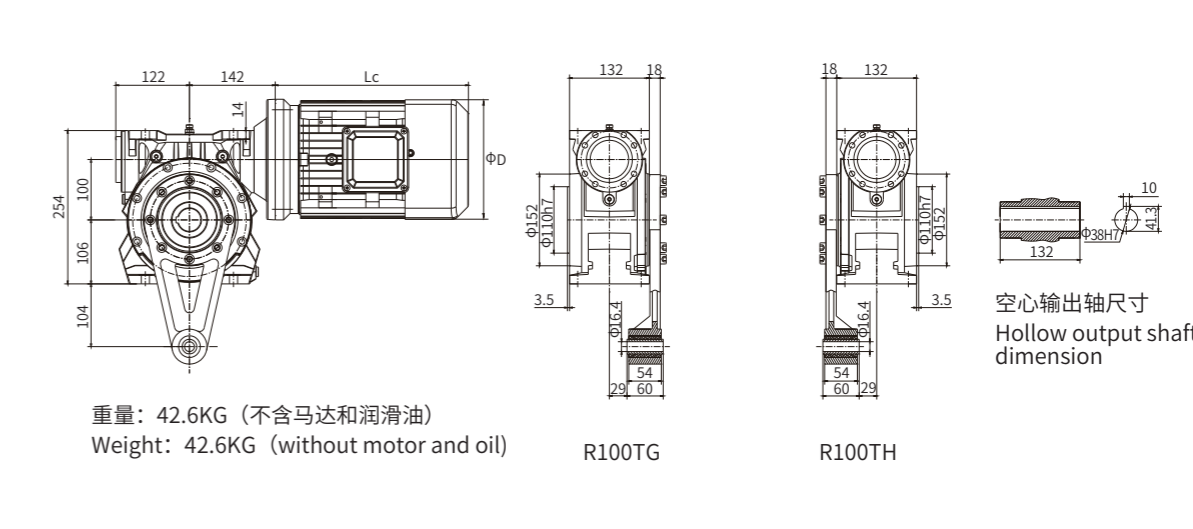
安装形式 Mounting Mode	R100		
底脚安装 Horizontal foot-mounted	 <p>重量: 40KG (不含马达和润滑油) Weight: 40KG (without motor and oil)</p> <p>空心输出轴尺寸 Hollow output shaft dimension</p>		
法兰安装 Flange-mounted	 <p>重量: 43.4KG (不含马达和润滑油) Weight: 43.4KG (without motor and oil)</p> <p>空心输出轴尺寸 Hollow output shaft dimension</p>		
带扭力臂 附件安装 Torque arm-mounted	 <p>重量: 42.6KG (不含马达和润滑油) Weight: 42.6KG (without motor and oil)</p> <p>空心输出轴尺寸 Hollow output shaft dimension</p>		

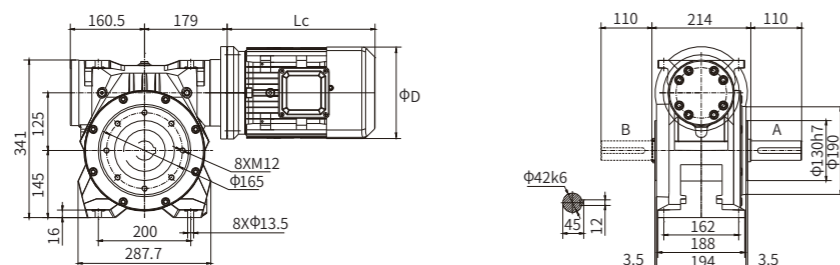
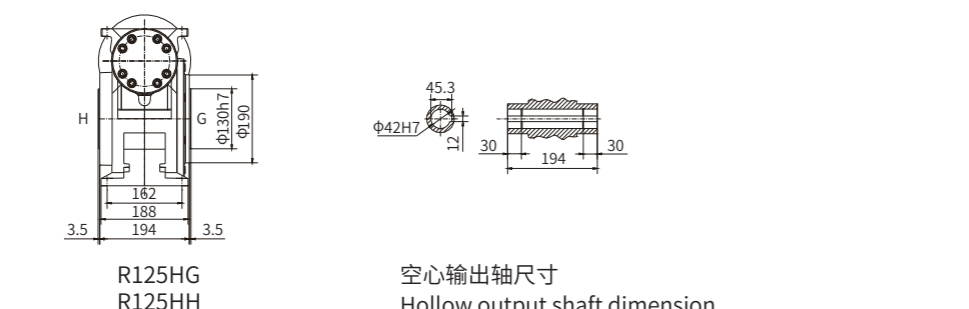
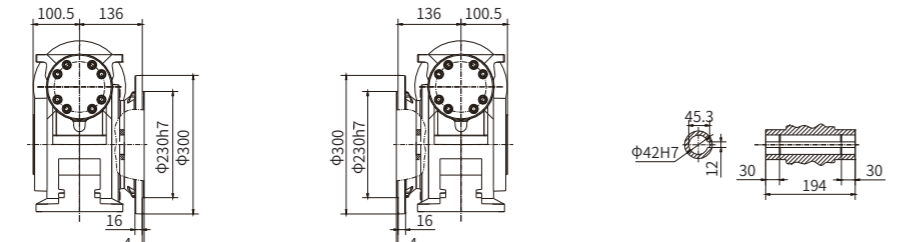
安装形式 Mounting Mode	R125
底脚安装 Horizontal foot-mounted	 <p>重量: 80KG (不含马达和润滑油) Weight: 80KG (without motor and oil)</p> <p>R125HA R125HB R125HC</p>
法兰安装 Flange-mounted	 <p>重量: 87.4KG (不含马达和润滑油) Weight: 87.4KG (without motor and oil)</p> <p>R125FA R125FB R125FC</p> <p>R125FD R125FE R125FF</p> <p>空心输出轴尺寸 Hollow output shaft dimension</p>  <p>R125FG</p> <p>R125FH</p> <p>空心输出轴尺寸 Hollow output shaft dimension</p>

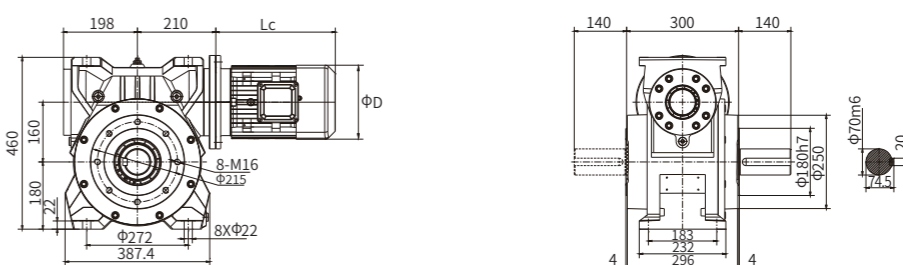
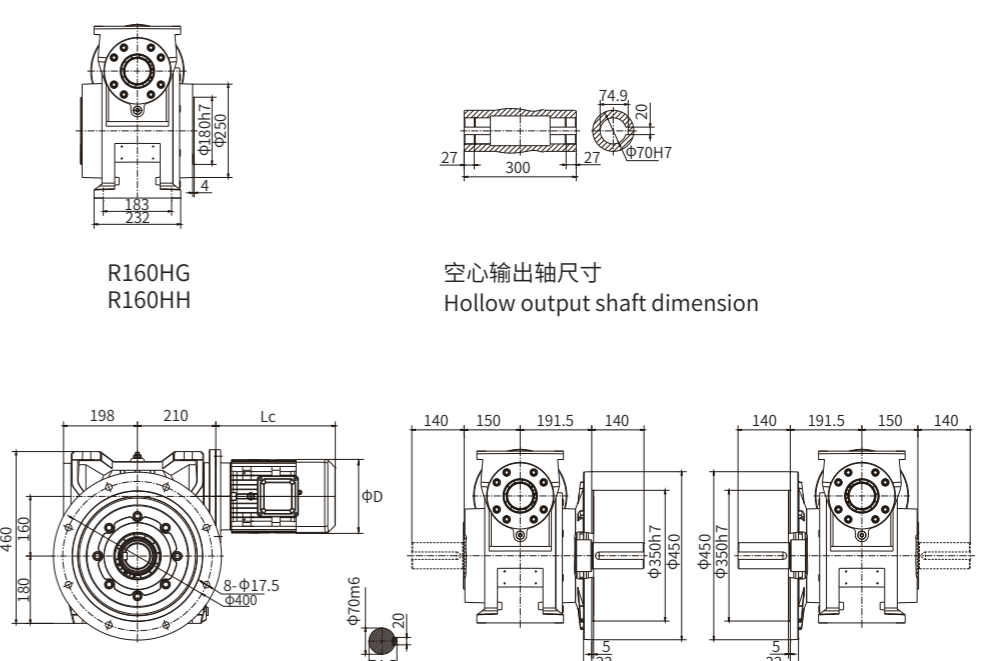
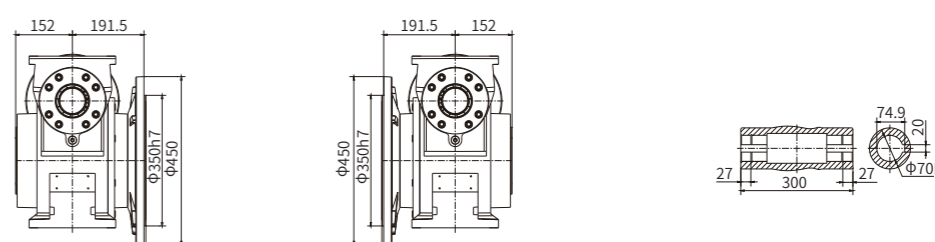
安装形式 Mounting Mode	R160
底脚安装 Horizontal foot-mounted	 <p>重量: 150KG (不含马达和润滑油) Weight: 150KG (without motor and oil)</p> <p>R160HA R160HB R160HC</p>
法兰安装 Flange-mounted	 <p>重量: 170.6KG (不含马达和润滑油) Weight: 170.6KG (without motor and oil)</p> <p>R160FA R160FB R160FC</p> <p>R160FD R160FE R160FF</p> <p>空心输出轴尺寸 Hollow output shaft dimension</p>  <p>R160FG</p> <p>R160FH</p> <p>空心输出轴尺寸 Hollow output shaft dimension</p>

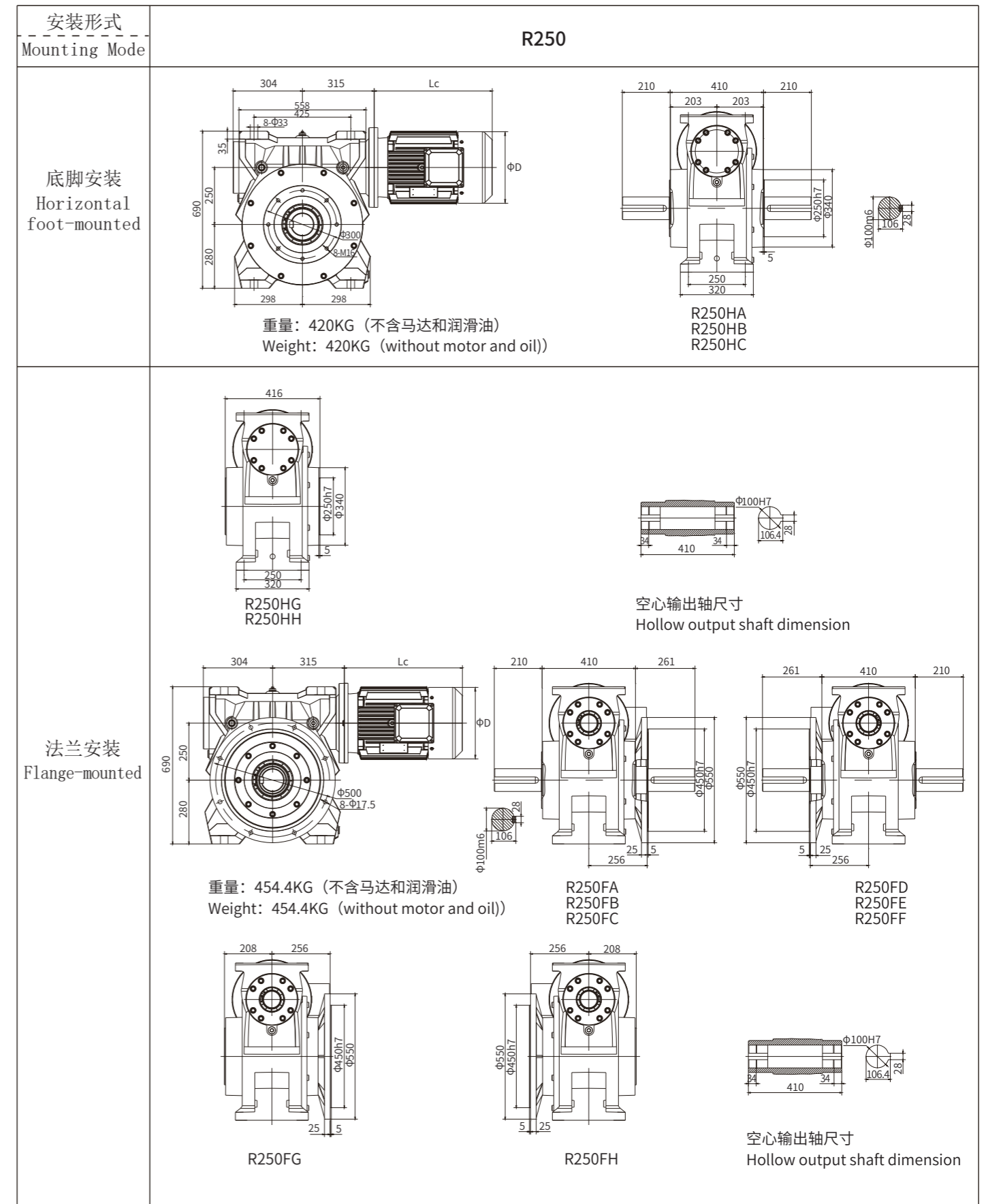
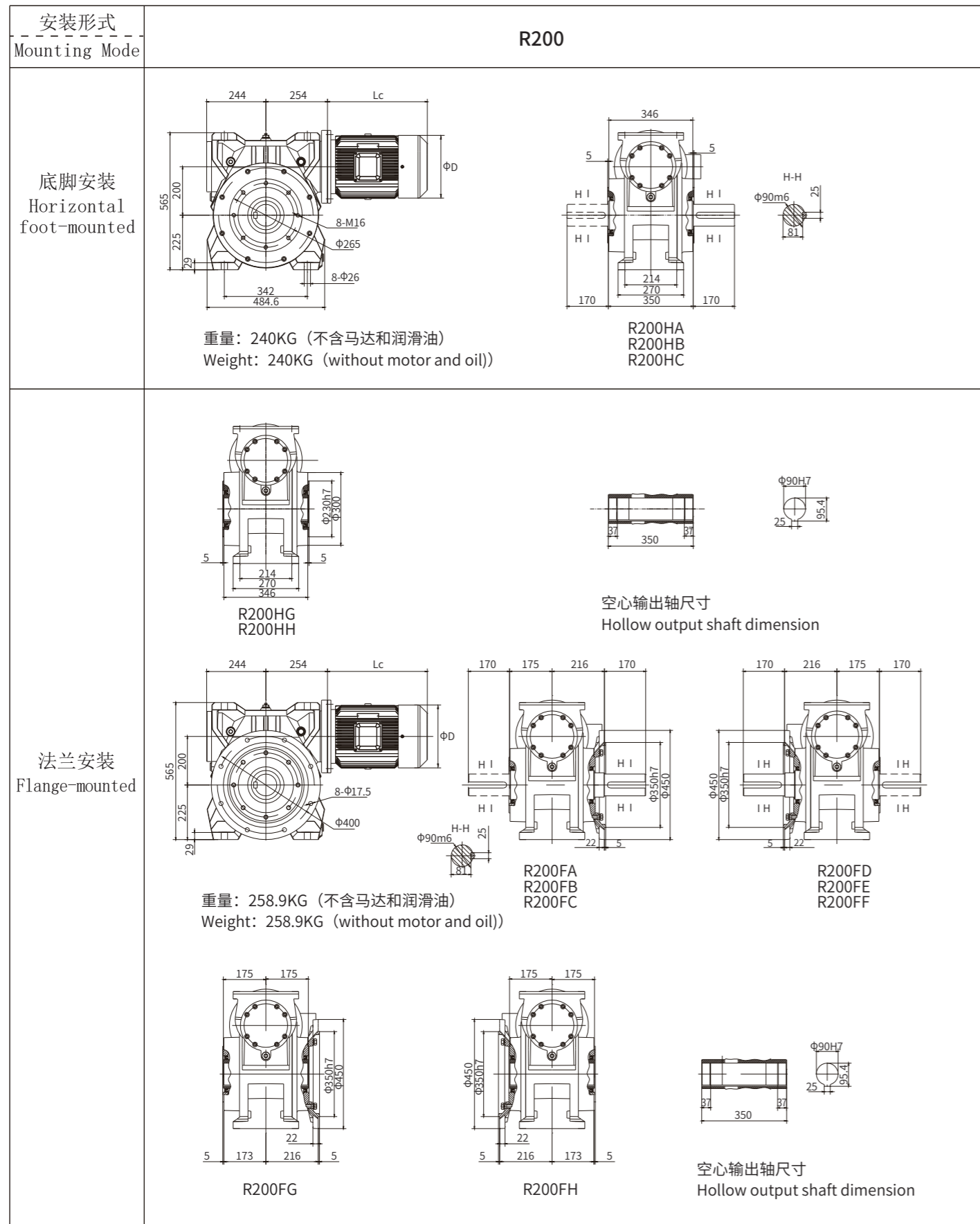

7 电机尺寸图

7.1 直连MP电机尺寸图:

7 Motor Dimension Diagram

7.1 Dimensions for Directly-connected Motor MP:

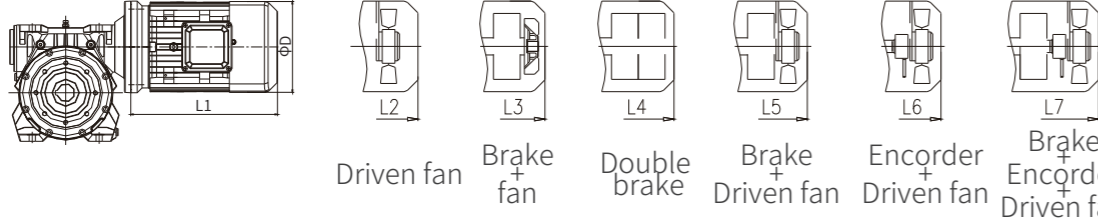

Size	P1/KW	iN	L1	L2	L3	L5	L6	L7	D
R050	0.12	7-60	192	247	227	282	/	/	124
	0.18	7-60	192	247	227	282	/	/	124
	0.25	7-60	214	259	254	309	309	349	139
	0.37	7-60	214	259	254	309	309	349	139
	0.55	7-20	261	306	321	371	371	416	162
R063	0.12	30-60	192	247	227	282	/	/	124
	0.18	30-60	192	247	227	282	/	/	124
	0.25	30-60	214	259	254	309	309	349	139
	0.37	30-60	214	259	254	309	309	349	139
	0.55	10-30	261	306	321	371	371	416	162
	0.75	10-30	261	306	321	371	371	416	162
	1.1	7-20	284	329	339	389	389	434	176
R080	1.5	7-20	309	354	364	414	414	459	176
	0.25	45-60	214	259	254	309	309	349	139
	0.37	45-60	214	259	254	309	309	349	139
	0.55	10-60	261	306	321	371	371	416	162
	0.75	10-60	261	306	321	371	371	416	162
	1.1	10-45	284	329	339	389	389	434	176
	1.5	10-45	309	354	364	414	414	459	176
	2.2	7-30	349	389	424	464	464	519	202
	3	7-30	349	389	424	464	464	519	202
R100	4	7-30	412	462	487	519	519	592	220
	0.55	20-60	261	306	321	371	371	416	162
	0.75	20-60	261	306	321	371	371	416	162
	1.1	7-60	284	329	339	389	389	434	176
	1.5	7-60	309	354	364	414	414	459	176
	2.2	7-30	349	389	424	464	464	519	202
	3	7-30	349	389	424	464	464	519	202
	4	7-30	451	501	526	576	576	631	220
	5.5	7-15	459	509	539	584	584	639	259
R125	7.5	7-10	497	547	577	622	622	677	259
	1.1	45-60	284	329	339	389	389	434	176
	1.5	45-60	309	354	364	414	414	459	176
	2.2	7-60	349	389	424	464	464	519	202
	3	7-60	349	389	424	464	464	519	202
	4	7-60	412	462	487	519	519	592	220
	5.5	7-45	423	473	503	548	548	603	259
	7.5	7-45	497	547	577	622	622	677	259
	11	7-10	551	586	646	676	676	726	314
R160	2.2	30-60	349	389	424	464	464	519	202
	3	30-60	349	389	424	464	464	519	202
	4	30-60	412	462	487	519	519	592	220
	5.5	15-60	423	473	503	548	548	603	259
	7.5	15-60	461	511	541	586	586	641	259
	11	15-30	530	570	625	660	660	710	314
R200	15	15-30	565	600	660	690	690	740	314
	5.5	30-45	423	473	503	548	548	603	259
	7.5	30-45	461	511	541	586	586	641	259
	11	15-45	530	570	625	660	660	710	314
	15	15-45	565	600	660	690	690	740	314
	18.5	15	596	626	706	731	731	776	359
R250	22	15	644	674	754	779	789	824	359
	11	30-45	530	570	625	660	660	710	314
	15	30-45	565	600	660	690	690	740	314
	18.5	15-45	596	626	706	731	731	776	359
	22	15-45	644	674	754	779	789	824	359
	30	15	687	692	802	807	807	852	398

7.2 直连MU电机尺寸图

7.2 Dimensions for Directly-connected Motor MU

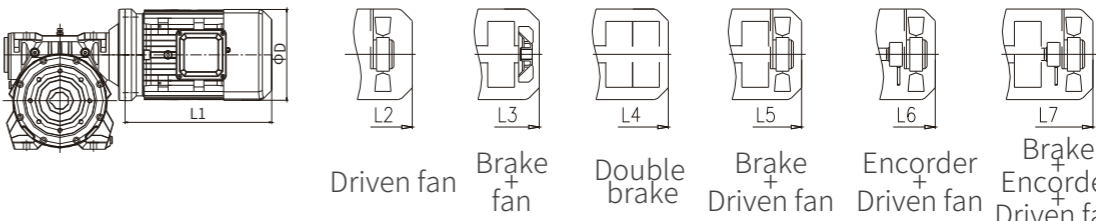

Size	P1/KW	iN	L1	L2	L3	L5	L6	L7	D
R050	0.12	7-60	192	247	227	282	/	/	124
	0.18	7-60	221	271	261	316	/	/	139
	0.25	7-60	214	264	254	309	309	349	139
	0.37	7-60	271	316	331	376	376	421	159
	0.55	7-20	261	306	321	366	366	411	159
	0.75	7-20	323	368	378	428	428	478	176
R063	0.12	30-60	192	247	227	282	/	/	124
	0.18	30-60	221	271	261	316	/	/	139
	0.25	30-60	214	264	254	309	309	349	139
	0.37	30-60	271	316	331	376	376	421	159
	0.55	10-30	261	306	321	366	366	411	159
	0.75	10-30	294	339	349	399	399	444	176
	1.1	7-20	309	354	364	414	414	459	176
	1.5	7-20	394	434	469	509	509	639	199
	0.25	45-60	214	264	254	309	309	349	139
R080	0.37	45-60	271	316	331	376	376	421	159
	0.55	10-60	261	306	321	366	366	411	159
	0.75	10-60	294	339	349	399	399	444	176
	1.1	10-45	309	354	364	414	414	459	176
	1.5	10-45	359	414	434	494	494	539	199
	2.2	7-30	349	404	424	484	484	529	199
	3	7-30	412	472	487	552	552	592	220
	4	7-30	443	508	523	593	593	623	220
	0.55	20-60	261	306	321	366	366	411	159
R100	0.75	20-60	294	339	349	399	399	444	176
	1.1	7-60	309	354	364	414	414	459	176
	1.5	7-60	359	414	434	494	494	539	199
	2.2	7-30	349	404	424	484	484	529	199
	3	7-30	412	472	487	552	552	592	220
	4	7-30	459	509	539	584	584	639	259
	5.5	7-15	497	547	577	622	622	677	259
	7.5	7-10	551	586	646	681	681	736	314
	1.1	45-60	309	354	364	414	414	459	176
R125	1.5	45-60	359	414	434	494	494	539	199
	2.2	7-60	349	404	424	484	484	529	199
	3	7-60	412	472	487	552	552	592	220
	4	7-60	443	508	523	593	593	623	259
	5.5	7-45	461	526	541	611	611	641	259
	7.5	7-45	551	586	646	681	681	736	314
	11	7-10	581	616	676	711	711	766	314
	2.2	30-60	349	404	424	484	484	529	199
	3	30-60	412	472	487	552	552	592	220
R160	4	30-60	443	508	523	593	593	623	259
	5.5	15-60	461	526	541	611	611	641	259
	7.5	15-60	565	615	660	715	715	750	314
	11	15-30	565	615	660	715	715	750	314
	15	15-30	596	641	706	751	751	791	356
	5.5	30-45	461	526	541	611	611	641	259
	7.5	30-45	565	615	660	715	715	750	314
	11	15-45	565	615	660	715	715	750	314
	15	15-45	596	641	706	751	751	791	356
R200	18.5	15	644	689	754	799	799	839	356
	22	15	705	710	820	825	825	880	398
	11	30-45	530	570	625	660	660	710	314
	15	30-45	565	600	660	690	690	740	356
	18.5	15-45	596	626	706	731	731	776	356
	22	15-45	644	674	754	779	789	824	398

8 轴输入及同向输出轴尺寸 8 Shaft input and homodromous shaft dimension

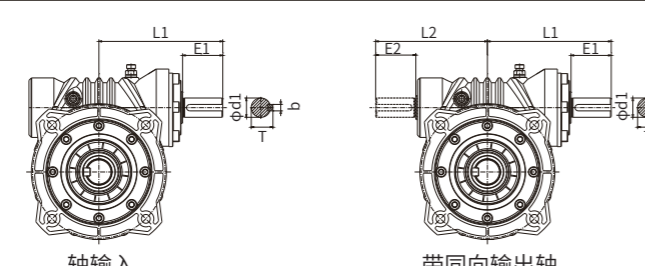

	R050	R063	R080	R100	R125	R160	R200	R250
L1	102	128	154	183	225	280	358	427
L2	92	115	139	183	225	280	358	427
E1	30	40	50	60	60	80	110	120
E2	30	40	50	60	60	80	110	120
d1	14k6	19k6	24k6	28k6	28k6	38k6	48k6	60m6
T	16	21.5	27	32	31	41	51.5	54
b	5	6	8	8	8	10	14	18

9 输入法兰与轴孔尺寸

9 Dimensions of Input Flange and Shaft Bore

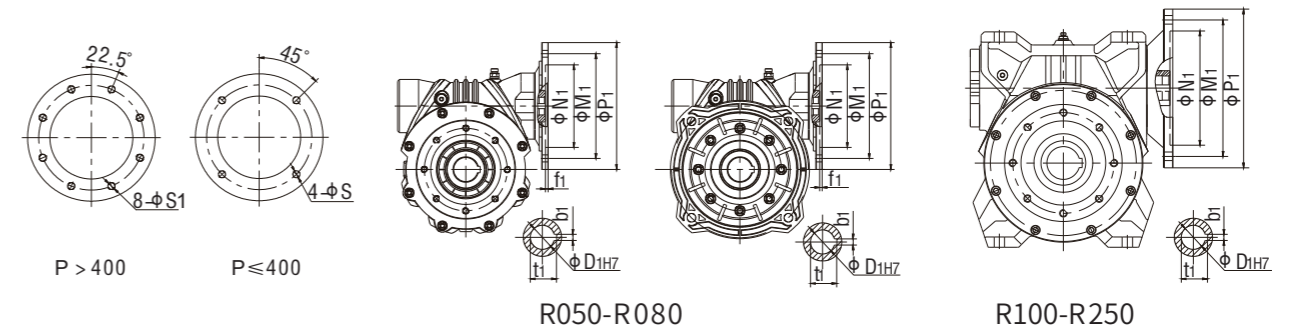

Size	D1 蜗杆标准孔径 D1 Standard bore diameter of D1 worm rod								法兰尺寸 Flange dimensions							
	IN								b1	t1	N1	M1	P1	S1	f1	代号
	7	10	15	20	30	45	60									
R050	19	19	19	19	/	/	/	6	21.8	130	165	200	Φ11	4	AF80	
	14	14	14	14	14	14	14	5	16.8	110	130	160	Φ9	4	AF71	
	11	11	11	11	11	11	11	4	12.8	95	115	140	Φ9	3	AF63	
R063	24	24	24	24	/	/	/	8	27.3	130	165	200	Φ11	5	AF90	
	/	19	19	19	19	/	/	6	21.8						AF80	
	/	/	/	/	14	14	14	5	16.8						110	130
R080	/	/	/	/	11	11	11	4	12.8	95	115	140	Φ9	3	AF63	
	28	28	28	28	28	/	/	8	31.3	180	215	250	Φ13.5	4.5	AF100	
	/	24	24	24	24	24	/	8	27.3	130	165	200	Φ11	5	AF90	
	/	19	19	19	19	19	19	6	21.8						AF80	
R100	/	/	/	/	/	14	14	5	16.8	110	130	160	Φ9	4	AF71	
	28	28	28	28	28	/	/	8	31.3	180	215	250	Φ13.5	4.5	AF100	
	24	24	24	24	24	24	24	8	27.3	130	165	200	Φ11	5	AF90	
/	/	/	19	19	19	19	6	21.8	AF80							
R125	38	38	38	38	38	38	/	10	41.3	230	265	300	Φ13.5	4.5	AF132	
	28	28	28	28	28	28	28	8	31.3	180	215	250	Φ13.5	4.5	AF100	
	/	/	/	/	/	24	24	8	27.3	130	165	200	Φ9	4	AF90	
R160	/	/	42	/	42	/	/	12	45.3	250	300	350	M16	5	AF160	
	/	/	38	/	38	38	38	10	41.3	230	265	300	M12	4.5	AF132	
	/	/	/	/	28	28	28	8	31.3	180	215	250	Φ13.5	4.5	AF100	
R200	/	/	48	/	/	/	/	14	51.8	250	300	350	M16	5.5	AF180	
	/	/	42	/	42	42	/	12	45.3						AF160	
	/	/	/	/	38	38	/	10	41.3						230	265
R250	/	/	55	/	/	/	/	16	59.3	300	350	400	M16	5.5	AF200	
	/	/	48	/	48	48	/	14	51.8	250	300	350	M16	5.5	AF180	
	/	/	/	/	42	42	/	12	45.3	180	215	250	Φ13.5	4.5	AF160	

10 组合型

10.1 R../C..组合型

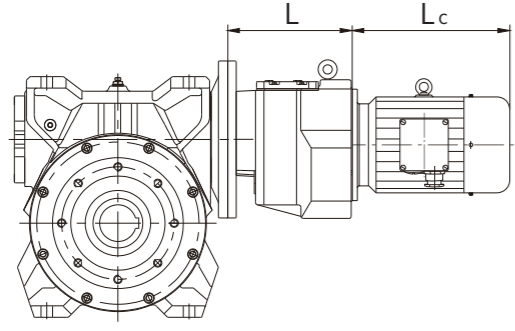
	型号 type	L
	R125/C304	182
	R160/C306	213
	R200/C307	226
	R250/C308	281

10.2 组合型尺寸及布置形式

10 Combined type

10.1 R../C..Combined type

10.2 Dimensions and arrangement of Combined -type

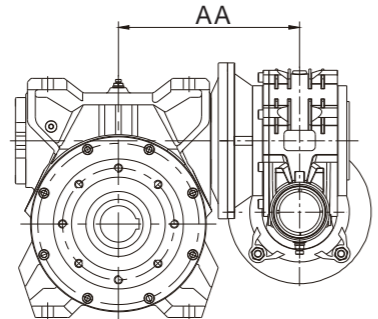
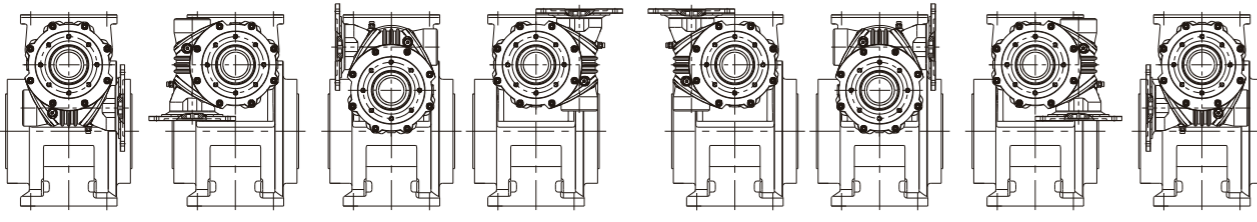
								
	R050/R050	R063/R050	R080/R050	R100/R050	R125/R063	R160/R080	R200/R100	R250/R125
AA	148	155	180	200	245	310	360	460
组合布置形式代号				Combine-type Designs				
								
<p>ZR01 ZR02 ZR03 ZR04 ZR05 ZR06 ZR07 ZR08</p>								

11 润滑油

11 Lubrication oil

单位: L Unit:(L)

规格 size 安装 mounting 方位 position	R050	R063	R080	R100	R125	R160	R200	R250
D1	0.25	0.5	0.75	1	8	15	30	55
D2/D4	0.3	0.5	0.75	1	10	20	35	60
D5/D6	0.25	0.5	0.75	1	3.5	6	10	17.5
D3	0.25	0.5	0.75	1	6	10	20	35

△ 注:产品使用环境温度-20℃~+40℃时,
1.R050~R080系列推荐采用000#极压锂基润滑脂。
2.R100~R250推荐采用蜗轮蜗杆润滑油,粘度牌号:ISOVG680。
(1)当使用环境温度低于-10℃时必须使用合成油;
(2)为确保产品的使用寿命,推荐使用合成油;
(3)使用环境温度超出上述范围时, 请向BONENG咨询。

△ Note: when ambient temperature is-20℃-40℃.
1.R050-R080Series are recommended to apply 000# pole pressure lithium lubrication grease when delivered,the code is UV00;
2.R100-R250 are recommended to apply worm rod lubrication, oil viscosity brand number:ISO VG680.
(1) When ambient temperature is lower than -10℃,synthetic oil should be used;
(2) To ensure lifespan of the product,we recommend synthetic oil;
(3) When ambient temperature exceeds the above range,

随着技术迭代进步,博能产品样本将会同步更新,请见谅。
Along with the technology advancedet.,the product of the manual of Boneng will be changed,please forgive.

控制层 CONTROL

驱动层 DRIVE

马达层 MOTOR

齿轮层 GEAR



X3010 PLC
EtherCAT&Modbus
24VDC



X3050 运动控制器
Motion Controller
EtherCAT&Modbus
24VDC

C/F/K/S-M
* . . . D
马达分布式
变频驱动器
Integrated
Gearmotor
Drive

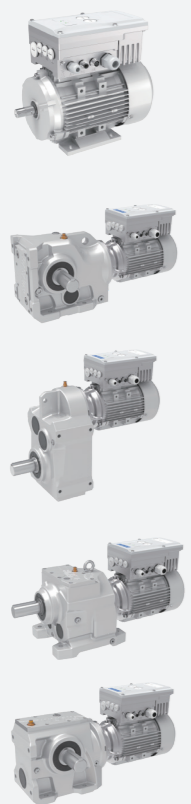

EtherCAT&
Modbus
380~480VAC
0.25~3kW
i=4~355

AM 变频驱动器
Variable Frequency Drive



Modbus
380~480VAC
0.75~5.5kW

A1 变频驱动器
Variable Frequency Drive



Modbus/CANopen
/PROFINET
380~480VAC
0.75~250kW

C/F/K/S/R
齿轮马达
Gearmotor



380~480VAC
0.09~200kW
i=1.25~500

MP/MU/MA
三相交流异步马达
Asynchronous Motor



380~480VAC
0.09~90kW
960/1450r/min
1160/1750r/min

HB/BE/HK
齿轮箱
Gearbox



4.2~15775kW
i=5.6~450

P/PK
行星齿轮箱
Planetary
Gearbox



0.4~14000kW
i=25~4000

PW
卷扬齿轮箱
Planetary
Winch
Gearbox

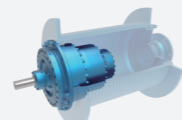

1~1810kW
i=13~940

PS
回转齿轮箱
Planetary
Slewing
Gearbox



1~1626kW
i=14~947

J/JB
升降机
Jack



0.35~22.63kW
i=5~34

T
转向箱
Spiral Bevel
Gearbox

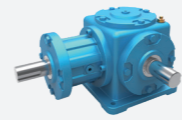

0.08~303kW
i=1:1~3:1

MX&AX
伺服马达&伺
服驱动器
Permanent
Magnet
Servo Motor
& Servo Drive



EtherCAT/
PROFINET
380~480VAC
0.28~14kW
1500/2000r/min
3000/4500r/min

C/F/K/S-MX
&AX齿轮伺
服马达&伺
服驱动器
Servo
Gearmotor
& Servo Drive

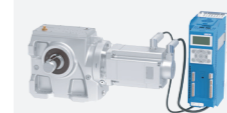
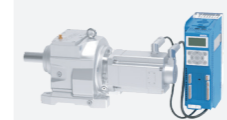
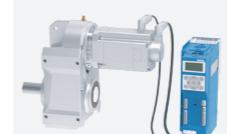
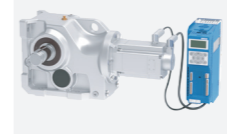

EtherCAT/
PROFINET
380~480VAC
0.28~14kW
i=1.25~315

PX-MX&AX
行星伺服马达
&伺服驱动器
Planetary
Precision Gear
Servo Motor
& Servo Drive

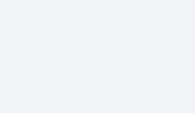
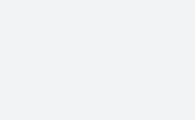

EtherCAT/
PROFINET
380~480VAC
0.38~14kW
i=3~100

PN-MN&AN
行星伺服马达
&伺服驱动器
Planetary
Precision Gear
Servo Motor
& Servo Drive

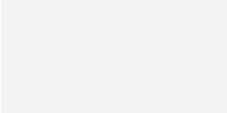

EtherCAT
PROFINET
380~480VAC
0.28~5.03kW
i=3~100

ME&AN
永磁同步伺服马
达&伺服驱动器
Permanent
Magnet
Servo Motor
& Servo Drive



EtherCAT/
PROFINET
200~240VAC
0.1kW~1.2kW

博能传动(沈阳)有限公司	BONENG TRANSMISSION(SHENYANG)CO.,LTD.
辽宁省沈阳市沈北新区 太平洋工业城A区A73-6号 电话: 024-31271571	No. A73-6, Area A, Pacific Industrial City, Shenbei New District, Shenyang, Liaoning Province, China TEL: 024-31271571
博能传动(天津)有限公司	BONENG TRANSMISSION(TIANJIN)CO.,LTD.
天津市北辰区双海道6号 宏鹏工业园7号车间 电话: 022-26929556	7th Workshop, Hongpeng Industrial Park, No. 6 Shuanghai Road, Beichen District, Tianjin City,China TEL: 022-26929556
博能传动(潍坊)有限公司	BONENG TRANSMISSION(WEIFANG)CO.,LTD.
山东省潍坊市安丘市经济开发区 汶水路与昆仑大街交叉口往北 100米路东1号车间 电话: 0536-2141166	1st Workshop, Economic Development Zone, Anqiu, Weifang City, Shandong Province, China TEL: 0536-2141166
博能传动(开封)有限公司	BONENG TRANSMISSION(KAIFENG)CO.,LTD.
河南省开封市宋城路四大街11号 海神机械院内五号厂房 电话: 0371-23335238	5th Workshop, Haishen Machinery, No.11, Fourth Street, Songcheng Road,New District, Kaifeng City, Henan Province, China TEL: 0371-23335238
博能传动(长沙)有限公司	BONENG TRANSMISSION(CHANGSHA)CO.,LTD.
湖南省长沙市望城经济开发区 普瑞大道1288号 电话: 0731-88386958	No. 1288 Puri Avenue, Wangcheng Economic Development Zone, Changsha City, Hunan Province, China TEL: 0731-88386958
博能传动设备(成都)有限公司	BONENG TRANSMISSION EQUIPMENT(CHENGDU) CO., LTD.
四川省成都市金牛区金牛坝路9号5栋 向荣中心A座7楼-703 电话: 028-87741100	703, 7th Floor, Block A, Xiangrong Center, Building 5, No. 9 Jinniuba Road, Jinniu District, Chengdu City, Sichuan Province, China TEL: 028-87741100
博能传动(肇庆)有限公司	BONENG TRANSMISSION(ZHAOQING)CO.,LTD.
广东省肇庆市鼎湖区肇庆新区 科创大道7号平谦国际现代产业园 一期A12北厂房 电话: 0757-86719757	No. 7 Science and Technology Innovation Avenue, Zhaoqing New Area, Dinghu District, Zhaoqing City, Guangdong Province, China TEL: 0757-86719757
博能传动(苏州)有限公司	BONENG TRANSMISSION(SUZHOU)CO.,LTD.
江苏省苏州市相城区如元路100号 电话: 0512-66189662	No. 100, Ruyuan Road, Xiangcheng District, Suzhou, Jiangsu Province, China TEL: 0512-66189662

博能传动(美国)有限公司	BONENG TRANSMISSION(USA)LLC.
1250 E 222nd Euclid, OH 44117, United Staes TEL: 1-216-618-0138 TEL: 1-216-618-0496 TEL: 1-216-618-3099	1250 E 222nd Euclid, OH 44117, United Staes TEL: 1-216-618-0138 TEL: 1-216-618-0496 TEL: 1-216-618-3099
博能传动(印度)有限公司	BONENG TRANSMISSION(INDIA)PVT.LTD
Plot No. E-10/3, MIDC sinnar (Malegaon) Industrial Area, Nashik, 422123, Maharashtra, India. TEL:+91-11- 4507 6293 (DELHI) TEL:+91-22-2781 3385 (MUMBAI)	Plot No. E-10/3, MIDC sinnar (Malegaon) Industrial Area, Nashik, 422123, Maharashtra, India. TEL:+91-11- 4507 6293 (DELHI) TEL:+91-22-2781 3385 (MUMBAI)