

S 斜齿-蜗轮  
齿轮马达

S Helical-Worm  
Gearmotor

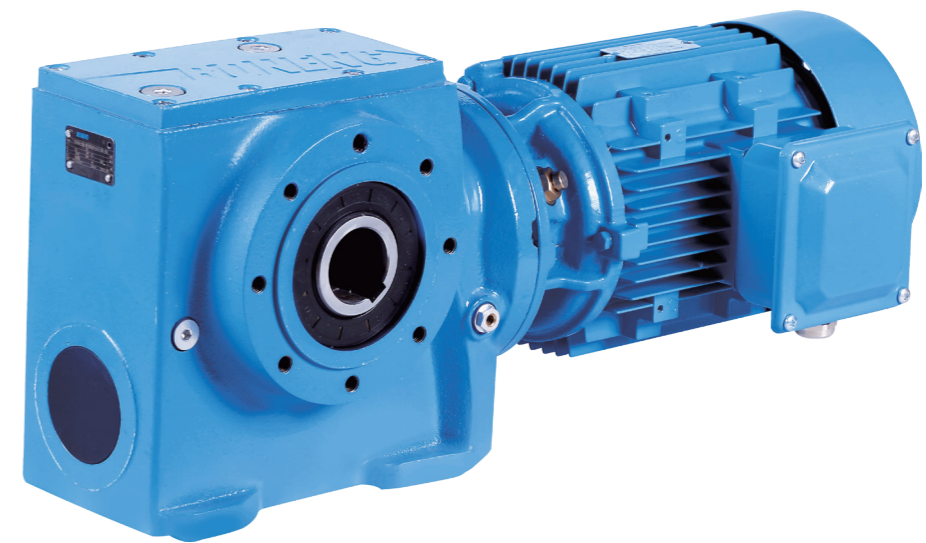

S斜齿-蜗轮  
齿轮马达

S Helical-Worm  
Gearmotor

Modified date 04/2026  
Selection Sample C05.0027



Boneng Transmission

enhances reliable, accurate, efficient and intelligent operation in the industry

控制器/驱动器/马达/  
齿轮马达/齿轮箱

Controller/ Drive/ Motor/  
Gearmotor/ Gearbox

## S斜齿-蜗轮齿轮马达

- ◆ 灵活多变的模块化理念设计的低齿隙齿轮马达。
- ◆ 拟生态外观设计，为您的品牌形象添彩。
- ◆ 更大的速比覆盖范围，满足更小和更大速比传动要求，应用场合更加广泛。
- ◆ 有限元优化铸造箱体，提高30%的运行稳定性，有效降低整机噪音。
- ◆ 大模数齿轮设计和增强型轴承配置保证产品更高的可靠性和更长的使用寿命。
- ◆ 高达94%的模块化设计，便于当地组装生产，更加快捷的生产和物流周期。
- ◆ 更高的功率密度可为您节省设备安装空间，整体结构更加紧密。
- ◆ 高可靠性和长设计寿命可有效降低您的使用成本及维护成本。
- ◆ 多种输出及布置形式可满足400多种安装使用方式。

## S Helical-Worm Gearmotor

- ◆ Low backlash gearmotor designed with flexible and modular concept.
- ◆ Excellent ecological design adds luster to your brand image.
- ◆ Larger speed ratio coverage, meeting smaller and larger speed ratio transmission requirements, and wider application scenarios.
- ◆ The FEA design of the casting housing, which improves the running stability by 30% and effectively reduces the noise of the whole machine.
- ◆ The large-modulus gear design and enhanced bearing arrangement ensure higher reliability and longer service life.
- ◆ Up to 94% modular design, international production, faster production and logistics cycles.
- ◆ Higher power density can save you mounting space and the overall structure is more compact.
- ◆ High reliability and long design life can effectively reduce your use and maintenance costs.
- ◆ A variety of output and assemblies can meet more than 400 mounting cases.



产品广泛应用于物流、环保、橡胶、包装、造纸、纺织 等各个领域。

博能传动公司总部和各大区域的技术专家以及各区域办事处的应用工程师、售后服务技师竭诚为您提供全面的技术咨询和完美的服务。

Products are widely used in Logistics, Environmental protection, Rubber, Packaging, Paper, Textile and other fields.

Boneng Transmission company headquarters and major regional technical experts and regional offices of the application engineers, after-sales service technicians dedicated to provide you with comprehensive technical advice and perfect service.

# 目录

# Contents

## 注意事项:

- ◆ 样本中的结构示意图、外形图及其他附图只属范例，无严格比例要求。（未注尺寸单位均为mm）。
- ◆ 所注重量仅为平均值，并不具有约束力。

## ⚠️ 必须严格遵守以下各项:

- ◆ 为防止意外事故发生，所有旋转部件均按照使用者所在国家和地区的安全规范由购置方加罩保护。
- ◆ 试车之前必须认真阅读使用说明书。
- ◆ 齿轮马达在供货时已处于准运行状态，运行前需加注润滑油。
- ◆ 本样本中注油量只作为参考值，实际注油量应以油镜上的标记为准。
- ◆ 润滑油粘度应按齿轮马达使用工况及使用环境温度选取。
- ◆ 推荐采用知名品牌的润滑油。

## Note:

- ◆ The structure scheme, appearance diagram and other attached diagrams in sample are examples, there is no strict proportion requirement. (The unmarked dimension units are mm).
- ◆ The marked weight is average value, it has no constraint force.

## ⚠️ You must conform to the following instructions:

- ◆ To prevent accidents, all the rotation parts are added with protective covers according to the safety regulations of the nation and region.
- ◆ Before debugging, you should carefully read instruction book.
- ◆ Gearbox is on running-permission status when delivered, you should add lubrication oil before putting it into running.
- ◆ The marked oil quantity in sample is only reference value, actual oil filling quantity should be the same with the mark on oil immersion lens.
- ◆ Lubrication oil viscosity should be selected according to working situation and application environment temperature of gearmotor.
- ◆ You can only apply lubrication oil of internationally famous brand.

01. 型号表示方法 .....	01
02. 选型及举例 .....	05
03. 传动能力表 .....	09
04. 允许的径向力 .....	13
05. 外形尺寸图表 .....	15
06. 输入法兰和输入轴 .....	41
07. 外形尺寸图（附表） ..	48
08. 马达防雨罩尺寸 .....	49
09. 被驱动轴推荐尺寸 .....	49
10. 轴端中心孔 .....	51
11. 平键与键槽的尺寸 .....	52
12. 逆止器与齿轮马达输出 旋向对照表 .....	53
13. 润滑油 .....	54
14. 重量表 .....	55

01. Type Designation .....	03
02. Type Selection and Example .....	07
03. Transmission Capacity .....	09
04. Permissible Radial Force .....	13
05. Dimensions .....	15
06. Input Flange and Input shaft .....	41
07. Dimensions(Supplement) ..	48
08. Motor Rainproof Cover Dimensions .....	49
09. Recommended Dimensions for Driven Equipment Shaft ..	49
10. Shaft End Centre Hole .....	51
11. Dimension of Parallel Key and Keyway .....	52
12. Comparison table of backstop and motor output rotation direction .....	53
13. Oil .....	54
14. Weight .....	55

### 1 型号表示方法



### 公称减速比代号

D1/D2/D3/D4/D5/D6

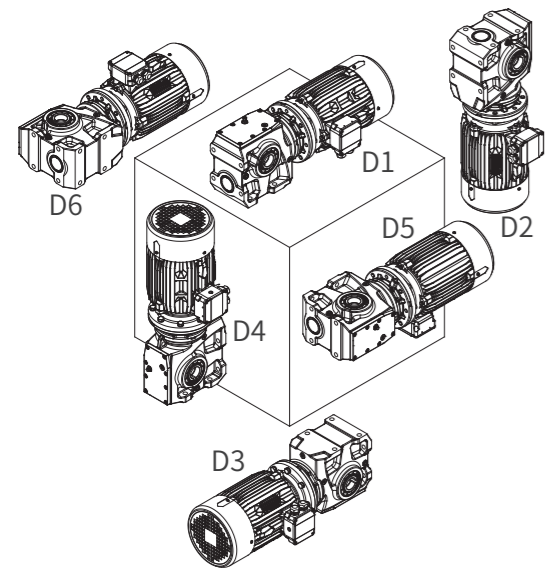

### 可选附件和指定配置

0=无可选

### 润滑油代号

0=不加润滑油 (不加油出厂时, 请选此项)  
 4=矿物润滑油VG680 (环境温度为-20°C~+40°C, 需加油出厂时, 请选此项)

- ◆配IEC马达输入法兰的齿轮箱型号示例:S208HA-C32-D100-AP112
- ◆配NEMA马达输入法兰的齿轮箱型号示例:S208HA-C32-D100-AN145
- ◆配输入轴的齿轮箱型号示例:S208HA-C32-D100-AE3

MP132M4B55AC 3 - A 0 N 0 0 - 0 1 1

- 进线孔位置 1/2/3/4
- 接线盒位置 1/2/3/4
- 安装方位0
- 防护等级 0=标准配置
- 热保护和加热保护 0=无绕组保护 1=热敏电阻 2=热敏开关 3=温度传感器PT100 4=加热带 5=热敏电阻和加热带 6=热敏开关和加热带 7=温度传感器PT100和加热带
- 制动器和逆止器 (旋向关系见: “可选附件和指定配置”)
- 编码器 0=无编码器 3=经济型HTL编码器 (1024P) 4=高性能TTL编码器 (1024P) 1=高性能HTL编码器 (1024P) 2=标配编码器附件
- 冷却方式 A=自扇冷却 F=强冷风机 (配编码器必选; 其他不建议选) N=自然冷却 (双制动马达专用)

### 马达接线盒和进线孔位置(视角:马达尾部)

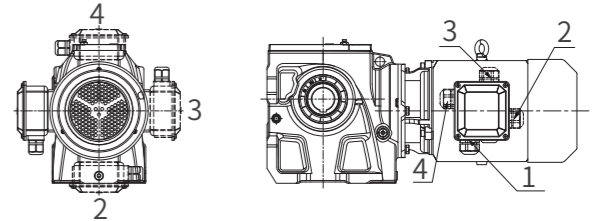

整机标配颜色 (RAL5015)  
 1=带防雨罩 J=带金属接头 K=带金属接头和防雨罩  
 4=IP65/金属接头 (制动器和风机防护IP55) 5=IP65/金属接头和带防雨罩 (制动器和风机防护IP55)

N=无制动器 A=220-240VAC制动器 D=220-240VAC制动器带手柄 B=380-415VAC制动器 E=380-415VAC制动器带手柄 S=380-415VAC双制动器带手柄 R=220-240VAC双制动器带手柄 P=逆止器(顺时针, 机座100~280) Q=逆止器(逆时针, 机座100~280)	N=无制动器 B=380-415VAC制动器 E=380-415VAC制动器带手柄 S=380-415VAC双制动器带手柄 P=逆止器(顺时针, 机座100~280) Q=逆止器(逆时针, 机座100~280)	N=无制动器 A=220-240VAC制动器 D=220-240VAC制动器带手柄 P=逆止器(顺时针, 机座100~280) Q=逆止器(逆时针, 机座100~280)
--	--	---

频率/电压 1=50Hz 220V△/380VY 2=50Hz 230V△/400VY 7=60Hz 440VY 8=60Hz 460VY A=50Hz 240V△/415VY C=60Hz 480VY E=60Hz 220V△/380VY	频率/电压 3=50Hz 380V△/660VY 4=50Hz 400V△/690VY 5=60Hz 440V△ 6=60Hz 460V△ B=50Hz 415V△ D=60Hz 480V△ F=60Hz 380V△	频率/电压 G=60Hz 230VY 8=60Hz 460VY J=60Hz 575VY	频率/电压 H=60Hz 230V△ 6=60Hz 460V△ K=60Hz 575V△
---	---	---	---

### 三相交流异步马达4极规格

功率 (kW)	MP=IE3 MU=IE4	功率 (kW)	MP=IE3 MU=IE4	功率 (kW)	MA=MG1	功率 (kW)	MA=MG1
0.12	MP063M4A12AL MU063M4A12AL	4	MP112L4B40AC MU132S4B40AC	0.12	MA063M4A12AL	4	MA112L4B40AC
0.18	MP063M4A18AL MU071M4A18AL	5.5	MP132M4B55AC MU132M4B55AC	0.18	MA063M4A18AL	5.5	MA132L4B55AC
0.25	MP071M4A25AL MU071M4A25AL	7.5	MP132L4B75AC MU160M4B75AC	0.25	MA071M4A25AL	7.5	MA132L4B75AC
0.37	MP071M4A37AL MU080M4A37AL	11	MP160M4C11AC MU160L4C11AC	0.37	MA071M4A37AL	11	MA160M4C11AC
0.55	MP080M4A55AL MU080M4A55AL	15	MP160L4C15AC MU180M4C15AC	0.55	MA080M4A55AL	15	MA160L4C15AC
0.75	MP080M4A75AL MU090S4A75AL	18.5	MP180M4C18AC MU180L4C18AC	0.75	MA080M4A75AL	18.5	MA180M4C18AC
1.1	MP090S4B11AL MU090L4B11AL	22	MP180L4C22AC MU200L4C22AC	1.1	MA090M4B11AL	22	MA180L4C22AC
1.5	MP090M4B15AL MU100L4B15AL	30	MP200M4C30AC MU225S4C30AC	1.5	MA090M4B15AL	30	MA200M4C30AC
2.2	MP100M4B22AL MU100L4B22AL	37	MP225M4C37AC MU225M4C37AC	2.2	MA100M4B22AL	37	MA225M4C37AC
3	MP100M4B30AL MU112M4B30AC	45	MP225M4C45AC MU250M4C45AC	3	MA100M4B30AL	45	MA225M4C45AC
/	/	55	MP250M4C55AC MU280S4C55AC	/	/	55	MA250M4C55AC
/	/	75	MP280S4C75AC MU280M4C75AC	/	/	75	MA280S4C75AC
/	/	90	MP280M4C90AC MU280M4C90AC	/	/	90	MA280M4C90AC

### 1 Type Designation

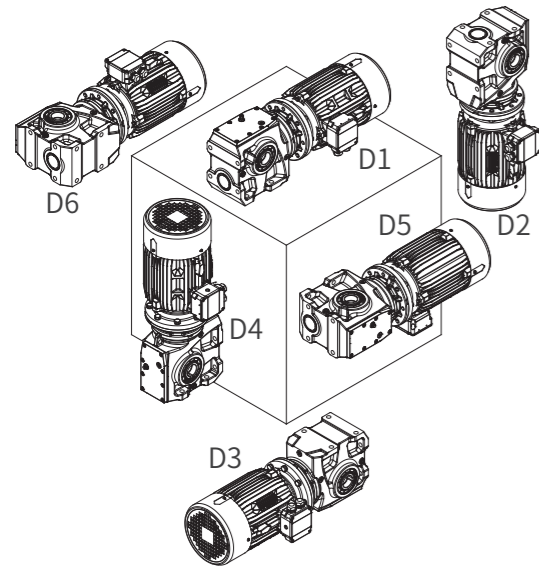
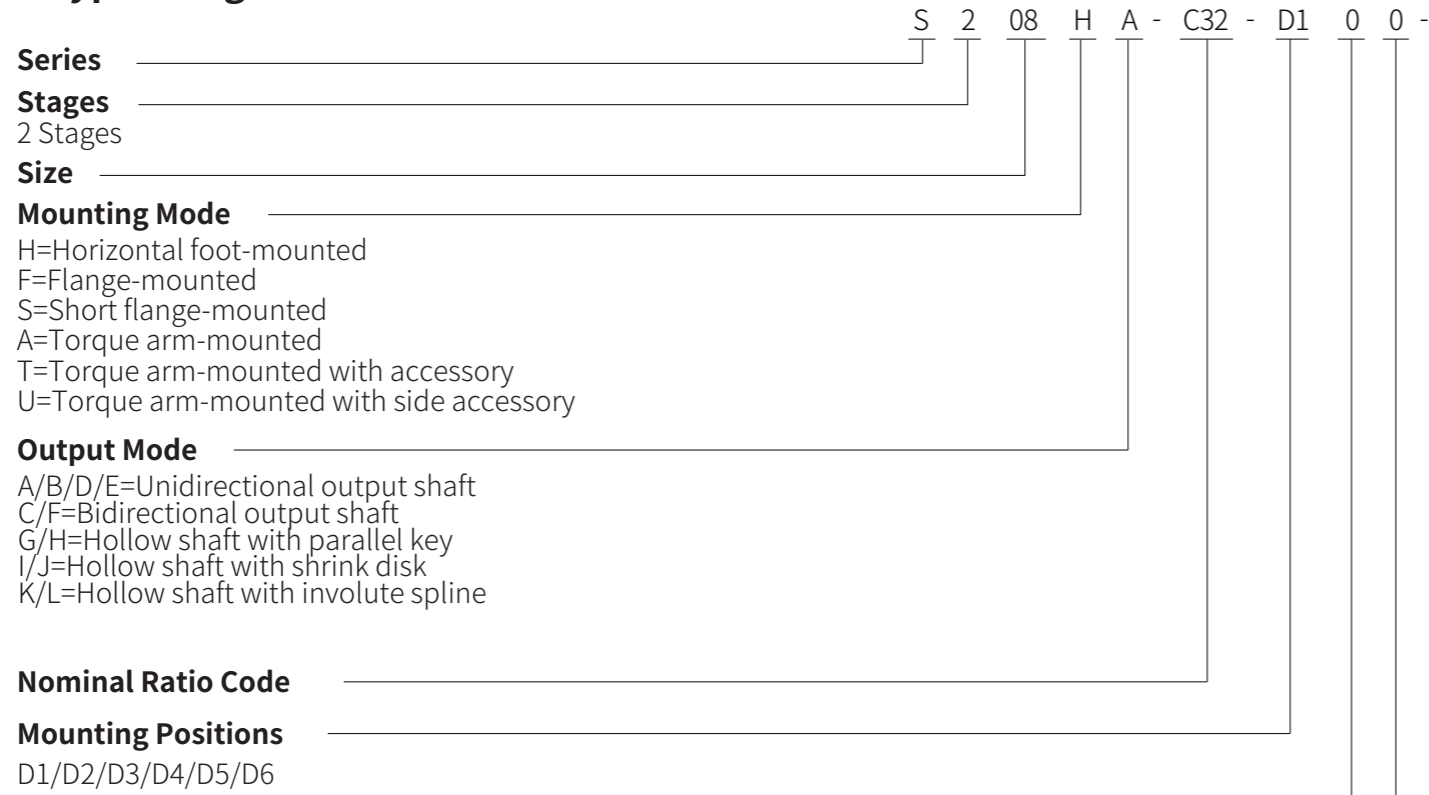

#### Accessories and Specific Configuration

0=None

#### Oil Code

0=Without oil filling(Please select this option when you do not need lubricating oil);  
 4=With mineral oil VG680(Please select this option when the ambient temperature is -20°C~+40°C,and you need lubricating oil);

- ◆Example of gearbox with input flange for IEC motor connection:S208HA-C32-D100-AP112
- ◆Example of gearbox with input flange for NEMA motor connection:S208HA-C32-D100-AN145
- ◆Example of gearbox with input shaft:S208HA-C32-D100-AE3

MP132M4B55AC 3 - A 0 N 0 0 - 0 1 1

#### Cable Entry Position

1/2/3/4

#### Terminal Box Position

1/2/3/4

#### Motor Mounting Position 0

#### Motor protection

0=Standard configuration  
 1=With rain cover  
 J=With metal joint

#### Thermal Protection and Heating Protection

0=Without thermal protection  
 1=Thermistor  
 2=Thermal switch  
 3=PT100 temperature sensor  
 4=Heating belt  
 5=Thermistor and heating belt and heating protection  
 6=Thermal switch and heating belt  
 7=PT100 temperature sensor and heating belt

#### Brakes and Backstop (Relationship of rotational direction can be checked in "Accessories & Specific Configuration".)

N=No brake A=220-240VAC Brake D=220-240VAC Brake with release handle B=380-415VAC Brake E=380-415VAC Brake with release handle R=220-240VAC Double brake with release handle S=380-415VAC Double brake with release handle P=Backstop (CW, for size: 100~280) Q=Backstop (CCW, for size: 100~280)	N=No brake A=220-240VAC Brake D=220-240VAC Brake with release handle B=380-415VAC Brake E=380-415VAC Brake with release handle S=380-415VAC Double brake with release handle P=Backstop (CW, for size: 100~280) Q=Backstop (CCW, for size: 100~280)	N=No brake A=220-240VAC Brake D=220-240VAC Brake with release handle P=Backstop (CW, for size: 100~280) Q=Backstop (CCW, for size: 100~280)
---	--	---

#### Encoder

0=No encoder  
 1=High-performance HTL encoder(1024P)  
 2=Standard encoder accessories  
 3=Economic HTL encoder(1024P)  
 4=High-performance TTL encoder(1024P)

#### Cooling Method

A=Self-fan cooling F=Forced-fan cooling N=Natural cooling (for motor with double brake)

Frequency / Voltage 1=50Hz 220V△/380VY 2=50Hz 230V△/400VY 7=60Hz 440VY 8=60Hz 460VY A=50Hz 240V△/415VY C=60Hz 480VY E=60Hz 220V△/380VY	Frequency / Voltage 3=50Hz 380V△/660VY 4=50Hz 400V△/690VY 5=60Hz 440V△ 6=60Hz 460V△ B=50Hz 415V△ D=60Hz 480V△ F=60Hz 380V△	Frequency / Voltage G=60Hz 230VY 8=60Hz 460VY J=60Hz 575VY	Frequency / Voltage H=60Hz 230V△ 6=60Hz 460V△ K=60Hz 575V△
---	---	---	---

#### Efficiency three-phase asynchronous motor (4 pole)

Power (kW)	MP=IE3 MU=IE4	Power (kW)	MP=IE3 MU=IE4	Power (kW)	MA=MG1	Power (kW)	MA=MG1
0.12	MP063M4A12AL MU063M4A12AL	4	MP112L4B40AC MU132S4B40AC	0.12	MA063M4A12AL	4	MA112L4B40AC
0.18	MP063M4A18AL MU071M4A18AL	5.5	MP132M4B55AC MU132M4B55AC	0.18	MA063M4A18AL	5.5	MA132L4B55AC
0.25	MP071M4A25AL MU071M4A25AL	7.5	MP132L4B75AC MU160M4B75AC	0.25	MA071M4A25AL	7.5	MA132L4B75AC
0.37	MP071M4A37AL MU080M4A37AL	11	MP160M4C11AC MU160L4C11AC	0.37	MA071M4A37AL	11	MA160M4C11AC
0.55	MP080M4A55AL MU080M4A55AL	15	MP160L4C15AC MU180M4C15AC	0.55	MA080M4A55AL	15	MA160L4C15AC
0.75	MP080M4A75AL MU090S4A75AL	18.5	MP180M4C18AC MU180L4C18AC	0.75	MA080M4A75AL	18.5	MA180M4C18AC
1.1	MP090S4B11AL MU090L4B11AL	22	MP180L4C22AC MU200L4C22AC	1.1	MA090M4B11AL	22	MA180L4C22AC
1.5	MP090M4B15AL MU100L4B15AL	30	MP200M4C30AC MU225S4C30AC	1.5	MA090M4B15AL	30	MA200M4C30AC
2.2	MP100M4B22AL MU100L4B22AL	37	MP225M4C37AC MU225M4C37AC	2.2	MA100M4B22AL	37	MA225M4C37AC
3	MP100M4B30AL MU112M4B30AC	45	MP225M4C45AC MU250M4C45AC	3	MA100M4B30AL	45	MA225M4C45AC
/	/	55	MP250M4C55AC MU280S4C55AC	/	/	55	MA250M4C55AC
/	/	75	MP280S4C75AC MU280M4C75AC	/	/	75	MA280S4C75AC
/	/	90	MP280M4C90AC MU280M4C90AC	/	/	90	MA280M4C90AC

#### Motor terminal box and cable entry position (View: Motor afterbody)

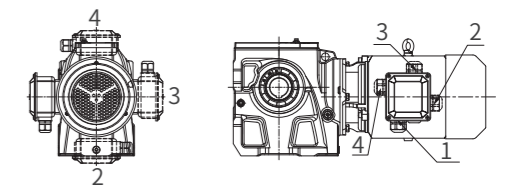

Assembly colour of gearmotor (RAL5015)

K=With metal joint and rain cover  
 4=IP65/with metal joint (brake and forced-fan IP55)  
 5=IP65/with metal joint and rain cover

## 2 选型及举例

序号	说明	代号	参数计算							
			负荷性质	每天使用时间 (小时)						
1	被驱动设备系数	f <sub>1</sub>	≤2	2~10	10~24					
			均匀负载	1.00(1.00)	1.00(1.25)	1.25(1.50)				
			一般冲击	1.00(1.25)	1.25(1.50)	1.50(1.75)				
			强烈冲击	1.25(1.50)	1.50(1.75)	1.75(2.00)				
			注: 当每小时起动、停止次数≥10次, 请使用括号内数值; 当每天使用时间≤10小时, 设备连续运转时需f <sub>1</sub> ≥1.25。							
2	环境温度系数	f <sub>t</sub>	环境温度							
			20	25	30	35	40	45	50	
			均匀负载	1.00	1.00	1.00	1.03	1.06	1.12	1.20
			一般冲击	1.00	1.01	1.02	1.06	1.12	1.16	1.30
			强烈冲击	1.00	1.02	1.04	1.10	1.17	1.20	1.40
3	输入转速	n <sub>1</sub>	≤1800r/min更高转速请咨询							
4	确定减速比	i	i=n <sub>1</sub> /n <sub>2</sub>							
5	传动效率	η	i=7.1-16	i=18-50	i=56-112	i=125-500	S/C组合			
			η	88%	77%	62%	57%	57%		
6	以被动设备所需的扭矩或功率, 确定齿轮马达的输入功率	P <sub>1</sub>	P <sub>1</sub> =T <sub>2</sub> ·n <sub>1</sub> /(9550·i·η) 或 P <sub>1</sub> =P <sub>2</sub> /η							
7	根据计算, 查传动能力表, 确定齿轮马达规格, 直联马达时需查直联马达功率表	T <sub>2N</sub> 、P <sub>1N</sub>	T <sub>2N</sub> ≥T <sub>2</sub> ·f <sub>1</sub> ·f <sub>t</sub> 或 P <sub>1N</sub> ≥P <sub>1</sub> ·f <sub>1</sub> ·f <sub>t</sub>							
8	径向力、轴向力校核	F <sub>r1</sub> /F <sub>r2</sub> F <sub>a1</sub> /F <sub>a2</sub>	查第16页, S系列F <sub>r2</sub> 表							
9	确认润滑方式		一般采用飞溅润滑							
10	确认冷却方式		一般采用自然冷却							
11	按型号表示方法确定各项		型号表示方法见第1页							
12	一般环境条件		环境温度: -20至40℃, 空旷场地通风良好, 海拔高度1000米一下, 一般工厂灰尘。							
13	特殊环境条件		高温、低温、灰尘多、化学作用(例: 酸碱等), 露天(直接日照、冰、水淋等), 请咨询。							

n<sub>2</sub>:被驱动设备所需的输出转速 P<sub>2</sub>:被驱动设备所需的输出功率 P<sub>1N</sub>:齿轮马达的额定输入功率  
T<sub>2</sub>:被驱动设备所需的输出扭矩 T<sub>2N</sub>:齿轮马达的额定输出扭矩

### 举例

#### ◆ 已知条件:

- 被驱动设备负荷性质: 一般冲击,  
工作8小时/天, 环境温度40℃, 启动频率10次/小时;
- 马达: 4极,  
转速n<sub>1</sub>=1450r/min;
- 所需功率P<sub>2</sub>=1kW,  
所需转速n<sub>2</sub>=10.4r/min;
- 安装输出形式: 法兰安装, 单向实心输出A向,  
安装方位D1, 马达接线盒2号位, 进线孔1号位。

#### ◆ 选型步骤:

- 根据负荷性质查表可得出被驱动设备系数f<sub>1</sub>=1.5;  
环境温度系数f<sub>t</sub>=1.12;
- 确定公称减速比i<sub>N</sub>:  
i=n<sub>1</sub>/n<sub>2</sub>=1450/10.4=139.4, 取公称减速比i<sub>N</sub>=140;
- 计算输入功率并确定马达功率(查表得出齿轮传动效率η=57%):  
P<sub>1</sub>≥P<sub>2</sub>/η=1/0.57=1.8kW, 取马达功率为2.2kW;  
查直联马达表, 可直联;
- 确定减速机额定功率P<sub>1N</sub>:  
P<sub>1N</sub>≥P<sub>2</sub>·f<sub>1</sub>/η=1·1.5·1.12/0.57=2.9kW;
- 根据已知条件和以上数据,  
查传动能力表可选出齿轮马达型号为:  
S208FA-D14-D100-MS100M4B22AL2-A0N00-021

## 2 Type Selection and Example

Step	Description	Symbol	Parameters Calculation and Guideline							
1	Driven Machine Factor	f <sub>1</sub>	Load Characteristic	Operating hours per day (h)						
				≤2	2~10	10~24				
			Uniform	1.00(1.00)	1.00(1.25)	1.25(1.50)				
			Moderate	1.00(1.25)	1.25(1.50)	1.50(1.75)				
			Heavy	1.25(1.50)	1.50(1.75)	1.75(2.00)				
Note: Apply values in the brackets when starts per hour are 10 times or more. If the equipment continues working and the operating time≤10h per day, then f <sub>1</sub> >1.25.										
2	Ambient temperature factor	f <sub>t</sub>	Load characteristic	Ambient temperature						
				20	25	30	35	40	45	50
			Uniform	1.00	1.00	1.00	1.03	1.06	1.12	1.20
			Moderate	1.00	1.01	1.02	1.06	1.12	1.16	1.30
			Heavy	1.00	1.02	1.04	1.10	1.17	1.20	1.40
Note: The usual working condition is: ambient temperature -10~+40°C, uniform or moderate shock, utilization ratio ≤90%, working hours/d ≤8, and input speed ≤1800rpm. If not within this range, add fans to the worm shaft end of gear units type S205 and above.										
3	Input speed	n <sub>1</sub>	≤1800r/min Consult us if higher speed required.							
4	Calculation of the ratio	i	i=n <sub>1</sub> /n <sub>2</sub>							
5	Transmission efficiency	η	i=7.1-16	i=18-50	i=56-112	i=125-500	S/C combi-type			
			η	88%	77%	62%	57%	57%		
6	Calculation of the input power of the gearmotor on basis of the torque and power required by the driven machine.	P <sub>1</sub>	P <sub>1</sub> =T <sub>2</sub> · n <sub>1</sub> / (9550 · i · η) or P <sub>1</sub> =P <sub>2</sub> / η							
7	Determination of gearmotor type referring to the table of transmission capacity after calculation, For directly-connected motor, require to refer to directly connected motor power table.	T <sub>2N</sub> 、P <sub>1N</sub>	T <sub>2N</sub> ≥ T <sub>2</sub> · f <sub>1</sub> · f <sub>t</sub> or P <sub>1N</sub> ≥ P <sub>1</sub> · f <sub>1</sub> · f <sub>t</sub>							
8	Check the radial and axial forces on the shafts	F <sub>r1</sub> /F <sub>r2</sub> F <sub>a1</sub> /F <sub>a2</sub>	See P16							
9	Determination of lubrication system	/	Generally splash lubrication							
10	Determination of cooling system	/	Generally air cooling							
11	Determination of every item included in the type designation	/	For details about type designation, see P1.							
12	Normal ambient conditions	/	Ambient temperature -10 to 40 , ample space, good ventilation, altitude not exceeding 1000m and common plant dust.							
13	Special ambient conditions	/	For higher or lower temperature, dusty sites, chemical reaction (acids, alkaline, etc) , or open field (sunlight, ice, rain, etc), please consult us!							

n<sub>2</sub>: The output speed required by the driven machine. P<sub>2</sub>: The output power required by the driven machine.  
P<sub>1N</sub>: The rated input power of gearmotor. T<sub>2</sub>: The output torque required by the driven machine.  
T<sub>2N</sub>: The rated output torque of gearmotor.

### Example

◆ Known Criteria:

1、 Load characteristics by the driven machine:

Moderate, working 8 hours/d, ambient temperature 40°C, and starting 10 times/h;

2、 Normal motor: 4-pole,

speed n<sub>1</sub>=1450r/min;

3、 The power required P<sub>2</sub>=1kW,

speed n<sub>2</sub>=10.4r/min;

4、 Mounting mode: flange-mounted, unidirectional output shaft A,

mounting position D1, motor terminal box 2, cable entry position 1.

◆ Selection steps:

1、 By referring to the table of Load Characteristic,

we get the driven machine factor f<sub>1</sub>=1.5,

the ambient temperature factor f<sub>2</sub>=1.12;

2、 Calculation of the Ratio iN:

i=n<sub>1</sub>/ n<sub>2</sub>=1450/10.4=139.4, nominal ratio iN=140;

3、 Calculation of the input power and determination of the motor power

( transmission efficiency η=57%):

P<sub>1</sub> ≥ P<sub>2</sub> / η = 1 / 0.57 = 1.8kW, so 2.2kW motor is selected.

Refer to the directly-connected motor power table, it can be directly-connected;

4、 Determination of the nominal power of the geared motor P<sub>1N</sub>:

P<sub>1N</sub> ≥ P<sub>2</sub> · f<sub>1</sub> / η = 1 × 1.5 × 1.12 / 0.57 = 2.9kW;

5、 The type selected:

S208FA-D14-D100-MS100M4B322AL2-A0N00-021

### 3 传动能力表

3.1 S系列传动能力表  
S...(iN=7.1-500)

### 3 Transmission Capacity

3.1 S Transmission capacity  
S...(iN=7.1-500)

公称输入转速	公称输出转速	公称减速比代号	公称减速比	额定输出扭矩	精确减速比	额定输入功率	额定输出扭矩	精确减速比	额定输入功率	额定输出扭矩	精确减速比	额定输入功率	额定输出扭矩	精确减速比	额定输入功率	
Nominal Input Speed	Nominal Output Speed	Nominal Ratio Code	Nominal Ratio	Rated Output Torque	Exact Ratio	Rated Input Power	Rated Output Torque	Exact Ratio	Rated Input Power	Rated Output Torque	Exact Ratio	Rated Input Power	Rated Output Torque	Exact Ratio	Rated Input Power	
$n_{1N}$ (r/min)	$n_{2N}$ (r/min)	Code	$i_N$	$T_{2N}$ (N·m)	$i_{ex}$	$P_{1N}$ (kW)	$T_{2N}$ (N·m)	$i_{ex}$	$P_{1N}$ (kW)	$T_{2N}$ (N·m)	$i_{ex}$	$P_{1N}$ (kW)	$T_{2N}$ (N·m)	$i_{ex}$	$P_{1N}$ (kW)	
1450	204	B71	7.1	55	6.81	1.39	110	7.28	2.61				330	7.03	8.1	
	181	B80	8	55	7.68	1.24	110	8.03	2.36	200	7.93	4.35	350	8.37	7.2	
	161	B90	9	55	8.75	1.08	110	9.05	2.10	200	8.90	3.88	380	9.32	7.0	
	145	C10	10	60	9.89	1.05	110	10.3	1.84	200	10.1	3.43	380	10.3	6.4	
	129	C11	11.2	60	11.2	0.92	110	11.7	1.63	220	11.2	3.40	380	11.6	5.6	
	116	C13	12.5	60	12.1	0.86	110	13.2	1.44	220	12.8	2.97	400	12.7	5.4	
	104	C14	14	65	14.1	0.79	120	14.2	1.46	220	14.1	2.70	430	14.5	5.1	
	90.6	C16	16	70	16.0	0.75	120	15.8	1.31	220	15.8	2.40	450	15.4	5.0	
	80.6	C18	18	65	17.6	0.73	120	17.4	1.36	220	18.8	2.31	450	17.9	4.95	
	72.5	C20	20	70	19.3	0.72	135	19.7	1.35	220	21.1	2.06	450	20.5	4.32	
	64.7	C22	22.4	75	21.0	0.70	150	22.4	1.32	230	23.8	1.91	450	23.3	3.80	
	58.0	C25	25	75	24.0	0.62	160	25.3	1.25	250	26.4	1.87	450	26.1	3.40	
	51.8	C28	28	80	27.1	0.58	160	28.7	1.10	250	30.3	1.63	450	29.1	3.05	
	46.0	C32	31.5	80	30.7	0.51	160	30.9	1.02	250	33.2	1.48	480	31.9	2.96	
	40.8	C36	35.5	80	33.0	0.48	160	35.3	0.89	260	37.5	1.37	480	36.3	2.61	
	36.3	C40	40	80	38.7	0.41	160	38.9	0.81	260	40.1	1.28	480	39.7	2.39	
	32.2	C45	45	85	43.8	0.38	165	43.9	0.74	260	44.5	1.15	510	45.1	2.23	
	29.0	C50	50	85	48.3	0.35	180	50.0	0.71	290	50.3	1.14	540	48.0	2.22	
	25.9	C56	56	80	55.9	0.35	155	56.5	0.67	245	55.8	1.08	480	53.8	2.19	
	23.0	C63	63	85	63.1	0.33	160	64.0	0.61	270	63.9	1.03	500	61.6	1.99	
	20.4	C71	71	85	71.9	0.29	160	68.9	0.57	300	70.3	1.05	500	70.0	1.75	
	18.1	C80	80	85	81.3	0.26	170	78.2	0.53	300	79.2	0.93	500	78.3	1.56	
	16.1	C90	90	90	92.0	0.24	170	89.1	0.47	300	87.6	0.84	520	87.2	1.46	
	14.5	D10	100	95	99.1	0.23	170	100.7	0.41	310	98.9	0.77	520	95.8	1.33	
	12.9	D11	112	90	116.0	0.19	170	114.0	0.37	300	109.8	0.67	520	117.6	1.08	
	11.6	D13	125	100	131.4	0.20	170	122.8	0.37	300	125.8	0.64	520	129.3	1.07	
	10.4	D14	140	100	144.9	0.18	170	143.7	0.32	300	138.3	0.58	520	146.8	0.94	
	9.06	D16	160	100	158.4	0.17	170	162.9	0.28	300	155.9	0.51	520	160.5	0.86	
	8.06	D18	180	100	173.2	0.15	170	179.6	0.25	300	166.6	0.48	520	182.6	0.76	
	7.25	D20	200					170	196.3	0.23	300	193.6	0.41	520	194.1	0.71
	6.47	D22	224					170	214.6	0.21	300	217.9	0.37	520	224.4	0.62
	5.80	D25	250											520	266.8	0.52
5.18	D28	280											520	283.9	0.49	
4.60	D32	315											520	320.7	0.43	
4.08	D36	355														
3.63	D40	400														
3.22	D45	450														
2.90	D50	500														

注：(1)齿轮马达的实际输出转速应是实际输入转速 $n_1$ /精确减速比 $i_{ex}$ ；  
(2)齿轮马达的实际输入转速 $n_1$ 对应的额定输入功率是：  
 $P_{1N}=T_{2N} \cdot n_1 / (9550 \cdot i_{ex})$ ，公式中额定输出扭矩 $T_{2N}$ 不变。

Note: (1) Actual output speed of the gearmotor: Actual input speed ( $n_1$ )/Exact ratio ( $i_{ex}$ );  
(2) Rated input power corresponding to actual input speed of the gearmotor:  
 $P_{1N}=T_{2N} \cdot n_1 / (9550 \cdot i_{ex})$ , the rated output torque  $T_{2N}$  in the formula remains unchanged.

额定输出扭矩	精确减速比	额定输入功率	额定输出扭矩	精确减速比	额定输入功率	额定输出扭矩	精确减速比	额定输入功率	额定输出扭矩	精确减速比	额定输入功率	额定输出扭矩	精确减速比	额定输入功率
Rated Output Torque	Exact Ratio	Rated Input Power	Rated Output Torque	Exact Ratio	Rated Input Power	Rated Output Torque	Exact Ratio	Rated Input Power	Rated Output Torque	Exact Ratio	Rated Input Power	Rated Output Torque	Exact Ratio	Rated Input Power
$T_{2N}$ (N·m)	$i_{ex}$	$P_{1N}$ (kW)	$T_{2N}$ (N·m)	$i_{ex}$	$P_{1N}$ (kW)	$T_{2N}$ (N·m)	$i_{ex}$	$P_{1N}$ (kW)	$T_{2N}$ (N·m)	$i_{ex}$	$P_{1N}$ (kW)	$T_{2N}$ (N·m)	$i_{ex}$	$P_{1N}$ (kW)
S207			S208			S209			S210			S212		
700	7.41	16.3												
750	8.44	15.3												
750	9.35	13.8	1300	9.80	22.9									
750	10.7	12.1	1300	11.1	20.1									
750	12.1	10.7	1300	12.9	17.4									
820	13.6	10.4	1300	14.1	15.9									
880	15.5	9.8	1450	15.8	15.8									
850	17.2	9.7	1380	17.4	15.7	2700	18.4	28.9	3800	17.9	41.8	7000	18.1	76
950	19.7	9.5	1550	20.1	15.2	2700	21.0	25.4	3800	19.6	38.2	7000	20.2	68
1000	22.2	8.9	1600	21.4	14.8	2700	24.3	21.9	4000	23.2	34.0	7000	23.8	58
1050	23.9	8.7	1600	24.3	13.0	2900	26.5	21.6	4100	26.0	31.1	7400	25.9	56
1050	27.2	7.6	1600	29.8	10.6	3100	29.8	20.5	4300	27.7	30.6	7700	30.2	50
1100	30.1	7.2	1600	32.6	9.7	3300	32.6	19.9	4600	31.7	28.6	8200	33.5	48.3
1100	34.5	6.3	1600	37.7	8.4	3300	37.7	17.3	4700	35.3	26.3	8600	35.5	47.8
1100	38.8	5.6	1600	40.2	7.8	3300	40.2	16.2	4700	40.0	23.2	8600	40.3	42.0
1100	43.4	5.00	1600	45.7	6.9	3300	47.1	13.8	4700	44.8	20.7	8700	45.1	38.0
1100	48.3	4.49	1700	48.9	6.8	3600	50.5	14.1	4900	51.2	18.9	9000	50.1	35.4
1000	57.6	4.25	1400	57.8	5.9	3300	54.7	14.8	4400	55.0	19.6	8000	55.4	35.4
1100	64.8	4.16	1500	65.0	5.7	3300	59.6	13.6	4700	60.2	19.1	8600	62.0	34.0
1100	70.9	3.80	1700	71.2	5.8	3300	72.9	11.1	4600	71.2	15.8	8600	73.1	28.8
1100	83.3	3.23	1800	82.3	5.4	3300	82.9	9.8	4600	79.8	14.1	8600	79.3	26.5
1100	91.9	2.93	1900	87.7	5.3	3300	88.7	9.1	4700	85.2	13.5	8500	92.6	22.5
1200	105.5	2.79	2000	102.9	4.76	3300	104.7	7.7	4900	97.4	12.3	9250	102.7	22.1
1200	118.6	2.48	2000	115.7	4.23	3600	117.8	7.5	5000	112.3	10.9	9000	108.9	20.2
1200	132.6	2.41	2000	126.9	4.20	3700	129.1	7.6	5200	128.4	10.8	9200	121.5	20.2
1300	147.6	2.35	2100	146.6	3.82	3800	149.1	6.8	5300	142.8	9.9	9500	134.6	18.8
1300	161.8	2.14	2200	156.3	3.75	3900	159.0	6.5	5400	161.9	8.9	9600	162.3	15.8
1300	175.9	1.97	2300	180.5	3.39	4000	183.7	5.8	5600	181.5	8.2	9900	181.5	14.5
1300	197.7	1.75	2300	205.2	2.99	4000	208.8	5.1	5600	207.1	7.2	10200	201.6	13.5
1300	216.6	1.60	2300	228.0	2.69	4000	232.0	4.59	5700	220.8	6.9	10200	236.0	11.5
1300	254.3	1.36	2300	256.5	2.39	4000	261.0	4.08	5700	253.8	6.0	10200	253.7	10.7
1300	282.6	1.23	2300	282.2	2.17	4000	287.1	3.71	5700	285.4	5.3	10200	285.2	9.5
1300	310.9	1.11	2300	308.3	1.99	4000	313.7	3.40	5700	315.2	4.82	10200	328.2	8.3
1300	350.6	0.99	2300	357.0	1.72	4000	363.3	2.93	5700	354.4	4.28	10200	365.1	7.4
			2300	393.8	1.56	4000	400.7	2.66	5700	419.2	3.62	10200	429.4	6.3

3.2 S.../C...组合型传动能力表

3.2 S.../C... Combi-type transmission capacity

S.../C... (iN=200-18000)

S.../C... (iN=200-18000)

公称输入转速	公称输出转速	公称减速比	公称减速比	额定输出扭矩	精确减速比	额定输入功率	额定输出扭矩	精确减速比	额定输入功率	额定输出扭矩	精确减速比	额定输入功率	额定输出扭矩	精确减速比	额定输入功率
Nominal Input Speed	Nominal Output Speed	Nominal Ratio Code	Nominal Ratio	Rated Output Torque	Exact Ratio	Rated Input Power	Rated Output Torque	Exact Ratio	Rated Input Power	Rated Output Torque	Exact Ratio	Rated Input Power	Rated Output Torque	Exact Ratio	Rated Input Power
n <sub>1N</sub> (r/min)	n <sub>2N</sub> (r/min)	Code	i <sub>N</sub>	T <sub>2N</sub> (N·m)	i <sub>ex</sub>	P <sub>1N</sub> (kW)	T <sub>2N</sub> (N·m)	i <sub>ex</sub>	P <sub>1N</sub> (kW)	T <sub>2N</sub> (N·m)	i <sub>ex</sub>	P <sub>1N</sub> (kW)	T <sub>2N</sub> (N·m)	i <sub>ex</sub>	P <sub>1N</sub> (kW)
1450	7.25	D20	200	100	190.1	0.14	180	203.3	0.24	310	217.9	0.38	540	210.9	0.68
	6.47	D22	224	100	212.5	0.13	180	227.3	0.21	310	237.0	0.35	540	229.4	0.63
	5.80	D25	250	100	225.7	0.12	180	241.5	0.20	310	266.3	0.31	540	257.7	0.56
	5.18	D28	280	100	255.8	0.10	180	273.6	0.18	310	300.8	0.27	540	291.1	0.49
	4.60	D32	315	100	302.0		180	323.0	0.15	310	333.8	0.25	540	323.1	0.45
	4.08	D36	355	100	336.6		180	360.1	0.13	310	382.5	0.22	540	370.3	0.39
	3.63	D40	400	100	376.2		180	402.4	0.12	310	420.0	0.20	540	406.6	0.35
	3.22	D45	450	100	399.3		180	427.1	0.11	310	472.5	0.17	540	457.4	0.31
	2.90	D50	500	100	475.2		180	508.3		310	506.3	0.16	540	490.1	0.29
	2.59	D56	560	100	544.5		180	582.5		310	573.8	0.14	540	555.4	0.26
	2.30	D63	630	100	620.4		180	663.6		310	648.8	0.13	540	628.0	0.23
	2.04	D71	710	100	673.2		180	720.1		310	738.8	0.11	540	715.1	0.20
	1.81	D80	800	100	732.6		180	783.7		310	832.5		540	805.9	0.18
	1.61	D90	900	100	811.8		180	868.4		310	945.0		540	914.8	0.16
	1.45	E10	1000	100	907.5		180	970.8		310	1009		540	976.5	0.15
	1.29	E11	1120	100	1066		180	1140		310	1136		540	1100	0.13
	1.16	E13	1250	100	1168		180	1250		310	1294		540	1252	0.11
	1.04	E14	1400	100	1267		180	1356		310	1466		540	1419	
	0.91	E16	1600	100	1528		180	1634		310	1658		540	1604	
	0.81	E18	1800	100	1709		180	1829		310	1785		540	1728	
	0.73	E20	2000	100	1815		180	1942		310	2089		540	2022	
	0.65	E22	2240	100	2234		180	2266		310	2205		540	2125	
	0.58	E25	2500	100	2423		180	2458		310	2498		540	2409	
	0.52	E28	2800	100	2922		180	2963		310	2824		540	2723	
	0.46	E32	3150	100	3269		180	3315		310	3042		540	2932	
	0.41	E36	3550	100	3471		180	3520		310	3559		540	3431	
	0.36	E40	4000	100	3836		181	3891		310	4038		540	3893	
	0.32	E45	4500	100	4499		182	4563		310	4447		540	4287	
	0.29	E50	5000	100	5111		183	5184		310	4863		540	4688	
	0.26	E56	5600	100	5515		184	5594		310	5316		540	5125	
	0.23	E63	6300							310	6096		540	6276	
	0.20	E71	7100							310	6891		540	7094	
	0.18	E80	8000							310	7421		540	7640	
	0.16	E90	9000							310	8684		540	8940	
	0.15	F10	10000							310	9853		540	10144	
	0.13	F11	11200							310	10851		540	11171	
	0.12	F13	12500							310	11864		540	12214	
	0.10	F14	14000							310	12971		540	13354	
	0.09	F16	16000												
	0.08	F18	18000												
	0.07	F20	20000												
	0.07	F22	22000												
	0.06	F25	25000												
	0.06	F28	28000												

额定输出扭矩	精确减速比	额定输入功率	额定输出扭矩	精确减速比	额定输入功率	额定输出扭矩	精确减速比	额定输入功率	额定输出扭矩	精确减速比	额定输入功率	额定输出扭矩	精确减速比	额定输入功率
Rated Output Torque	Exact Ratio	Rated Input Power	Rated Output Torque	Exact Ratio	Rated Input Power	Rated Output Torque	Exact Ratio	Rated Input Power	Rated Output Torque	Exact Ratio	Rated Input Power	Rated Output Torque	Exact Ratio	Rated Input Power
T <sub>2N</sub> (N·m)	i <sub>ex</sub>	P <sub>1N</sub> (kW)	T <sub>2N</sub> (N·m)	i <sub>ex</sub>	P <sub>1N</sub> (kW)	T <sub>2N</sub> (N·m)	i <sub>ex</sub>	P <sub>1N</sub> (kW)	T <sub>2N</sub> (N·m)	i <sub>ex</sub>	P <sub>1N</sub> (kW)	T <sub>2N</sub> (N·m)	i <sub>ex</sub>	P <sub>1N</sub> (kW)
S207/C203			S208/C205			S209/C205			S210/C207			S212/C208		
1300	200.4	1.73	2300	219.8	2.79									
1300	218.0	1.59	2300	245.8	2.49									
1300	245.0	1.41	2300	273.3	2.24	4000	273.3	3.90	5700	252.0	6.02	10200	258.1	10.53
1300	276.7	1.25	2300	300.8	2.04	4000	300.8	3.54	5700	287.0	5.29	10200	282.9	9.60
1300	307.1	1.13	2300	341.6	1.79	4000	341.6	3.12	5700	318.1	4.77	10200	326.6	8.32
1300	351.9	0.98	2300	364.2	1.68	4000	364.2	2.93	5700	363.6	4.18	10200	369.2	7.36
1300	386.4	0.90	2300	407.2	1.50	4000	407.2	2.62	5700	409.5	3.71	10200	401.2	6.77
						S210/C307								
1300	434.7	0.80	2300	452.4	1.35	4000	452.4	2.36	5700	444.8	3.41	10200	450.9	6.03
1300	465.8	0.74	2300	565.5	1.08	4000	565.5	1.88	5700	511.9	2.97	10200	493.5	5.51
			S207/C303											
1300	527.9	0.66	2300	618.3	0.99	4000	618.3	1.72	5700	543.6	2.79	10200	571.6	4.75
1300	596.9	0.58	2300	705.0	0.87	4000	705.0	1.51	5700	624.8	2.43	10200	610.6	4.45
						S212/C308								
1300	679.7	0.51	2300	750.2	0.82	4000	750.2	1.42	5700	730.7	2.08	10200	710.0	3.83
			S208/C305			S209/C305								
1300	765.9	0.45	2300	844.5	0.73	4000	844.5	1.26	5700	819.0	1.85	10200	784.6	3.46
1300	869.4	0.40	2300	950.0	0.64	4000	950.0	1.12	5700	935.5	1.62	10200	901.7	3.01
1300	928.1	0.37	2300	1071	0.57	4000	1071	1.00	5700	999.0	1.52	10200	1015	2.68
1300	1045	0.33	2300	1188	0.52	4000	1188	0.90	5700	1144	1.33	10200	1125	2.41
1300	1190	0.29	2300	1361	0.45	4000	1361	0.78	5700	1303	1.17	10200	1292	2.10
1300	1349	0.26	2300	1497	0.41	4000	1497	0.71	5700	1341	1.13	10200	1456	1.87
1300	1525	0.23	2300	1776	0.35	4000	1776	0.60	5700	1539	0.99	10200	1562	1.74
1300	1642	0.21	2300	1972	0.31	4000	1972	0.54	5700	1747	0.87	10200	1779	1.53
1300	1922	0.18	2300	2258	0.27	4000	2258	0.47	5700	1956	0.78	10200	1974	1.38
1300	2236	0.15	2300	2347	0.26	4000	2152	0.50	5700	2221	0.68	10200	2257	1.20
						S212/C307								
1300	2534	0.14	2300	2581	0.24	4000	2366	0.45	5700	2288	0.66	10200	2356	1.15
1300	2864	0.12	2300	3062	0.20	4000	2807	0.38	5700	2625	0.58	10200	2703	1.01
1300	3084	0.11	2300	3400	0.18	4000	3117	0.34	5700	2980	0.51	10200	3069	0.89
1300	3609		2300	3894	0.16	4000	3570	0.30	5700	3335	0.46	10200	3435	0.79
1300	4095		2300	4277	0.14	4000	3922	0.27	5700	3714	0.41	10200	3825	0.71
1300	4510		2300	4823	0.13	4000	4422	0.24	5700	4082	0.37	10200	4204	0.65
1300	4931		2300	5155	0.12	4000	4726	0.23	5700	4635	0.33	10200	4774	0.57
1300	5391		2300	5993	0.10	4000	5495	0.19	5700	5767	0.26	10200	5940	0.46
1300	6326		2300	6205		4000	6312	0.17	5700	6152	0.25	10200		

### 4 允许的径向力

4.1 输入轴径向力Fr1表(N)

### 4 Permissible Radial Force

4.1 Radial force on input shaft (Fr1) (N)

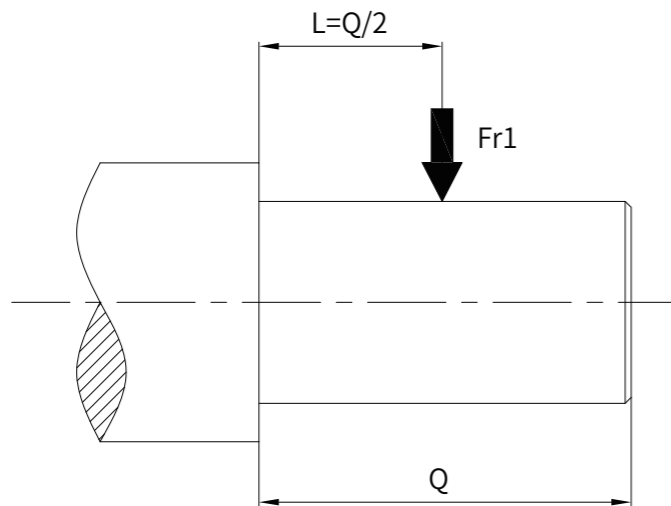

	Fr1 (N)								
	S203	S204	S205	S206	S207	S208	S209	S210	S212
AE2	803	803	803	803	803	803	/	/	/
AE3	/	/	1504	1504	1504	1504	1504	1504	/
AE4	/	/	/	/	2188	2188	2188	2188	2188
AE5	/	/	/	/	/	/	4207	4207	4207
AE6	/	/	/	/	/	/	/	5664	5664
AE7	/	/	/	/	/	/	/	/	9957

4.2 输出轴径向力Fr2表(N)

4.2 Radial force on output shaft (Fr2) (N)

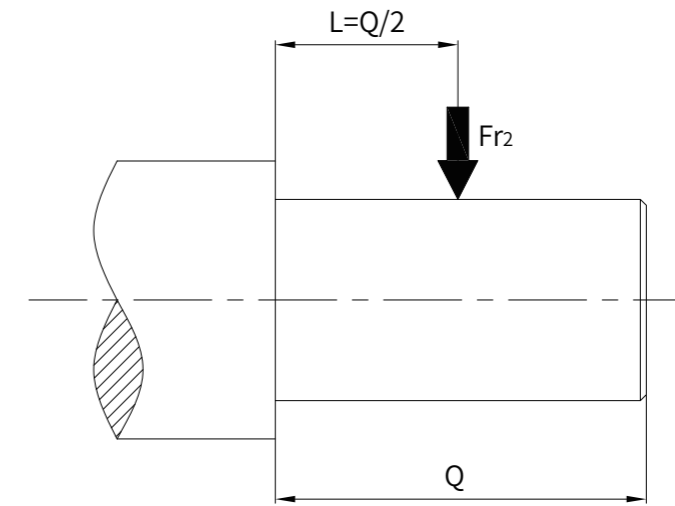

n <sub>2N</sub> (r/min)	Fr2 (N)								
	S203	S204	S205	S206	S207	S208	S209	S210	S212
200~224	370	520	860	860	870	3170	3620	5190	7270
180~200	460	650	1080	1070	1090	3960	4530	6490	9090
160~180	580	810	1350	1340	1360	4950	5660	8110	11360
125~160	720	1010	1680	1670	1700	6190	7070	10140	14200
112~125	900	1270	2110	2090	2120	7740	8840	12680	17760
100~112	1120	1580	2630	2610	2650	9680	11050	15850	22200
90~100	1400	1980	3290	3270	3310	12100	13820	19810	27740
80~90	1760	2480	4110	4090	4140	15120	17270	24760	34680
56~80	2151	3035	5041	5007	5075	18530	21165	30345	42500
45~56	2380	3332	5542	5304	6265	20995	24650	35275	47600
40~45	2380	3502	5814	5559	6571	22100	25840	36975	49725
35.5~40	2550	3502	5950	6163	6919	23035	26605	38063	51255
31.5~35.5	2550	3766	6222	6163	7438	23970	27880	39950	53720
28~31.5	2550	4004	6392	6851	7659	24650	28985	41565	56100
26.5~28	2550	4123	6392	6851	8203	24650	29325	43095	60350
22.4~26.5	2550	4522	6392	7370	9860	24650	29325	43095	60350
≤22.4	2550	4556	6392	7378	10455	24650	29325	43095	60350

5 外形尺寸图表

5.1 S203~S212+MP

5 Dimensions

5.1 S203~S212+MP

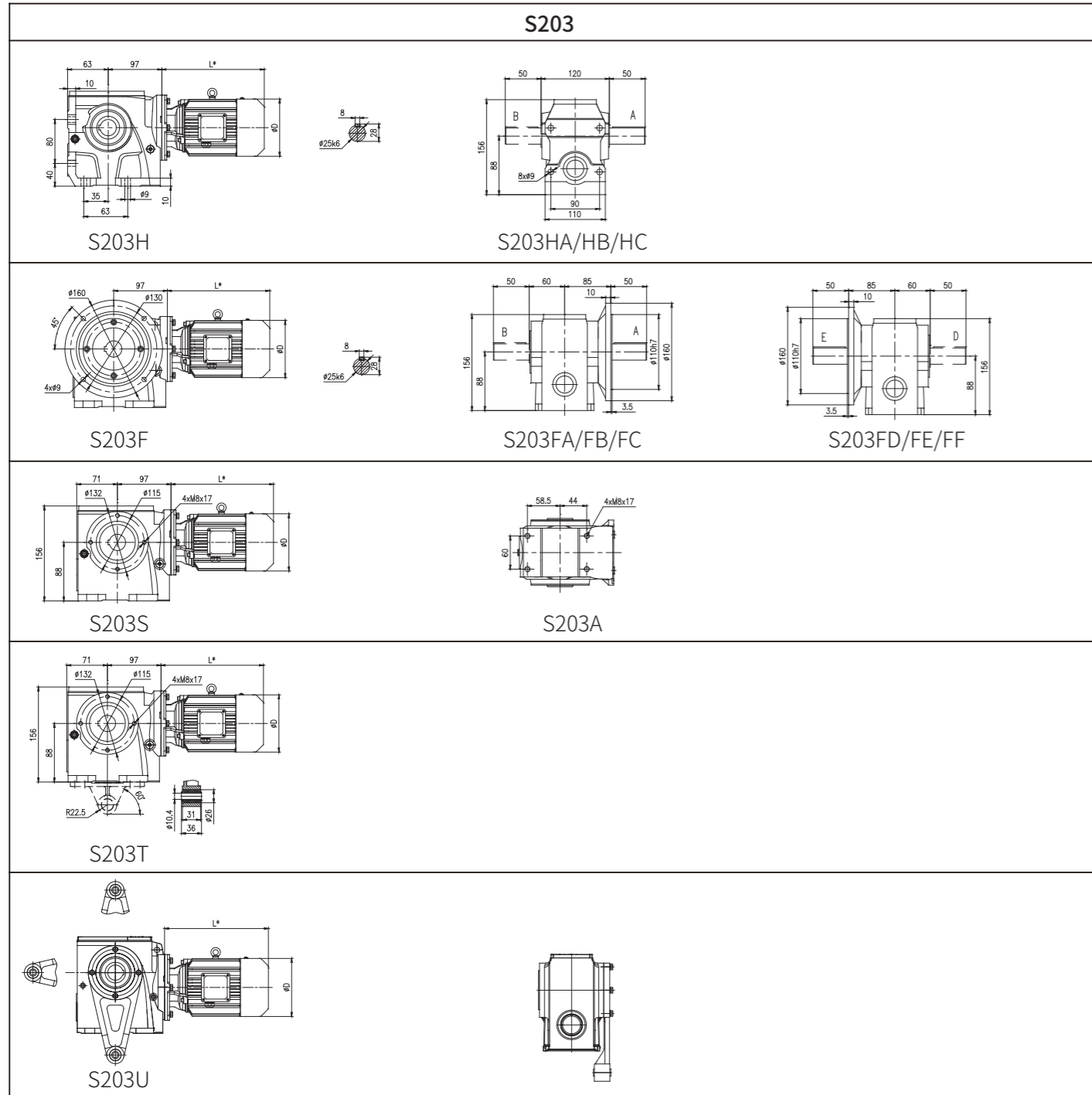

MP motor dimension for S203

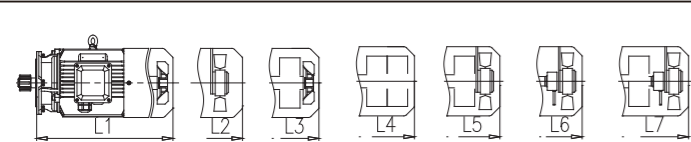

P <sub>i</sub> /kW	i <sub>n</sub>	MP							D
		L1	L2	L3	L5	L6	L7		
0.12	7.1-180	206	261	241	296	/	/	124	
0.18	7.1-180	206	261	241	296	/	/	124	
0.25	7.1-100	223	268	263	313	313	353	139	
0.37	7.1-63	223	268	263	313	313	353	139	
0.55	7.1-35.5	299	344	359	404	404	454	162	
0.75	7.1-25	299	344	359	404	404	454	162	

注: 渐开线花键空心轴的花键规格DIN5480: m1.25×z18×α30×D25×9H

Note: Involute spline size DIN5480: m1.25×z18×α30×D25×9H

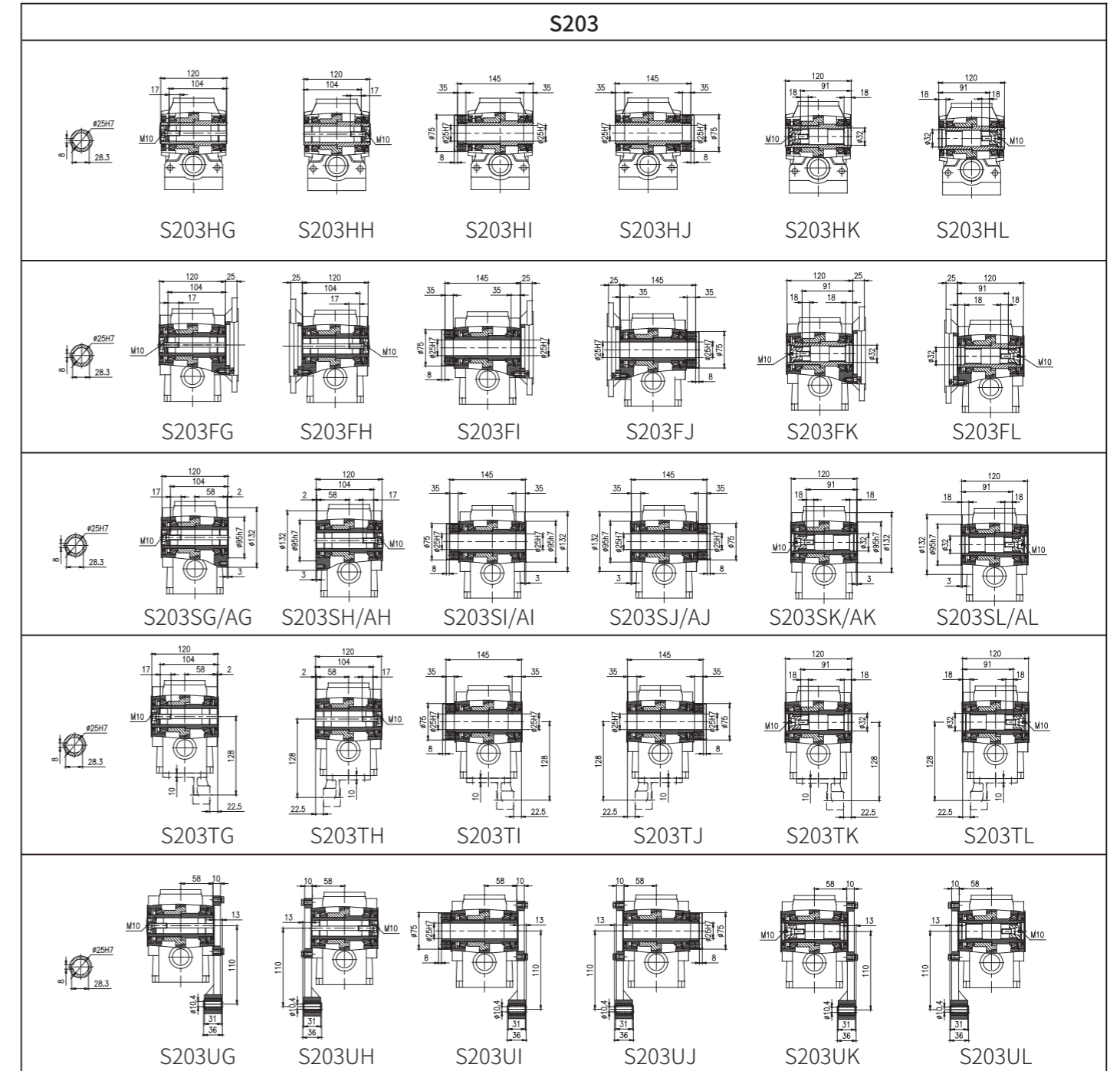

S203/C.01

MP motor dimension for S203/C.01

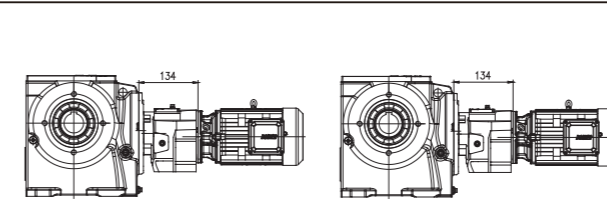

P <sub>i</sub> /kW	i <sub>n</sub>	MP							D
		L1	L2	L3	L5	L6	L7		
0.12	200-355	206	/	241	/	/	/	124	
0.18	200-250	206	/	241	/	/	/	124	

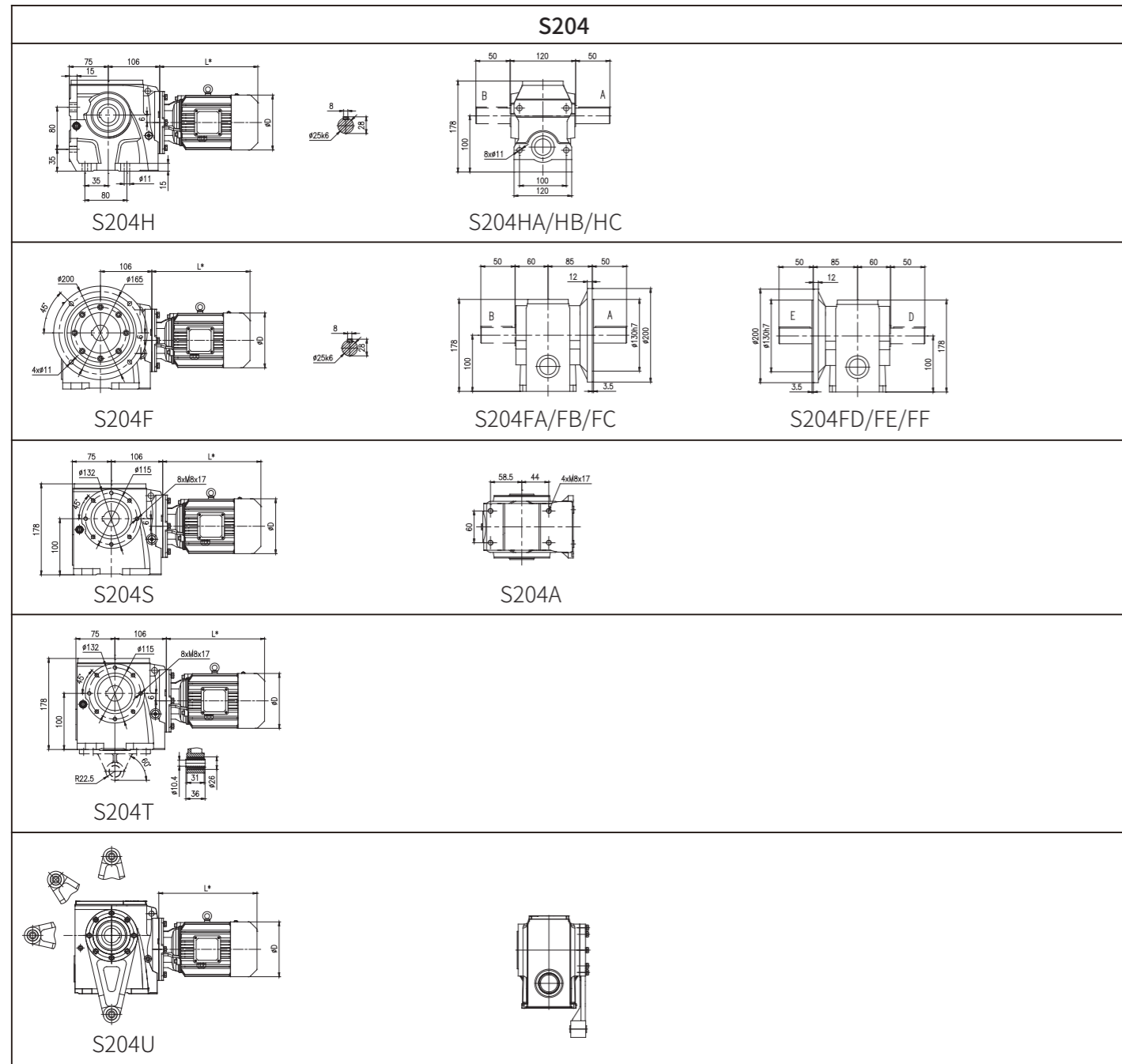

MP motor dimension for S204

MP motor dimension for S204	P <sub>1</sub> /kW	i <sub>N</sub>	MP							D
			L1	L2	L3	L5	L6	L7		
	0.12	7.1-224	206	261	241	296	/	/	124	
	0.18	7.1-224	206	261	241	296	/	/	124	
	0.25	7.1-224	224	268	263	313	313	353	139	
	0.37	7.1-140	224	268	263	313	313	353	139	
	0.55	7.1-90	300	344	359	404	404	454	162	
	0.75	7.1-63	300	344	359	404	404	454	162	
	1.1	7.1-35.5	323	367	377	422	422	477	176	
	1.5	7.1-20	347	392	402	447	447	502	176	

注:渐开线花键空心轴的花键规格DIN5480: m1.25×z18×α30×D25×9H

Note: Involute spline size DIN5480: m1.25×z18×α30×D25×9H

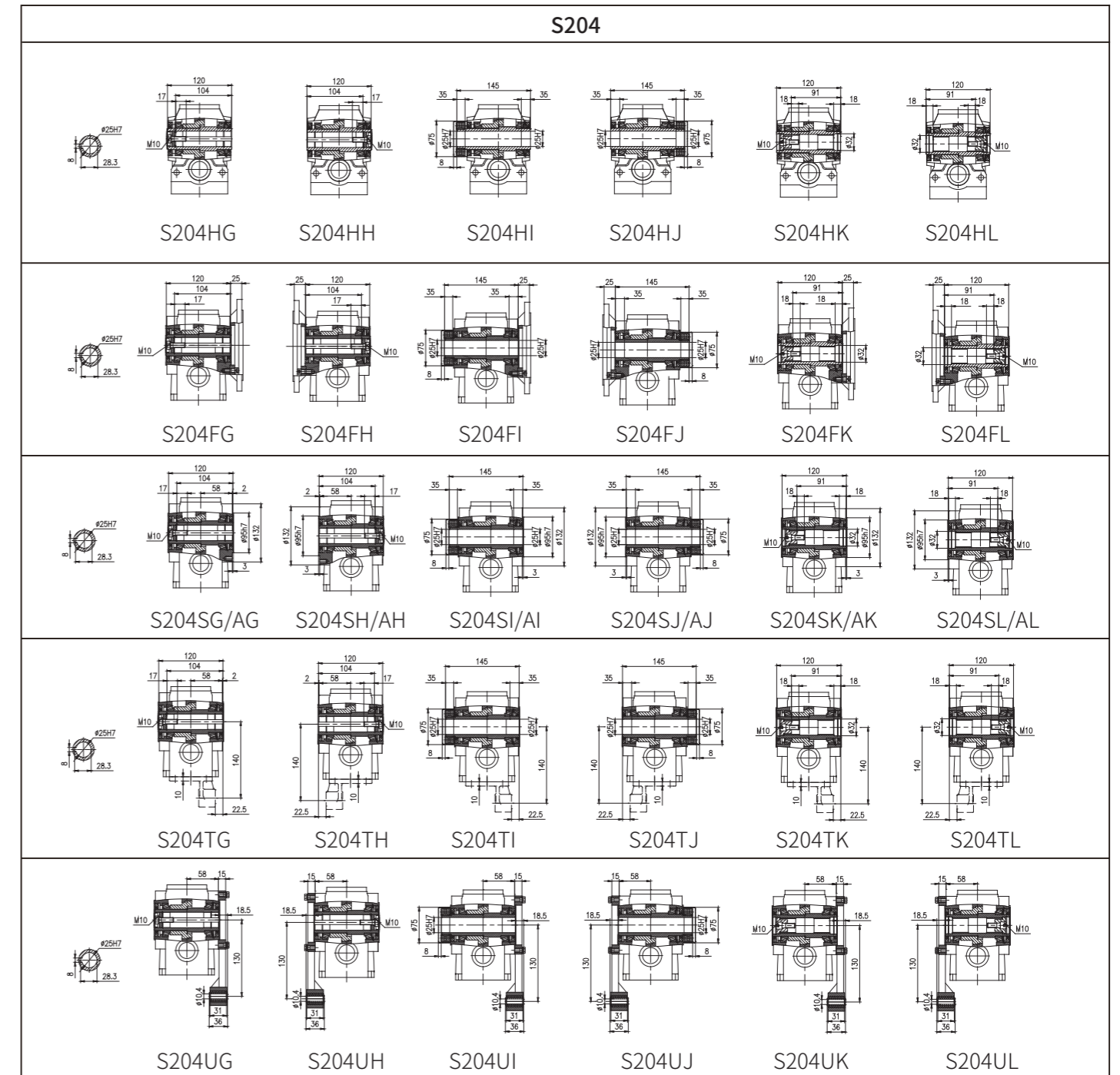

S204/C.01

MP motor dimension for S204/C.01

S204/C.01	MP motor dimension for S204/C.01	P <sub>1</sub> /kW	i <sub>N</sub>	MP							D
				L1	L2	L3	L5	L6	L7		
		0.12	200-630	206	/	241	/	/	/	124	
		0.18	200-400	206	/	241	/	/	/	124	
		0.25	200-280	228	/	263	/	/	/	139	

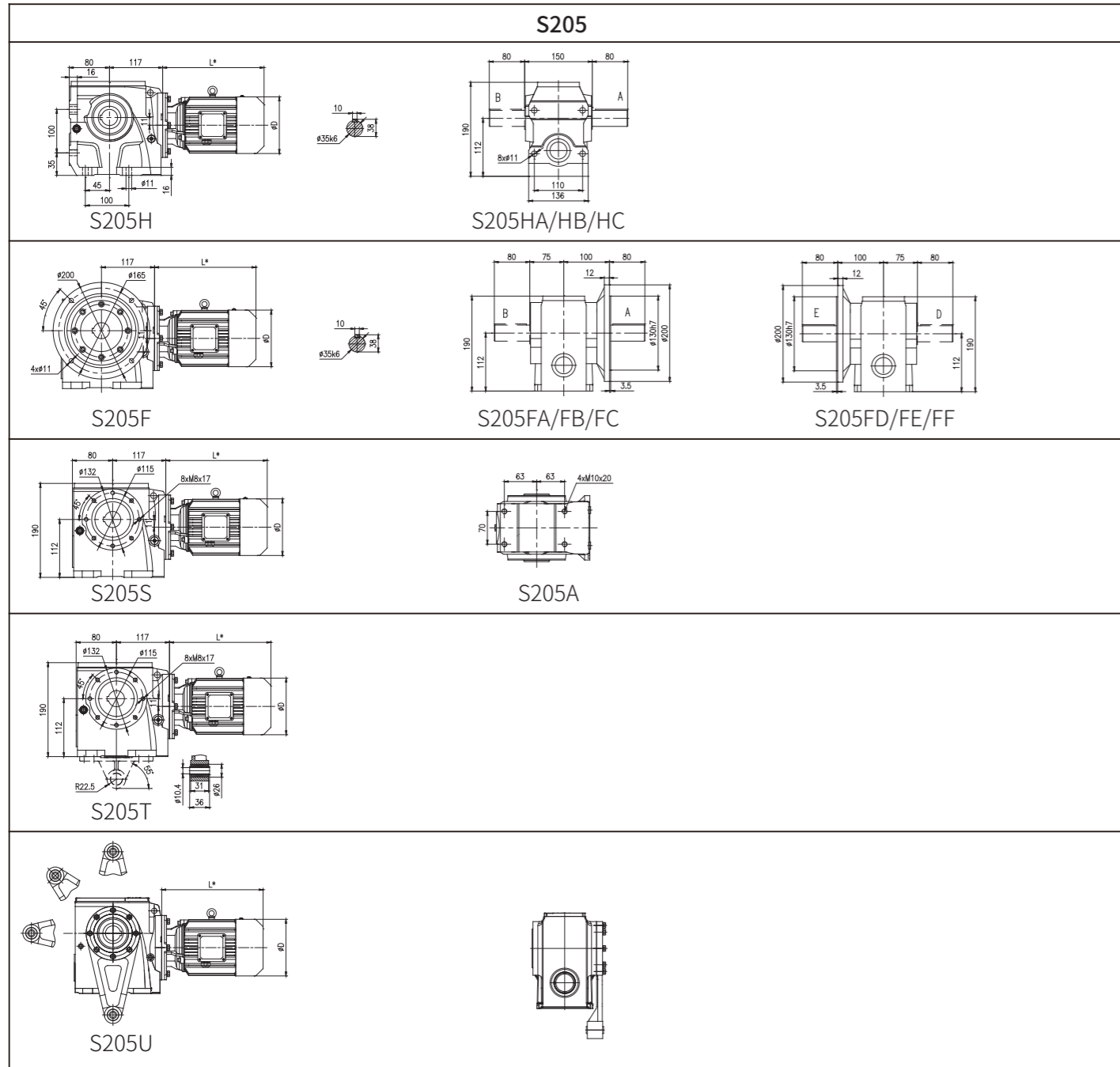

MP motor dimension for S205

MP	P <sub>i</sub> /kW	i <sub>n</sub>	MP							D
			L1	L2	L3	L5	L6	L7		
Fan	0.12	8-224	207	262	242	297	/	/	124	
Driven fan	0.18	8-224	207	262	242	297	/	/	124	
Brake + fan	0.25	8-224	224	269	264	314	314	354	139	
Double brake	0.37	8-224	224	269	264	314	314	354	139	
Brake + Driven fan	0.55	8-180	300	345	360	405	405	455	162	
Encoder + Driven fan	0.75	8-125	300	345	360	405	405	455	162	
Brake + Encoder + Driven fan	1.1	8-80	323	368	378	423	423	478	176	
	1.5	8-40	348	393	403	448	448	503	176	
	2.2	8-25	395	435	470	510	510	565	202	

注:渐开线花键空心轴的花键规格DIN5480: m2×z16×α30×D35×9H Note: Involute spline size DIN5480: m2×z16×α30×D35×9H

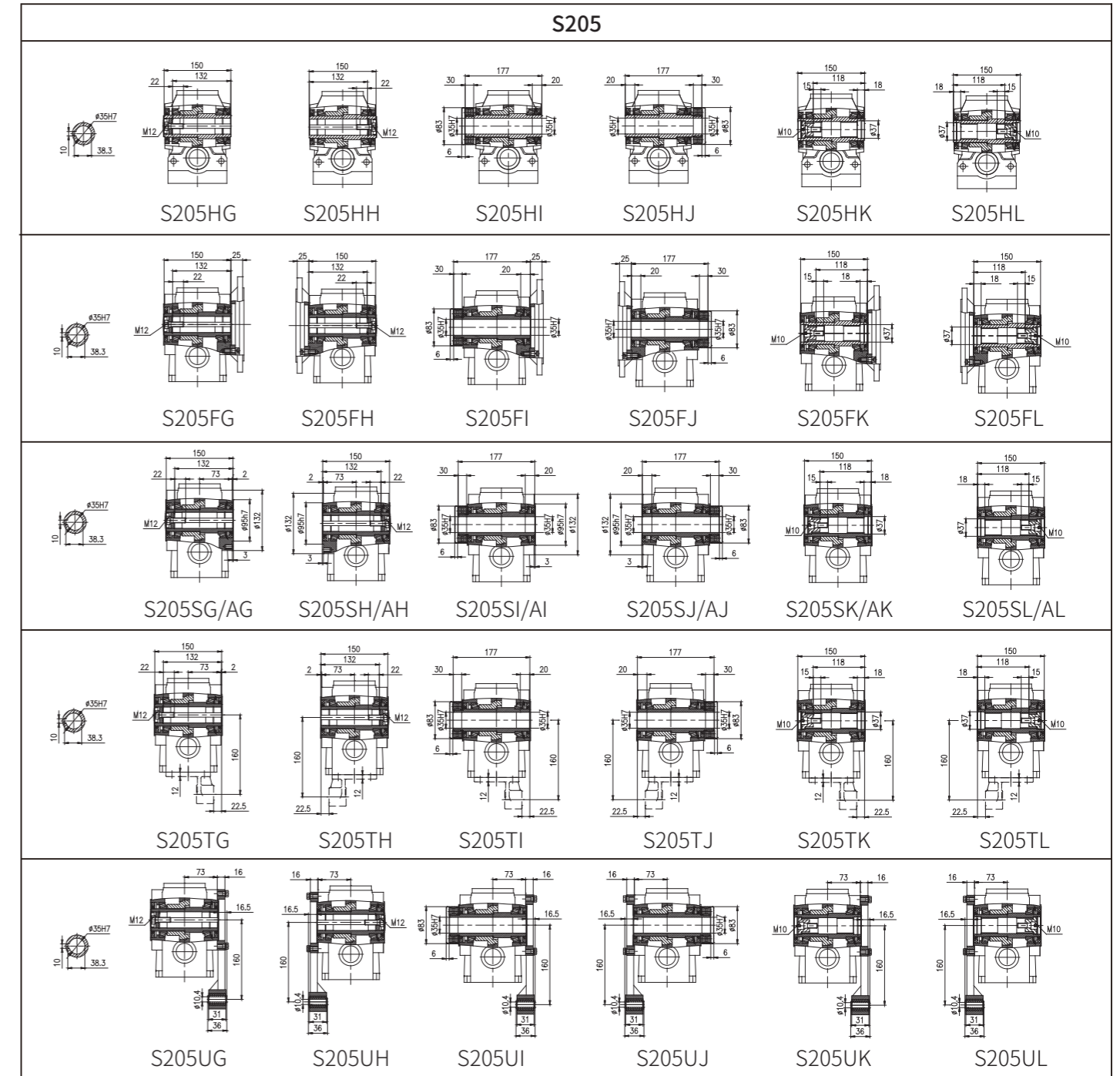

S205/C.03

MP motor dimension for S205/C.03

MP	P <sub>i</sub> /kW	i <sub>n</sub>	MP							D
			L1	L2	L3	L5	L6	L7		
S205/C203	0.12	200-1120	206	261	241	296	/	/	124	
S205/C303	0.18	200-710	206	261	241	296	/	/	124	
	0.25	200-500	223	268	263	313	313	353	139	
	0.37	200-315	223	268	263	313	313	353	139	

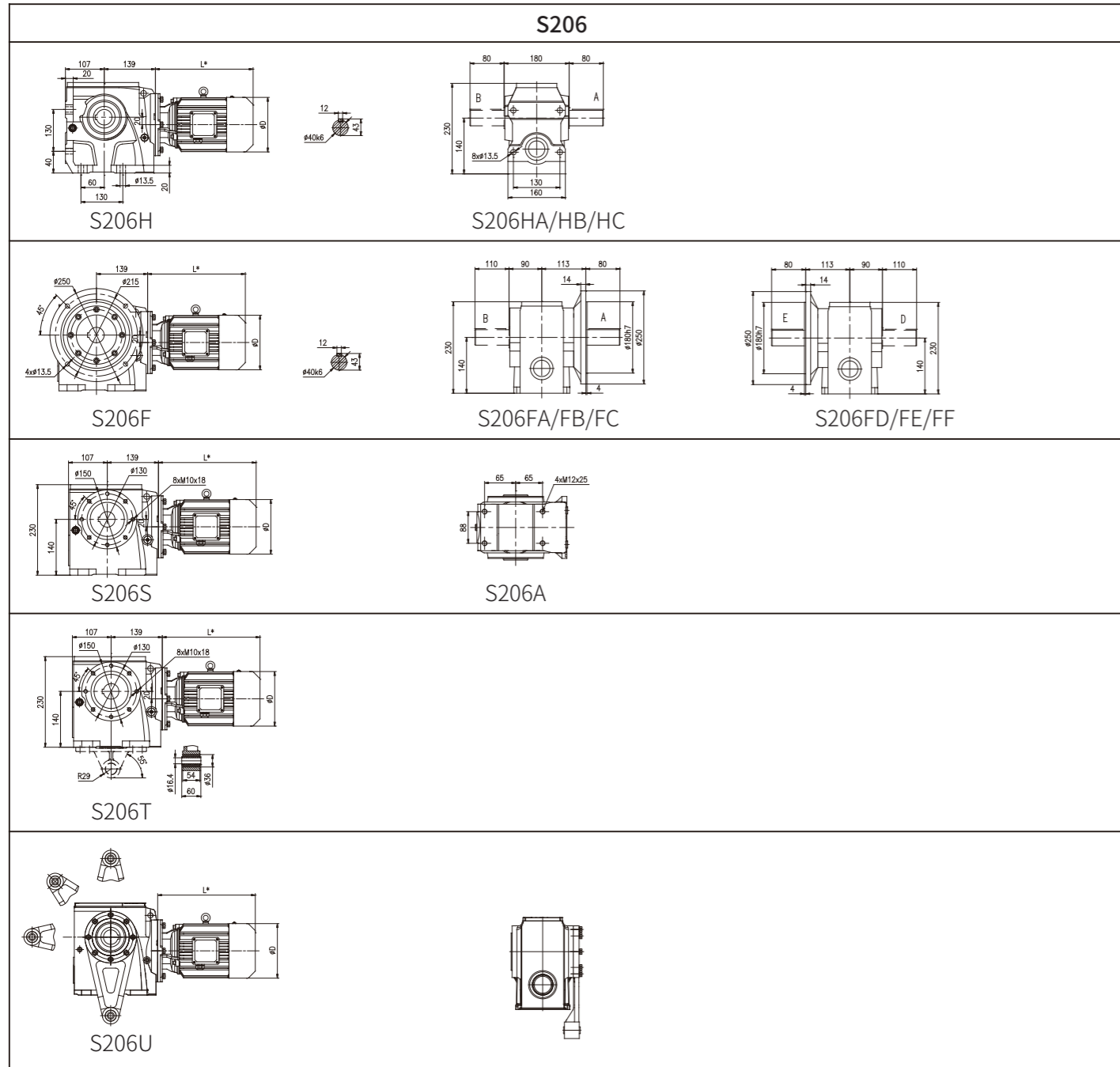

MP motor dimension for S206

MP	P <sub>i</sub> /kW	i <sub>N</sub>	MP							D
			L1	L2	L3	L5	L6	L7		
Fan	0.18	180-315	207	262	242	297	/	/	124	
Driven fan	0.25	125-315	224	269	264	314	314	354	139	
Brake + fan	0.37	80-315	224	269	264	314	314	354	139	
Double brake	0.55	50-280	300	345	360	405	405	455	162	
Brake + Driven fan	0.75	28-224	300	345	360	405	405	455	162	
Brake + Encorder	1.1	18-140	323	368	378	423	423	478	176	
Encorder + Driven fan	1.5	10-100	348	393	403	448	448	503	176	
Brake + Encorder + Driven fan	2.2	7.1-71	395	435	470	510	510	565	202	
	3	7.1-40	395	435	470	510	510	565	202	
	4	7.1-25	459	509	534	584	584	639	220	

注:渐开线花键空心轴的花键规格DIN5480: m2×z16×α30×D35×9H

Note: Involute spline size DIN5480: m2×z16×α30×D35×9H

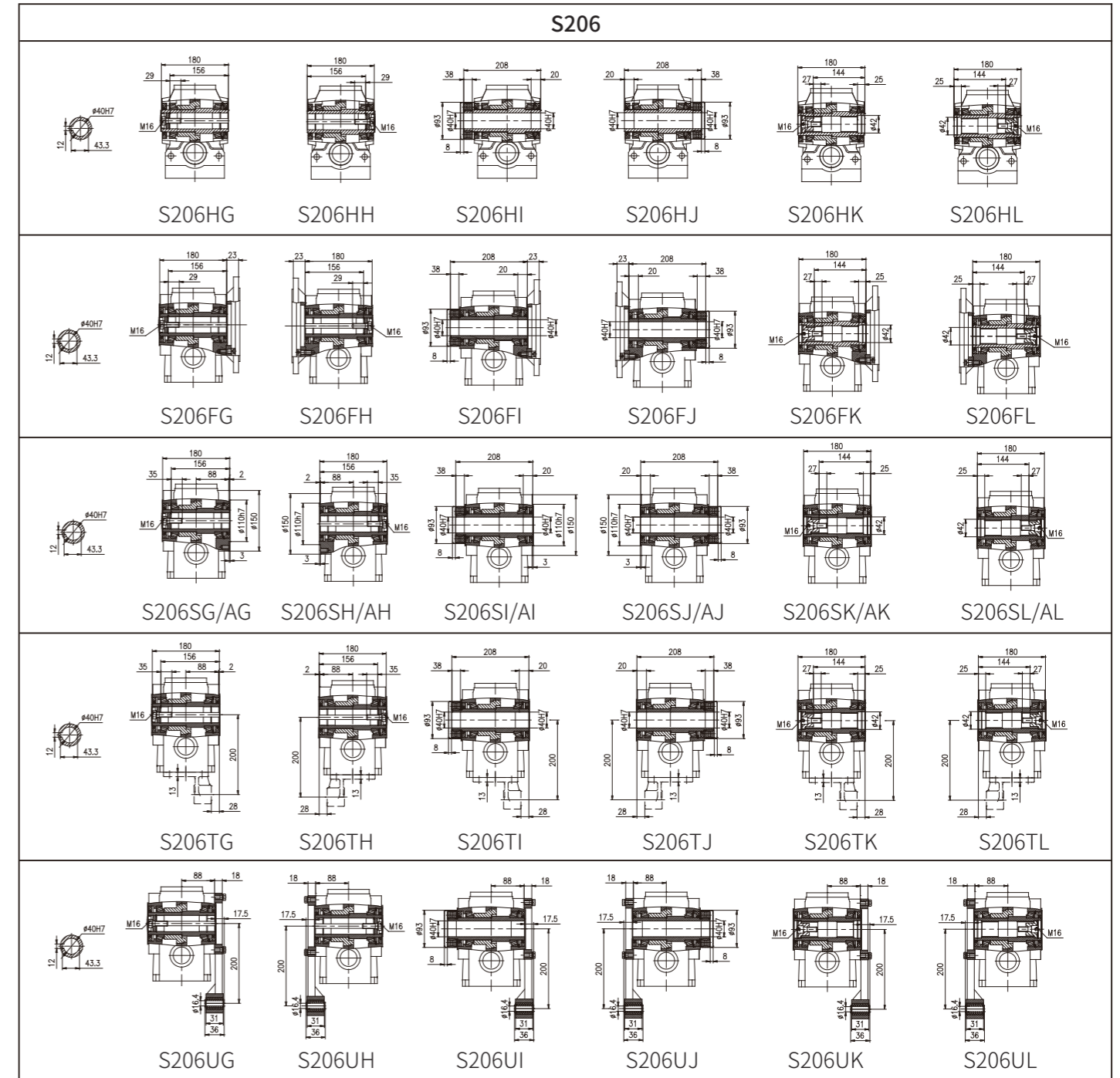

S206/C.03

MP motor dimension for S206/C.03

MP	P <sub>i</sub> /kW	i <sub>N</sub>	MP							D
			L1	L2	L3	L5	L6	L7		
S206/C203	0.12	200-1800	206	261	241	296	/	/	124	
S206/C303	0.18	200-1250	206	261	241	296	/	/	124	
	0.25	200-900	223	268	263	313	313	353	139	
	0.37	200-630	223	268	263	313	313	353	139	
	0.55	200-400	299	344	359	404	404	454	162	
	0.75	200-280	299	344	359	404	404	454	162	

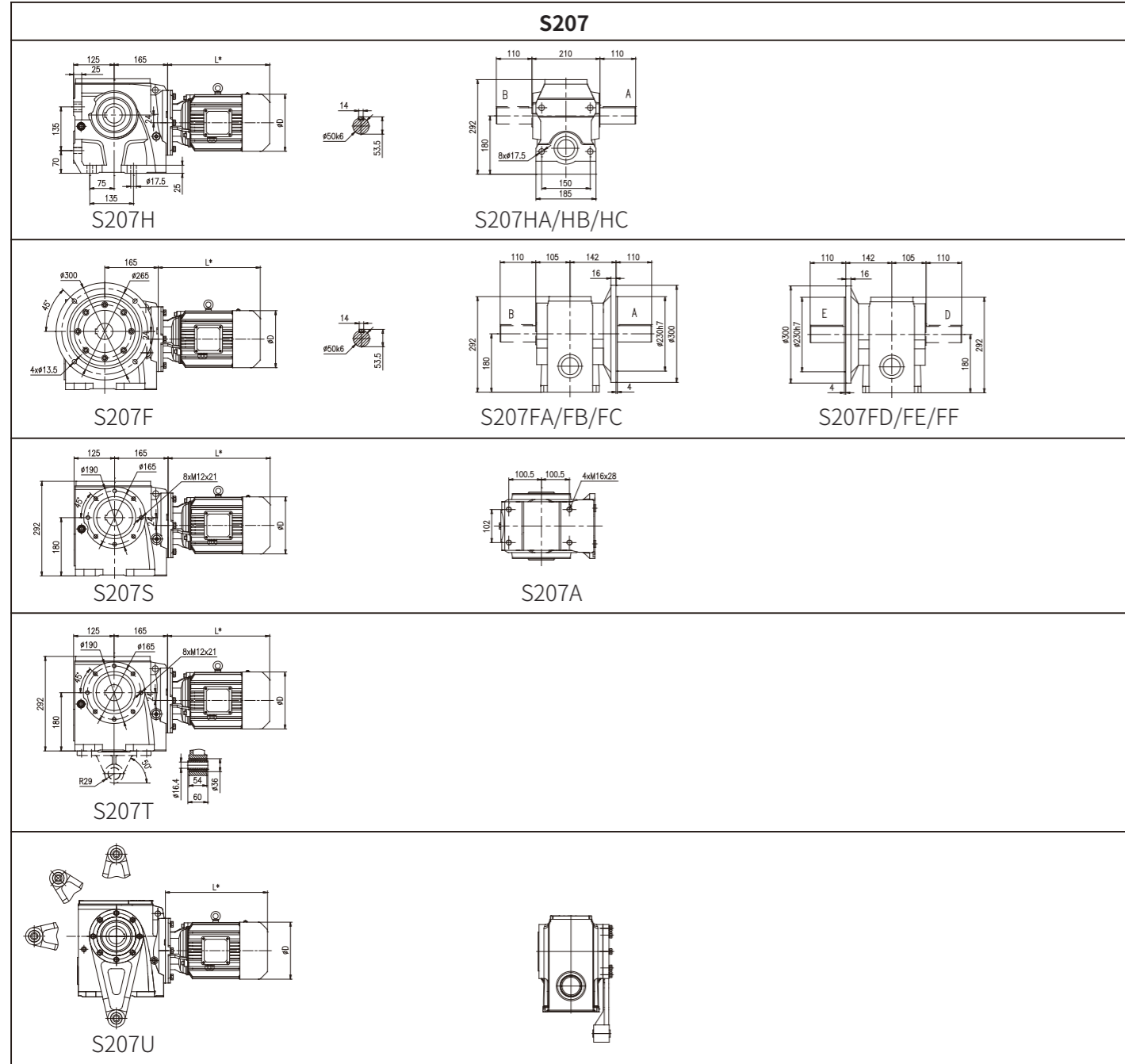

MP motor dimension for S207

MP	P <sub>i</sub> /kW	i <sub>n</sub>	MP							D
			L1	L2	L3	L5	L6	L7		
0.37	224-355	216	261	256	306	306	346	139		
0.55	140-355	292	337	352	397	397	447	162		
0.75	80-355	292	337	352	397	397	447	162		
1.1	50-250	315	360	370	415	415	470	176		
1.5	35.5-250	340	385	395	440	440	495	176		
2.2	22.4-200	387	427	462	502	502	557	202		
3	11.2-125	387	427	462	502	502	557	202		
4	8-80	451	501	526	576	576	631	220		
5.5	8-40	459	509	539	584	584	639	259		
7.5	8-35.5	497	547	577	622	622	677	259		

注: 渐开线花键空心轴的花键规格DIN5480: m2×z24×α30×D50×9H  
 Note: Involute spline size DIN5480: m2×z24×α30×D50×9H

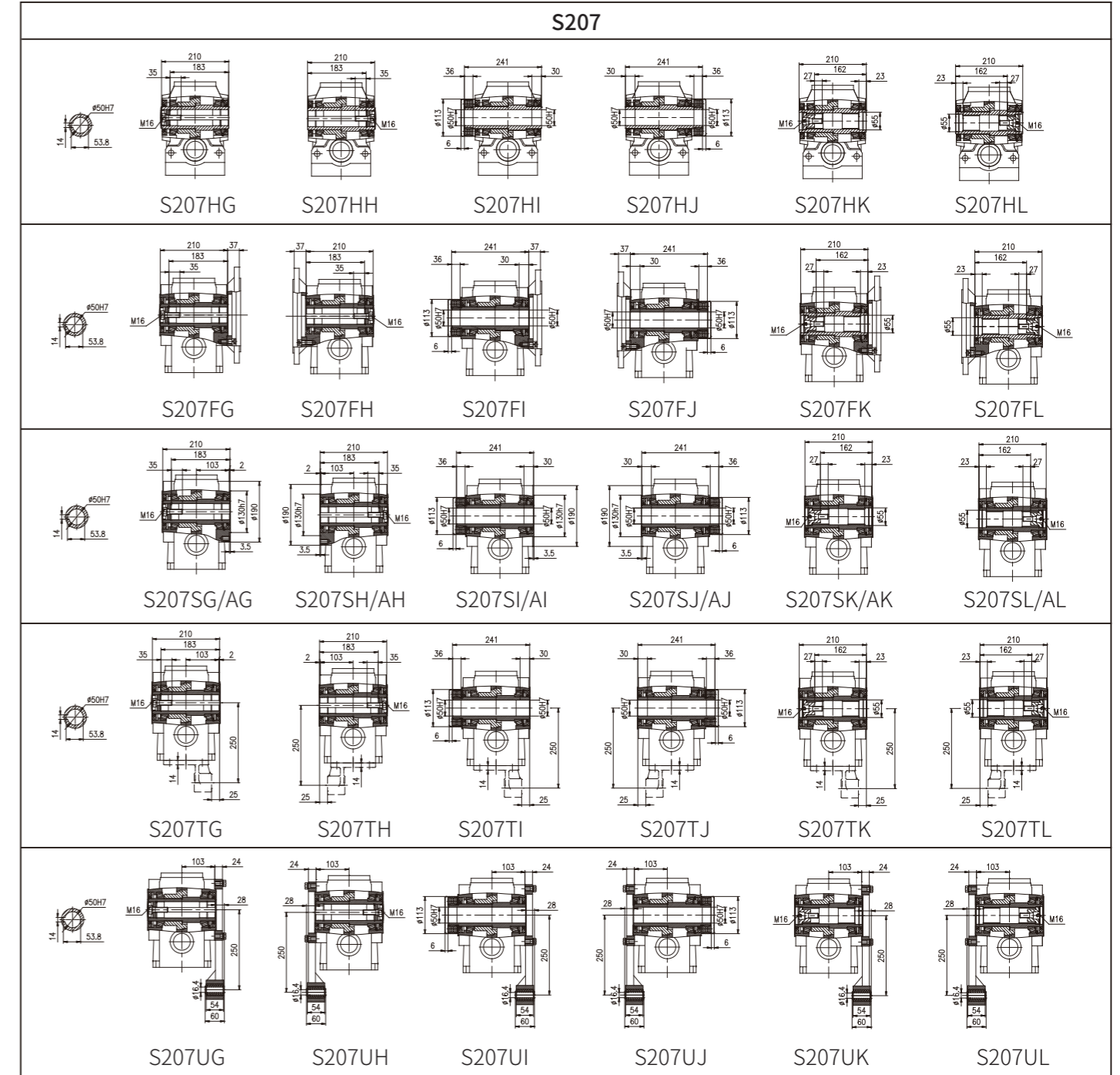

S207/C.03

MP motor dimension for S207/C.03

MP	P <sub>i</sub> /kW	i <sub>n</sub>	MP							D
			L1	L2	L3	L5	L6	L7		
0.12	200-4500	206	261	241	296	/	/	124		
0.18	200-3150	206	261	241	296	/	/	124		
0.25	200-2240	223	268	263	313	313	353	139		
0.37	200-1600	223	268	263	313	313	353	139		
0.55	200-1120	299	344	359	404	404	454	162		
0.75	200-800	299	344	359	404	404	454	162		
1.1	200-500	322	367	377	422	422	477	176		
1.5	200-355	347	392	402	447	447	502	176		
2.2	200-250	394	434	469	509	509	564	202		

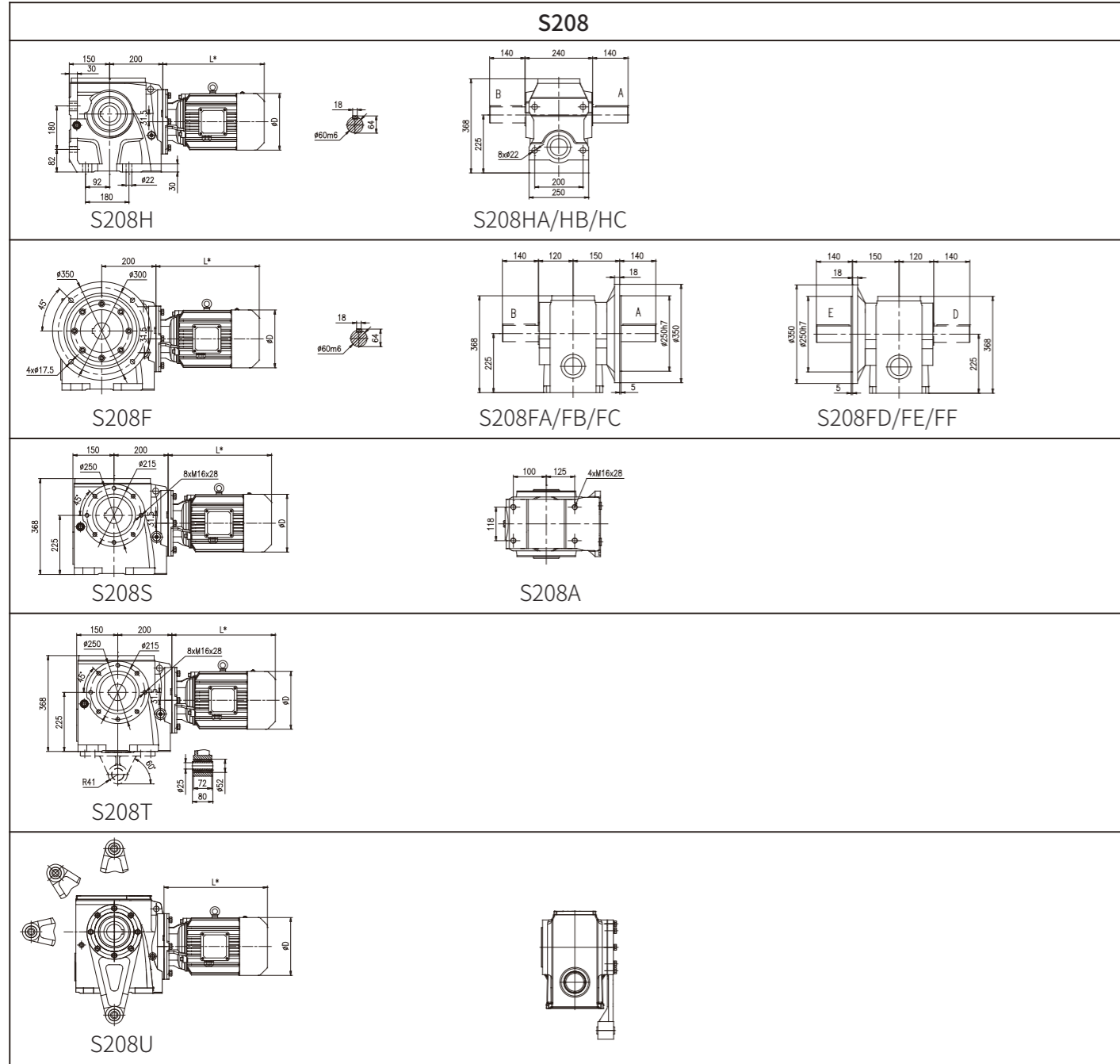

MP motor dimension for S208

MP motor dimension for S208	P <sub>1</sub> /kW	i <sub>N</sub>	MP							D
			L1	L2	L3	L5	L6	L7		
	0.55	250-500	283	328	343	388	388	438	162	
	0.75	180-500	283	328	343	388	388	438	162	
	1.1	100-315	306	351	361	406	406	461	176	
	1.5	50-315	331	376	386	431	431	486	176	
	2.2	31.5-315	378	418	453	493	493	548	202	
	3	25-250	378	418	453	493	493	548	202	
	4	12.5-180	442	492	517	567	567	622	220	
	5.5	10-100	451	501	531	576	576	631	259	
	7.5	10-50	489	539	569	614	614	669	259	
	11	10-31.5	550	585	645	675	675	725	314	
	15	10-25	580	615	675	705	705	755	314	

注:渐开线花键空心轴的花键规格DIN5480: m2×z31×α30×D65×9H  
 Note: Involute spline size DIN5480: m2×z31×α30×D65×9H

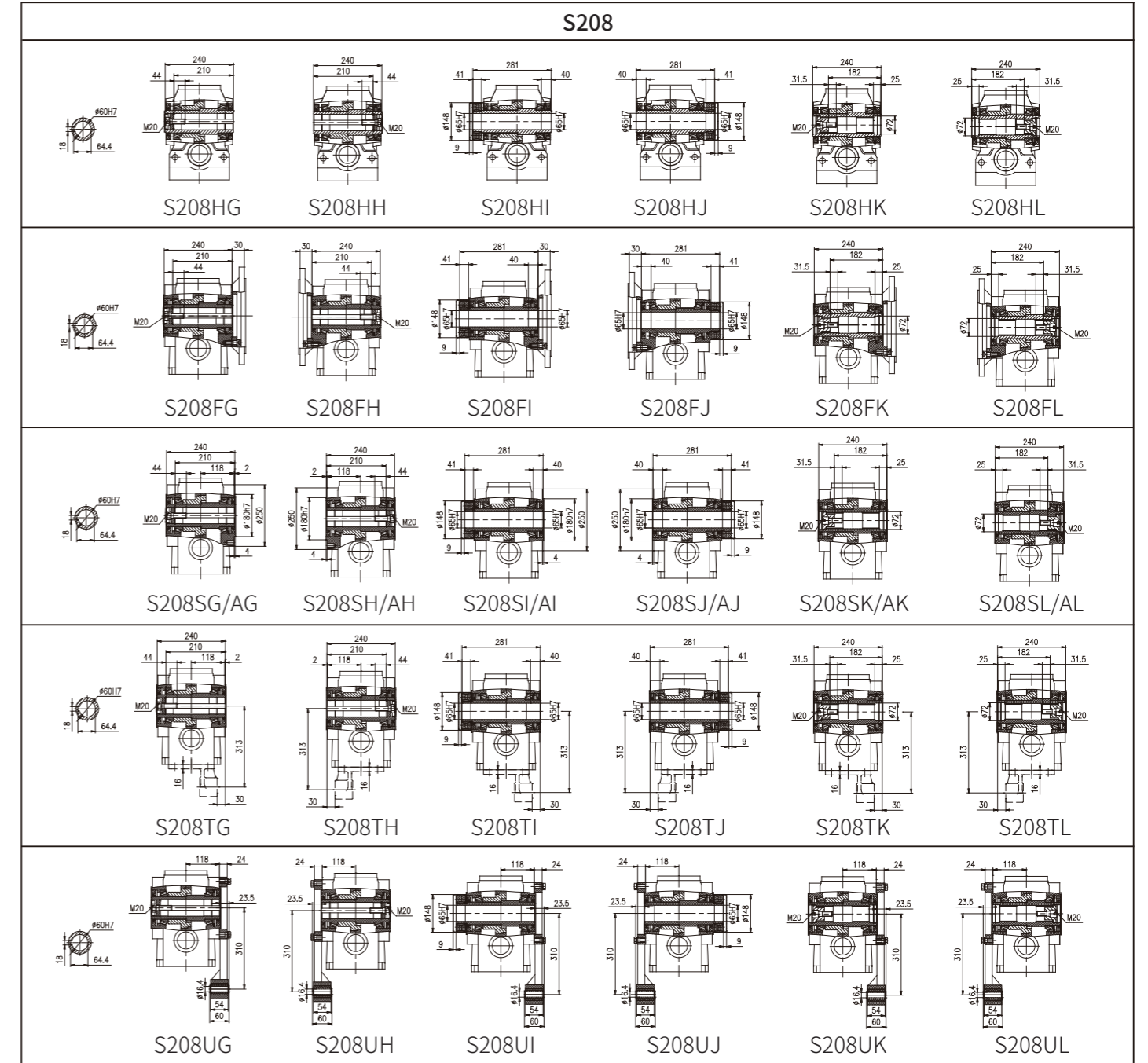

S208/C.05

MP motor dimension for S208/C.05

S208/C.05	P <sub>1</sub> /kW	i <sub>N</sub>	MP							D
			L1	L2	L3	L5	L6	L7		
	0.12	200-8000	206	261	241	296	/	/	124	
	0.18	200-5000	206	261	241	296	/	/	124	
	0.25	200-3550	223	268	263	313	313	353	139	
	0.37	200-2500	223	268	263	313	313	353	139	
	0.55	200-1600	299	344	359	404	404	454	162	
	0.75	200-1250	299	344	359	404	404	454	162	
	1.1	200-800	322	367	377	422	422	477	176	
	1.5	200-560	347	392	402	447	447	502	176	
	2.2	200-450	394	434	469	509	509	564	202	
	3	200-280	394	434	469	509	509	564	202	

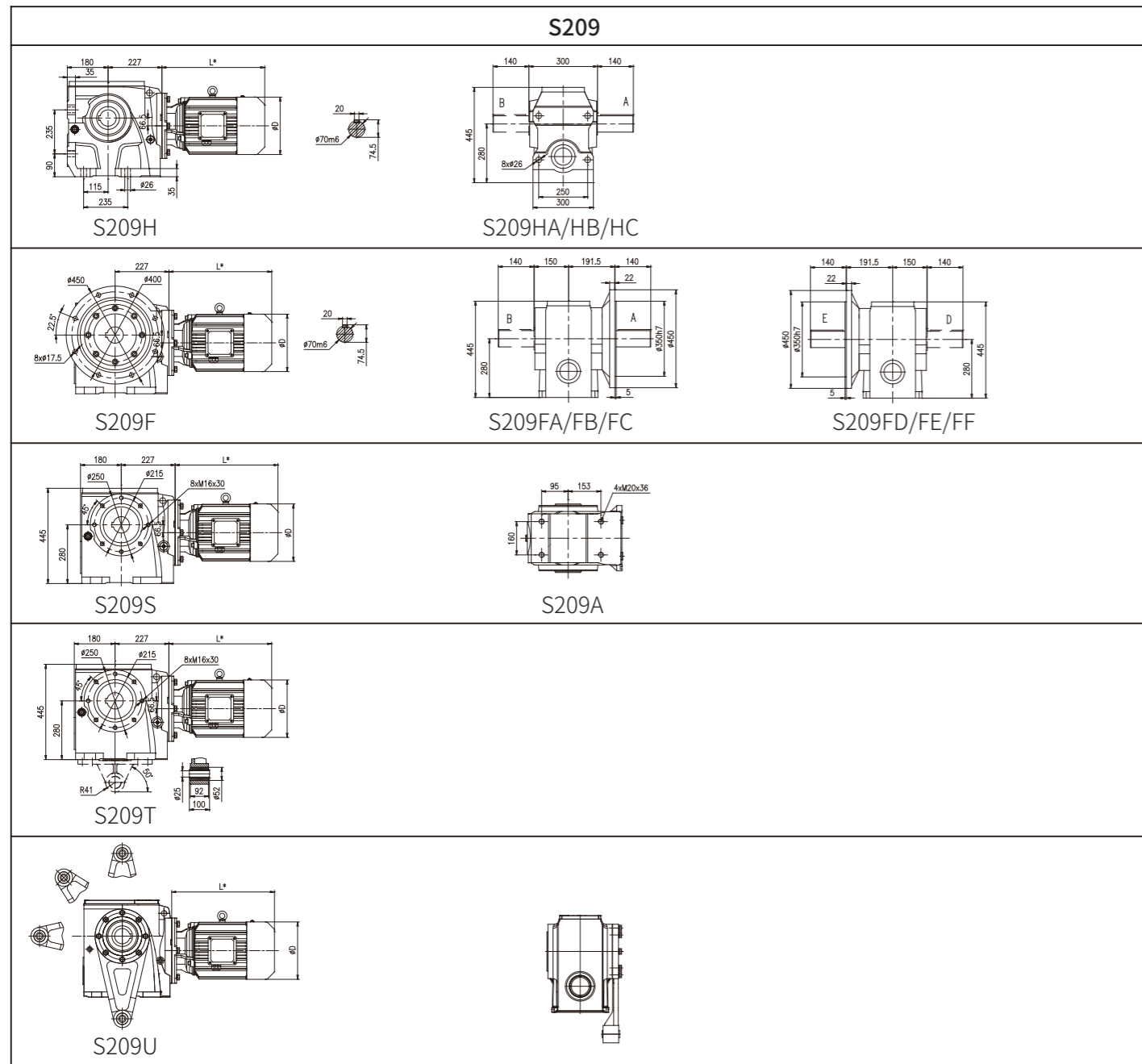

MP motor dimension for S209

MP	P <sub>i</sub> /kW	i <sub>n</sub>	MP							D
			L1	L2	L3	L5	L6	L7		
Fan	0.75	315-500	280	325	340	385	385	435	162	
Driven fan	1.1	224-315	303	348	358	403	403	458	176	
Brake + fan	1.5	160-315	328	373	383	428	428	483	176	
Double brake	2.2	90-315	374	414	449	489	489	544	202	
Brake + Driven fan	3	63-315	374	414	449	489	489	544	202	
Encoder + Driven fan	4	40-315	438	488	513	563	563	618	220	
Brake + Encoder + Driven fan	5.5	20-160	450	500	530	575	575	630	259	
	7.5	18-160	488	538	568	613	613	668	259	
	11	18-90	544	579	639	669	669	719	314	
	15	18-63	574	609	669	699	699	749	314	
	18.5	18-40	615	645	725	750	750	795	356	
	22	18-31.5	663	693	773	798	798	843	356	

注:渐开线花键空心轴的花键规格DIN5480: m2×z34×α30×D70×9H Note: Involute spline size DIN5480: m2×z34×α30×D70×9H

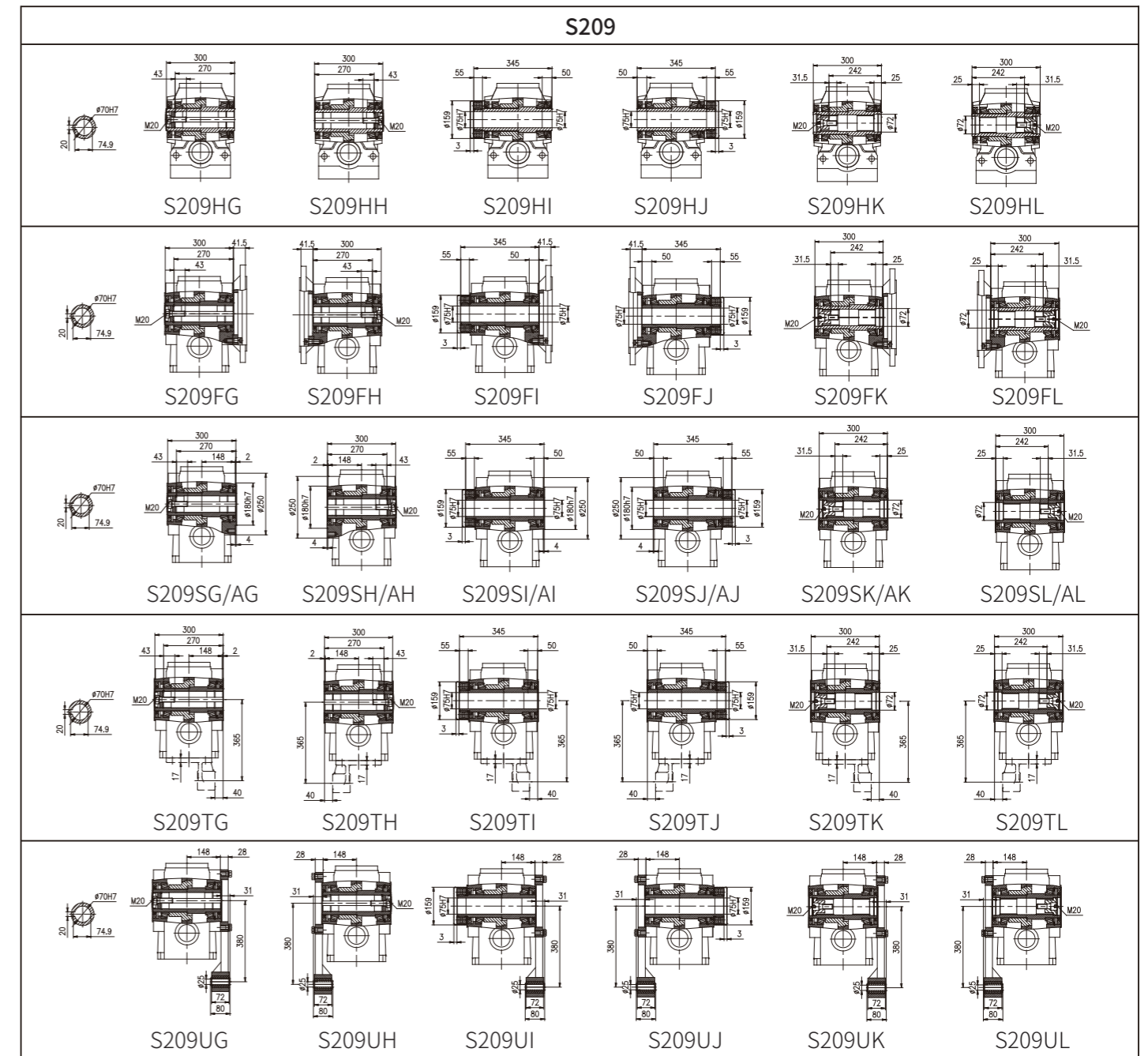

MP	P <sub>i</sub> /kW	i <sub>n</sub>	MP							D
			L1	L2	L3	L5	L6	L7		
S209/C.05	0.12	250-14000	207	262	242	297	/	/	124	
S209/C305	0.18	250-9000	207	262	242	297	/	/	124	
	0.25	250-6300	224	269	264	314	314	354	139	
	0.37	250-5000	224	269	264	314	314	354	139	
	0.55	250-3150	300	345	360	405	405	455	162	
	0.75	250-2500	300	345	360	405	405	455	162	
	1.1	250-1400	323	368	378	423	423	478	176	
	1.5	250-1000	348	393	403	448	448	503	176	
	2.2	250-710	395	435	470	510	510	565	202	
	3	250-500	395	435	470	510	510	565	202	
	4	250-400	459	509	534	584	584	639	220	

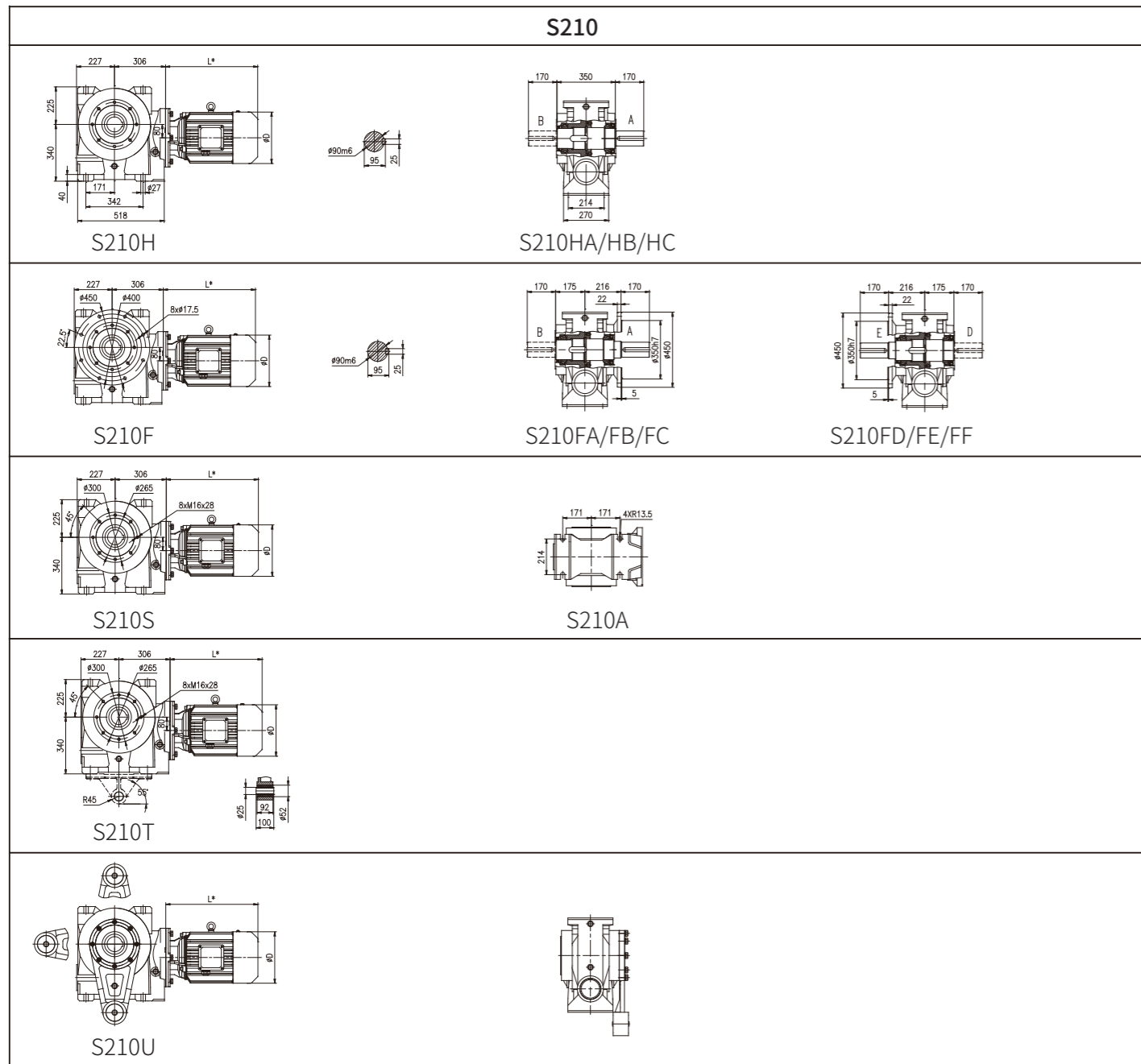

MP motor dimension for S210

MP	P <sub>i</sub> /kW	i <sub>N</sub>	MP							D
			L1	L2	L3	L5	L6	L7		
Fan	1.5	250-400	325	370	380	425	425	480	176	
Driven fan	2.2	160-400	370	410	445	485	485	540	202	
Brake fan	3	100-400	370	410	445	485	485	540	202	
Double brake	4	63-400	434	484	509	559	559	614	220	
Brake + fan	5.5	40-224	439	489	519	564	564	619	259	
Encoder + fan	7.5	28-224	477	527	557	602	602	657	259	
Encoder + Driven fan	11	18-160	533	568	628	658	658	708	314	
Brake + Encoder + Driven fan	15	18-100	563	598	658	688	688	738	314	
	18.5	18-71	604	634	714	739	739	784	356	
	22	18-63	652	682	762	787	787	832	356	
	30	18-35.5	705	710	820	825	825	870	398	

注:渐开线花键空心轴的花键规格DIN5480: m3×z27×α30×D85×9H

Note: Involute spline size DIN5480: m3×z27×α30×D85×9H

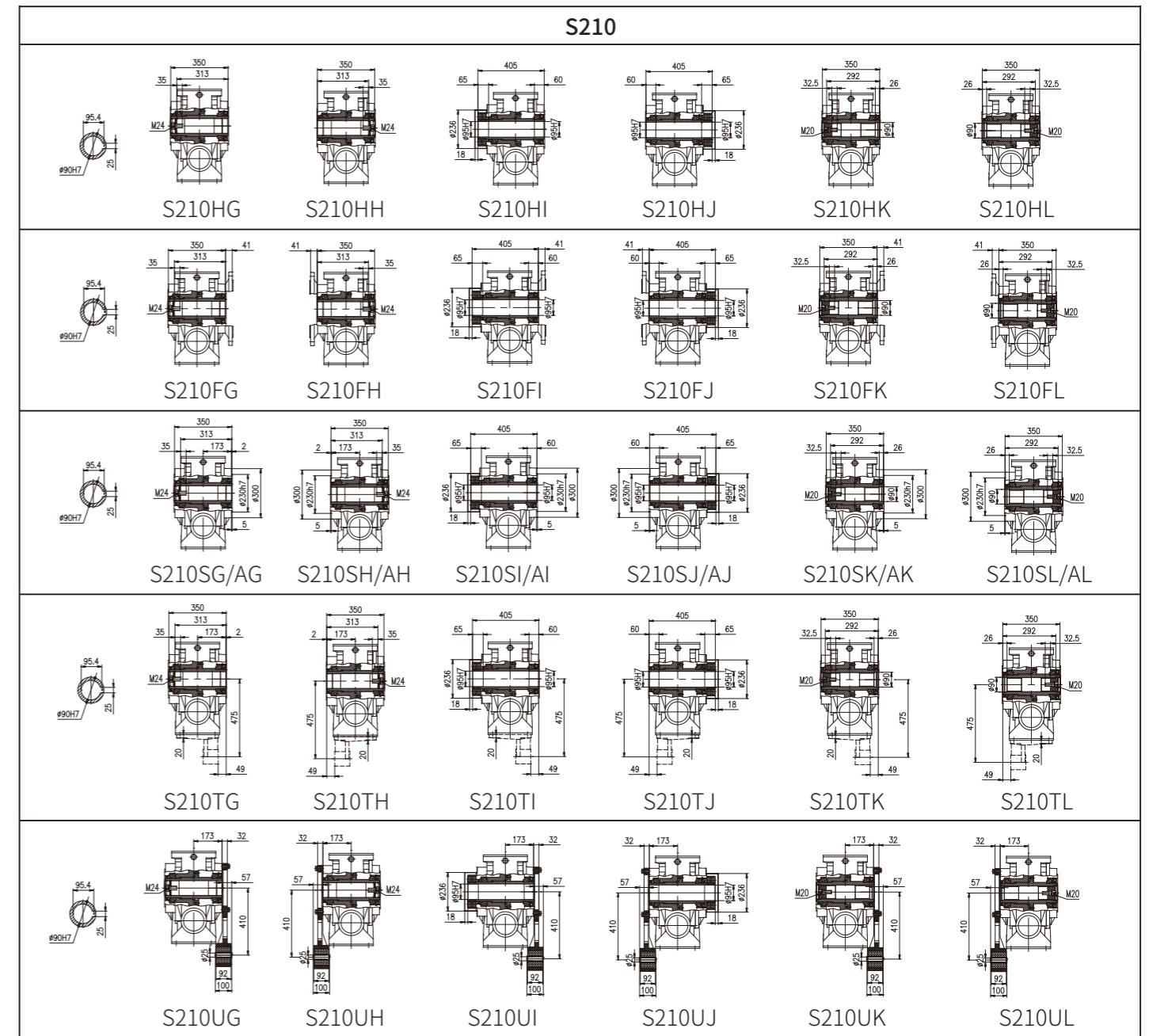

S210/C.07

MP motor dimension for S210/C.07

MP	P <sub>i</sub> /kW	i <sub>N</sub>	MP							D
			L1	L2	L3	L5	L6	L7		
S210/C207	0.12	250-20000	207	262	242	297	/	/	124	
S210/C307	0.18	250-12500	207	262	242	297	/	/	124	
	0.25	250-10000	224	269	264	314	314	354	139	
	0.37	250-6300	224	269	264	314	314	354	139	
	0.55	250-4500	300	345	360	405	405	455	162	
	0.75	250-3550	300	345	360	405	405	455	162	
	1.1	250-2500	323	368	378	423	423	478	176	
	1.5	250-1600	348	393	403	448	448	503	176	
	2.2	250-1120	395	435	470	510	510	565	202	
	3	250-800	395	435	470	510	510	565	202	
	4	250-630	459	509	534	584	584	639	220	
	5.5	250-450	459	509	539	584	584	639	259	

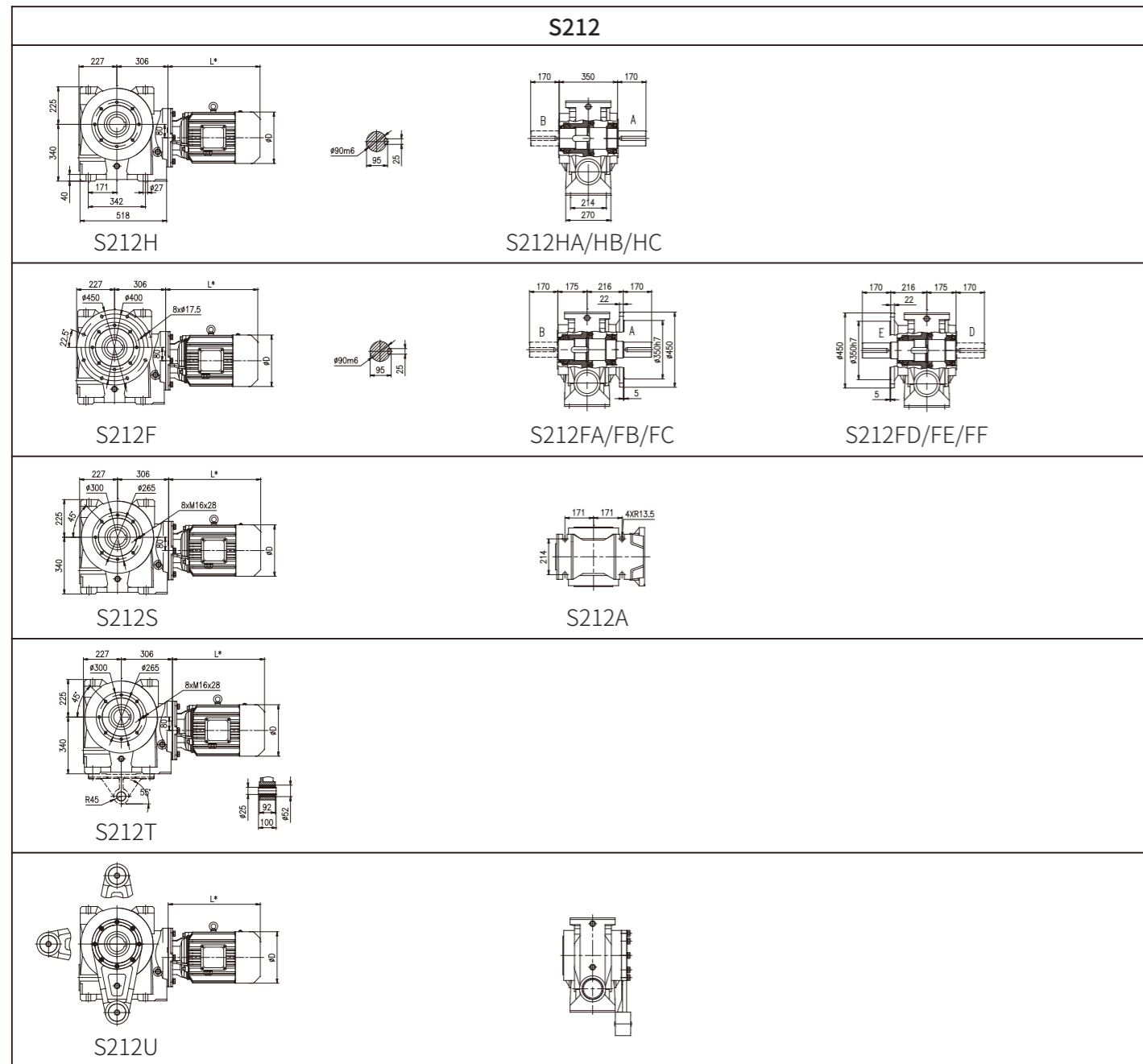

注:渐开线花键空心轴的花键规格DIN5480: m3×z30×α30×D95×9H      Note: Involute spline size DIN5480: m3×z30×α30×D95×9H

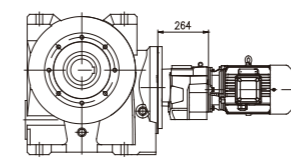
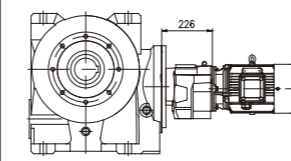
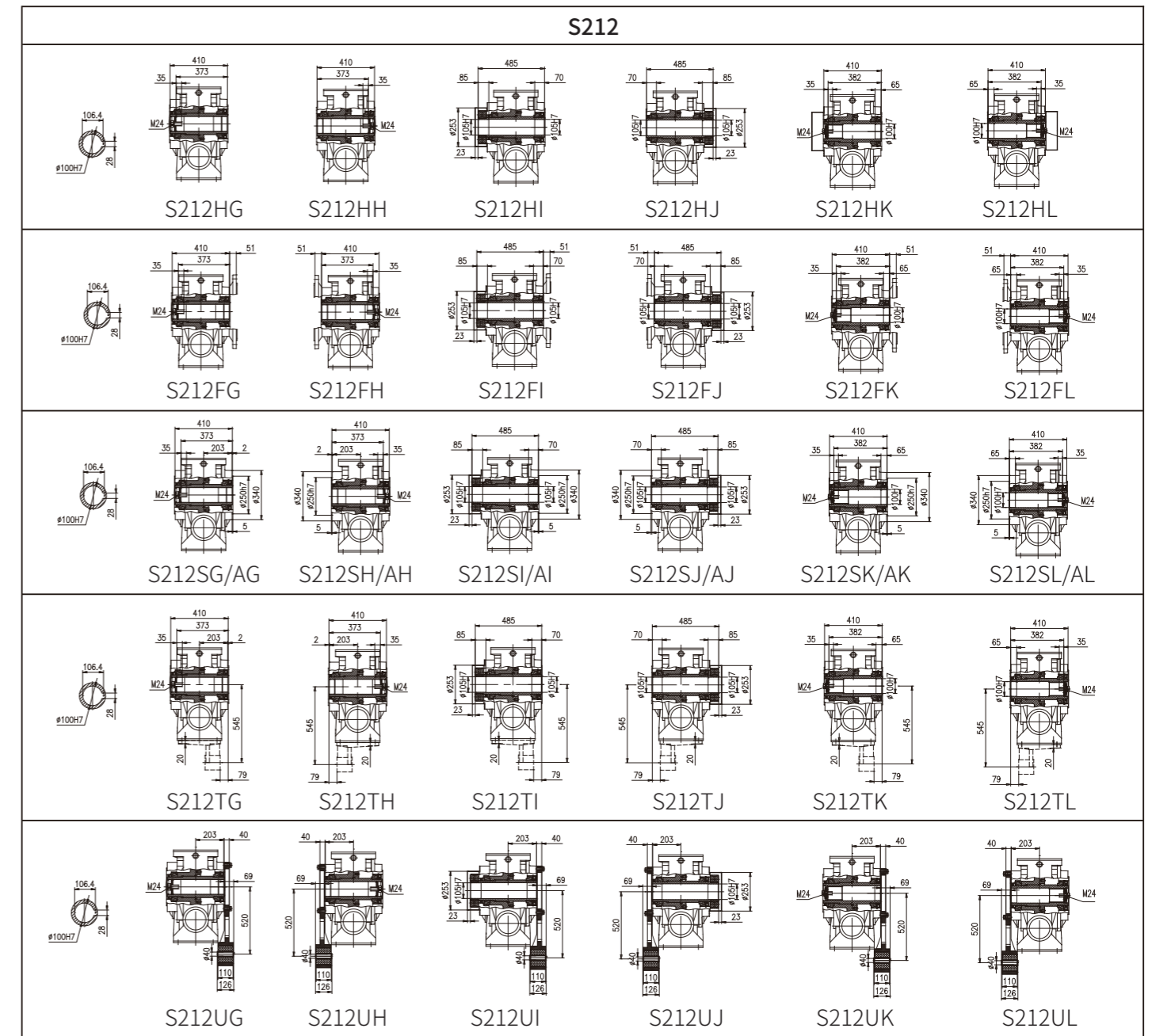

5.2 直连MU电机尺寸

5.2 Dimensions for Directly-connected Motor MU

**S203~S212+MU**

Size	P <sub>1</sub> /kW	i <sub>N</sub>	L1	L2	L3	L5	L6	L7	D
S203	0.12	7.1-180	206	261	241	296	/	/	124
	0.18	7.1-180	206	261	241	296	/	/	124
	0.25	7.1-100	228	268	263	323	323	358	139
	0.37	7.1-63	299	344	359	409	409	454	159
	0.55	7.1-35.5	299	344	359	409	409	454	159
	0.75	7.1-25	322	367	377	427	427	477	176
S204	0.12	7.1-224	206	261	241	296	/	/	124
	0.18	7.1-224	206	261	241	296	/	/	124
	0.25	7.1-224	228	268	263	323	323	358	139
	0.37	7.1-140	299	344	359	409	409	454	159
	0.55	7.1-90	299	344	359	409	409	454	159
	0.75	7.1-63	322	367	377	427	427	477	176
	1.1	7.1-35.5	322	367	377	427	427	477	176
1.5	7.1-20	393	433	468	508	508	563	199	
S205	0.12	8-224	207	262	242	297	/	/	124
	0.18	8-224	207	262	242	297	/	/	124
	0.25	8-224	229	269	264	324	324	359	139
	0.37	8-224	300	345	360	410	410	455	159
	0.55	8-180	300	345	360	410	410	455	159
	0.75	8-125	323	368	378	428	428	478	176
	1.1	8-80	323	368	378	428	428	478	176
	1.5	8-40	394	434	469	509	509	564	199
	2.2	8-25	394	434	469	509	509	564	199
	S206	0.12	280-315	207	262	242	297	/	/
0.18		180-315	207	262	242	297	/	/	124
0.25		125-315	229	269	264	324	324	359	139
0.37		80-315	300	345	360	410	410	455	159
0.55		50-280	300	345	360	410	410	455	159
0.75		28-224	323	368	378	428	428	478	176
1.1		18-140	323	368	378	428	428	478	176
1.5		10-100	394	434	469	509	509	564	199
2.2		7.1-71	394	434	469	509	509	564	199
3		7.1-40	459	509	534	584	584	639	220
4	7.1-25	470	520	550	595	595	650	259	
S207	0.12	355	199	254	234	289	/	/	124
	0.18	355	199	254	234	289	/	/	124
	0.25	315-355	221	261	256	316	316	351	139
	0.37	224-355	292	337	352	402	402	447	159
	0.55	140-355	292	337	352	402	402	447	159
	0.75	80-355	315	360	370	420	420	470	176
	1.1	50-250	315	360	370	420	420	470	176
	1.5	35.5-250	387	427	462	502	502	557	199
	2.2	22.4-200	387	427	462	502	502	557	199
	3	11.2-125	451	501	526	576	576	631	220
	4	8-80	459	509	539	584	584	639	259
	5.5	8-40	497	547	577	622	622	677	259
	7.5	8-35.5	551	586	646	681	681	736	314

**S203~S212+MU**

Size	P <sub>1</sub> /kW	i <sub>N</sub>	L1	L2	L3	L5	L6	L7	D
S208	0.55	250-500	283	328	343	393	393	438	159
	0.75	180-500	306	351	361	411	411	461	176
	1.1	100-315	306	351	361	411	411	461	176
	1.5	50-315	378	418	453	493	493	548	199
	2.2	31.5-315	378	418	453	493	493	548	199
	3	25-250	442	492	517	567	567	622	220
	4	12.5-180	451	501	531	576	576	631	259
	5.5	10-100	489	539	569	614	614	669	259
	7.5	10-50	550	585	645	680	680	735	314
	11	10-31.5	580	615	675	710	710	765	314
S209	0.75	315-500	303	348	358	408	408	458	176
	1.1	224-315	303	348	358	408	408	458	176
	1.5	160-315	374	414	449	489	489	544	199
	2.2	90-315	374	414	449	489	489	544	199
	3	63-315	438	488	513	563	563	618	220
	4	40-315	450	500	530	575	575	630	259
	5.5	20-160	488	538	568	613	613	668	259
	7.5	18-160	544	579	639	674	674	729	314
	11	18-90	574	609	669	704	704	761	314
	15	18-63	615	645	725	750	750	805	356
	18.5	18-40	663	693	773	798	798	853	356
	22	18-31.5	705	710	820	825	825	880	398
	S210	1.5	250-400	370	410	445	485	485	540
2.2		160-400	370	410	445	485	485	540	199
3		100-400	434	484	509	559	559	614	220
4		63-400	439	489	519	564	564	619	259
5.5		40-224	477	527	557	602	602	657	259
7.5		28-224	533	568	628	663	663	718	314
11		18-160	563	598	658	693	693	750	314
15		18-100	604	634	714	739	739	794	356
18.5		18-71	652	682	762	787	787	842	356
22		18-63	705	710	820	825	825	880	398
30		18-35.5	746	776	861	891	891	946	446
2.2		280-450	370	410	445	485	485	540	199
3		200-450	423	473	498	548	548	603	220
4	140-450	429	479	509	554	554	609	259	
S212	5.5	100-250	467	517	547	592	592	647	259
	7.5	63-250	517	552	612	647	647	702	314
	11	35.5-250	547	582	642	677	677	734	314
	15	20-200	588	618	698	723	723	778	356
	18.5	18-160	636	666	746	771	771	826	356
	22	18-140	684	689	799	804	804	859	398
	30	18-80	725	755	840	870	870	925	446
	37	18-63	725	755	840	870	870	925	446
	45	18-45	841	856	981	991	991	1046	485
	55	18-35.5	886	916	1026	1061	1061	1116	547

**S/C+MU**

Size	P <sub>1</sub> /kW	i <sub>N</sub>	L1	L2	L3	L5	L6	L7	D
S203/C. 01	0.12	200-355	206	261	241	296	/	/	124
	0.18	200-250	206	261	241	296	/	/	124
S204/C. 01	0.12	200-630	206	261	241	296	/	/	124
	0.18	200-400	206	261	241	296	/	/	124
S205/C. 03	0.25	200-280	228	268	263	323	323	358	139
	0.12	200-1120	206	261	241	296	/	/	124
	0.18	200-710	206	261	241	296	/	/	124
S206/C. 03	0.25	200-500	228	268	263	323	323	358	139
	0.37	200-315	299	344	359	409	409	454	139
	0.12	200-1800	206	261	241	296	/	/	124
S207/C. 03	0.18	200-1250	206	261	241	296	/	/	124
	0.25	200-900	228	268	263	323	323	358	139
	0.37	200-630	299	344	359	409	409	454	139
	0.55	200-400	299	344	359	409	409	454	162
	0.75	200-280	322	367	377	427	427	477	162
S208/C. 05	0.12	200-4500	206	261	241	296	/	/	124
	0.18	200-3150	206	261	241	296	/	/	124
	0.25	200-2240	228	268	263	323	323	358	139
	0.37	200-1600	299	344	359	409	409	454	139
	0.55	200-1120	299	344	359	409	409	454	162
	0.75	200-800	322	367	377	427	427	477	162
	1.1	200-500	322	367	377	427	427	477	176
	1.5	200-355	393	433	468	508	508	563	176
S209/C. 05	2.2	200-250	393	433	468	508	508	563	202
	0.12	200-8000	207	262	242	297	/	/	124
	0.18	200-5000	207	262	242	297	/	/	124
	0.25	200-3550	229	269	264	324	324	359	139
	0.37	200-2500	300	345	360	410	410	455	139
	0.55	200-1600	300	345	360	410	410	455	162
	0.75	200-1250	323	368	378	428	428	478	162
	1.1	200-800	323	368	378	428	428	478	176
	1.5	200-560	394	434	469	509	509	564	176
	2.2	200-450	394	434	469	509	509	564	202
S210/C. 07	3	200-280	459	509	534	584	584	639	202
	0.12	250-20000	199	254	234	289	/	/	124
	0.18	250-12500	199	254	234	289	/	/	124
	0.25	250-10000	221	261	256	316	316	351	139
	0.37	250-6300	292	337	352	402	402	447	139
	0.55	250-4500	292	337	352	402	402	447	162
	0.75	250-3550	315	360	370	420	420	470	162
	1.1	250-2500	315	360	370	420	420	470	176
	1.5	250-1600	387	427	462	502	502	557	176
	2.2	250-1120	387	427	462	502	502	557	202
S212/C. 08	3	250-800	451	501	526	576	576	631	202
	4	250-630	459	509	539	584	584	639	220
	5.5	250-450	497	547	577	622	622	677	259
	0.12	250-28000	199	254	234	289	/	/	124
	0.18	250-25000	199	254	234	289	/	/	124
	0.25	250-16000	221	261	256	316	316	351	139
	0.37	250-11200	292	337	352	402	402	447	139
	0.55	250-8000	292	337	352	402	402	447	162
	0.75	250-5600	315	360	370	420	420	470	162
	1.1	250-4000	315	360	370	420	420	470	176
S212/C. 07	1.5	250-2800	387	427	462	502	502	557	176
	2.2	250-2000	378	418	453	493	493	548	202
	3	250-1400	442	492	517	567	567	622	202
	4	250-1120	451	501	531	576	576	631	220
	5.5	250-800	489	539	569	614	614	669	259
	7.5	250-560	550	585	645	680	680	735	259
	11	250-400	580	615	675	710	710	765	314

**S/C+MU**

Size	P <sub>1</sub> /kW	i <sub>N</sub>	L1	L2	L3	L5	L6	L7	D
S203/C. 01	0.12	250-14000	207	262	242	297	/	/	124
	0.18	250-9000	207	262	242	297	/	/	124
S209/C. 05	0.25	250-6300	229	269	264	324	324	359	139
	0.37	250-5000	300	345	360	410	410	455	139
	0.55	250-3150	300	345	360	410	410	455	162
	0.75	250-2500	323	368	378	428	428	478	162
	1.1	250-1400	323	368	378	428	428	478	176
	1.5	250-1000	394	434	469	509	509	564	176
	2.2	250-710	394	434	469	509	509	564	202
	3	250-500	459	509	534	584	584	639	202
	4	250-400	470	520	550	595	595	650	220
	S210/C. 07	0.12	250-20000	199	254	234	289	/	/
0.18		250-12500	199	254	234	289	/	/	124
0.25		250-10000	221	261	256	316	316	351	139
0.37		250-6300	292	337	352	402	402	447	139
0.55		250-4500	292	337	352	402	402	447	162
0.75		250-3550	315	360	370	420	420	470	162
1.1		250-2500	315	360	370	420	420	470	176
1.5		250-1600	387	427	462	502	502	557	176
2.2		250-1120	387	427	462	502	502	557	202
3		250-800	451	501	526	576	576	631	202
S212/C. 08	4	250-630	459	509	539	584	584	639	220
	5.5	250-450	497	547	577	622	622	677	259
	0.12	250-28000	199	254	234	289	/	/	124
	0.18	250-25000	199	254	234	289	/	/	124
	0.25	250-16000	221	261	256	316	316	351	139
	0.37	250-11200	292	337	352	402	402	447	139
	0.55	250-8000	292	337	352	402	402	447	162
	0.75	250-5600	315	360	370	420	420	470	162
	1.1	250-4000	315	360	370	420	420	470	176
	S212/C. 07	1.5	250-2800	387	427	462	502	502	557
2.2		250-2000	378	418	453	493	493	548	202
3		250-1400	442	492	517	567	567	622	202
4		250-1120	451	501	531	576	576	631	220
5.5		250-800	489	539	569	614	614	669	259
7.5		250-560	550	585	645	680	680	735	259
11		250-400	580	615	675	710	710	765	314

5.3 直连MA电机尺寸

5.3 Dimensions for Directly-connected Motor MA

S203~S212+MA

Size	P <sub>I</sub> /kW	i <sub>N</sub>	L1	L2	L3	L5	L6	L7	D
S203	0.12	7.1-180	206	261	241	296	/	/	124
	0.18	7.1-180	206	261	241	296	/	/	124
	0.25	7.1-100	223	273	263	318	318	358	139
	0.37	7.1-63	223	273	263	318	318	358	139
	0.55	7.1-35.5	299	344	359	404	404	449	162
	0.75	7.1-25	299	344	359	404	404	449	162
S204	0.12	7.1-224	206	261	241	296	/	/	124
	0.18	7.1-224	206	261	241	296	/	/	124
	0.25	7.1-224	223	273	263	318	318	358	139
	0.37	7.1-140	223	273	263	318	318	358	139
	0.55	7.1-90	299	344	359	404	404	449	162
	0.75	7.1-63	299	344	359	404	404	449	162
S205	1.1	7.1-35.5	347	392	402	452	452	497	176
	1.5	7.1-20	347	392	402	452	452	497	176
	0.12	8-224	207	262	242	297	/	/	124
	0.18	8-224	207	262	242	297	/	/	124
	0.25	8-224	224	274	264	319	319	359	139
	0.37	8-224	224	274	264	319	319	359	139
	0.55	8-180	300	345	360	405	405	450	162
	0.75	8-125	300	345	360	405	405	450	162
	1.1	8-80	348	393	403	453	453	498	176
	1.5	8-40	348	393	403	453	453	498	176
S206	2.2	8-25	395	450	470	530	530	575	202
	0.18	180-315	207	262	242	297	/	/	124
	0.25	125-315	224	274	264	319	319	359	139
	0.37	80-315	224	274	264	319	319	359	139
	0.55	50-280	300	345	360	405	405	450	162
	0.75	28-224	300	345	360	405	405	450	162
	1.1	18-140	348	393	403	453	453	498	176
	1.5	10-100	348	393	403	453	453	498	176
	2.2	7.1-71	395	450	470	530	530	575	202
	3	7.1-40	395	450	470	530	530	575	202
S207	4	7.1-25	459	519	534	599	599	639	220
	0.37	224-355	216	266	256	311	311	351	139
	0.55	140-355	292	337	352	397	397	442	162
	0.75	80-355	292	337	352	397	397	442	162
	1.1	50-250	340	385	395	445	445	490	176
	1.5	35.5-250	340	385	395	445	445	490	176
	2.2	22.4-200	387	442	462	522	522	567	202
	3	11.2-125	387	442	462	522	522	567	202
	4	8-80	451	511	526	591	591	631	220
	5.5	8-40	497	562	577	647	647	677	259
7.5	8-35.5	497	562	577	647	647	677	259	

S203~S212+MA

Size	P <sub>I</sub> /kW	i <sub>N</sub>	L1	L2	L3	L5	L6	L7	D
S208	0.55	250-500	283	328	343	388	388	433	162
	0.75	180-500	283	328	343	388	388	433	162
	1.1	100-315	331	376	386	436	436	481	176
	1.5	50-315	331	376	386	436	436	481	176
	2.2	31.5-315	378	433	453	513	513	558	202
	3	25-250	378	433	453	513	513	558	202
	4	12.5-180	442	502	517	582	582	622	220
	5.5	10-100	489	554	569	639	639	669	259
	7.5	10-50	489	554	569	639	639	669	259
	11	10-31.5	550	600	645	700	700	735	314
S209	15	10-25	580	630	675	730	730	765	314
	0.75	315-500	280	325	340	385	385	430	162
	1.1	224-315	328	373	383	433	433	478	176
	1.5	160-315	328	373	383	433	433	478	176
	2.2	90-315	374	429	449	509	509	554	202
	3	63-315	374	429	449	509	509	554	202
	4	40-315	438	498	513	578	578	618	220
	5.5	20-160	488	553	568	638	638	668	259
	7.5	18-160	488	553	568	638	638	668	259
	11	18-90	544	594	639	694	694	729	314
S210	15	18-63	574	624	669	724	724	759	314
	18.5	18-40	615	660	725	770	770	810	356
	22	18-31.5	663	708	773	818	818	858	356
	1.5	250-400	325	370	380	430	430	475	176
	2.2	160-400	370	425	445	505	505	550	202
	3	100-400	370	425	445	505	505	550	202
	4	63-400	434	494	509	574	574	614	220
	5.5	40-224	477	542	557	627	627	657	259
	7.5	28-224	477	542	557	627	627	657	259
	11	18-160	533	583	628	683	683	718	314
S212	15	18-100	563	613	658	713	713	748	314
	18.5	18-71	604	649	714	759	759	799	356
	22	18-63	652	697	762	807	807	847	356
	30	18-35.5	705	725	820	845	845	890	398
	2.2	280-450	359	414	434	494	494	539	202
	3	200-450	359	414	434	494	494	539	202
	4	140-450	423	483	498	563	563	603	220
	5.5	100-250	467	532	547	617	617	647	259
	7.5	63-250	467	532	547	617	617	647	259
	11	35.5-250	517	567	612	667	667	702	314
S212	15	20-200	547	597	642	697	697	732	314
	18.5	18-160	588	633	698	743	743	783	356
	22	18-140	636	681	746	791	791	831	356
	30	18-80	684	704	799	824	824	869	398
	37	18-63	725	760	840	880	880	920	446
	45	18-45	725	760	840	880	880	920	446
	55	18-35.5	841	866	981	1021	1021	1041	485

**S/C+MA**

Size	P <sub>1</sub> /kW	i <sub>N</sub>	L1	L2	L3	L5	L6	L7	D
S203/C. 01	0.12	200-355	206	/	/	/	/	/	124
	0.18	200-250	206	/	/	/	/	/	124
S204/C. 01	0.12	200-630	206	/	/	/	/	/	124
	0.18	200-400	206	/	/	/	/	/	124
S205/C. 03	0.25	200-280	/	/	/	/	/	/	139
	0.12	200-1120	206	261	241	296	/	/	124
	0.18	200-710	206	261	241	296	/	/	124
	0.25	200-500	223	268	263	318	318	358	139
S206/C. 03	0.37	200-315	223	268	263	318	318	358	139
	0.12	200-1800	206	261	241	296	/	/	124
	0.18	200-1250	206	261	241	296	/	/	124
	0.25	200-900	223	268	263	318	318	358	139
	0.37	200-630	223	268	263	318	318	358	139
S207/C. 03	0.55	200-400	299	344	359	404	404	449	162
	0.12	200-4500	206	261	241	296	/	/	124
	0.18	200-3150	206	261	241	296	/	/	124
	0.25	200-2240	223	273	263	318	318	358	139
	0.37	200-1600	223	273	263	318	318	358	139
	0.55	200-1120	299	344	359	404	404	449	162
	0.75	200-800	299	344	359	404	404	449	162
	1.1	200-500	347	392	402	452	452	497	176
	1.5	200-355	347	392	402	452	452	497	176
2.2	200-250	394	449	469	529	529	574	202	
S208/C. 05	0.12	200-8000	207	262	242	297	/	/	124
	0.18	200-5000	207	262	242	297	/	/	124
	0.25	200-3550	224	274	264	319	319	359	139
	0.37	200-2500	224	274	264	319	319	359	139
	0.55	200-1600	300	345	360	405	405	450	162
	0.75	200-1250	300	345	360	405	405	450	162
	1.1	200-800	348	393	403	453	453	498	176
	1.5	200-560	348	393	403	453	453	498	176
	2.2	200-450	395	450	470	530	530	575	202
	3	200-280	395	450	470	530	530	575	202

**S/C+MA**

Size	P <sub>1</sub> /kW	i <sub>N</sub>	L1	L2	L3	L5	L6	L7	D
S209/C. 05	0.12	250-14000	207	262	242	297	/	/	124
	0.18	250-9000	207	262	242	297	/	/	124
	0.25	250-6300	224	274	264	319	319	359	139
	0.37	250-5000	224	274	264	319	319	359	139
	0.55	250-3150	300	345	360	405	405	450	162
	0.75	250-2500	300	345	360	405	405	450	162
	1.1	250-1400	348	393	403	453	453	498	176
	1.5	250-1000	348	393	403	453	453	498	176
	2.2	250-710	395	450	470	530	530	575	202
	3	250-500	395	450	470	530	530	575	202
S210/C. 07	4	250-400	459	519	534	599	599	639	220
	0.12	250-20000	207	262	242	297	/	/	124
	0.18	250-12500	207	262	242	297	/	/	124
	0.25	250-10000	224	274	264	329	329	364	139
	0.37	250-6300	224	274	264	329	329	364	139
	0.55	250-4500	300	345	355	410	410	450	162
	0.75	250-3550	300	345	355	410	410	450	162
	1.1	250-2500	348	393	403	458	458	498	176
	1.5	250-1600	348	393	403	458	458	498	176
	2.2	250-1120	395	450	470	530	530	575	202
S212/C. 08	3	250-800	395	450	470	530	530	575	202
	4	250-630	459	519	534	599	599	639	220
	5.5	250-450	497	562	577	647	647	677	259
	0.12	250-28000	199	254	234	289	/	/	124
	0.18	250-25000	199	254	234	289	/	/	124
	0.25	250-16000	216	266	256	321	321	356	139
	0.37	250-11200	216	266	256	321	321	356	139
	0.55	250-8000	292	337	347	402	402	442	162
	0.75	250-5600	292	337	347	402	402	442	162
	1.1	250-4000	340	385	395	450	450	490	176
S212/C. 07	1.5	250-2800	340	385	395	450	450	490	176
	2.2	250-2000	387	442	462	522	522	567	202
	3	250-1400	387	442	462	522	522	567	202
	4	250-1120	451	511	526	591	591	631	220
	5.5	250-800	489	554	569	639	639	669	259
	7.5	250-560	489	554	569	639	639	669	259
	11	250-400	550	600	645	700	700	925	314

6 输入法兰和输入轴

6.1 S系列AP输入法兰  
外形尺寸图表

6 Input Flange and Input Shaft

6.1 S series dimensions of AP  
input flange

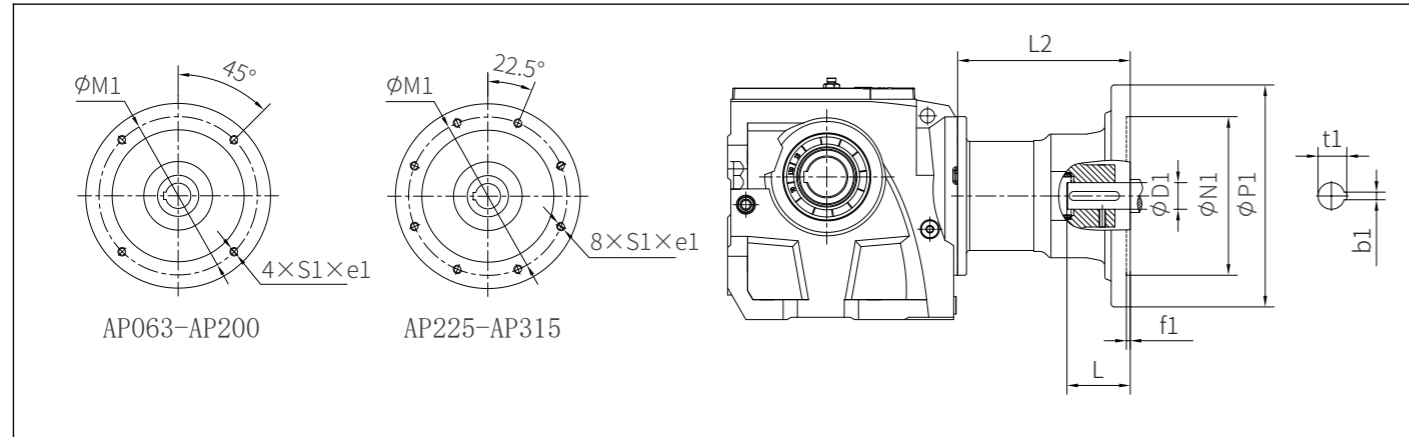

Size	Flange	iN	e1	D1	N1	M1	P1	f1	b1	t1	L	S1	L2	Weight (kg)
S203	AP063	7.1-180	14	11H7	95H7	115	140	4	4	12.8	23	M8	59	4.8
	AP071	7.1-100	14	14H7	110H7	130	160	4	5	16.3	30	M8	59	4.8
	AP080	7.1-35.5	18	19H7	130H7	165	200	4	6	21.8	40	M10	74	7.6
S204	AP063	7.1-224	14	11H7	95H7	115	140	4	4	12.8	23	M8	59	4.8
	AP071	7.1-224	14	14H7	110H7	130	160	4	5	16.3	30	M8	59	4.8
	AP080	7.1-90	18	19H7	130H7	165	200	4	6	21.8	40	M10	74	7.6
S205	AP063	8-224	14	11H7	95H7	115	140	4	4	12.8	23	M8	61	5.1
	AP071	8-224	14	14H7	110H7	130	160	4	5	16.3	30	M8	61	5.1
	AP080	8-180	18	19H7	130H7	165	200	4	6	21.8	40	M10	76	8.6
	AP090	8-80	18	24H7	130H7	165	200	4	8	27.3	50	M10	81	9.2
	AP100	8-25	28	28H7	180H7	215	250	5	8	31.3	60	M12	191	14.1
S206	AP063	7.1-315	14	11H7	95H7	115	140	4	4	12.8	23	M8	61	5.1
	AP071	7.1-315	14	14H7	110H7	130	160	4	5	16.3	30	M8	61	5.1
	AP080	7.1-280	18	19H7	130H7	165	200	4	6	21.8	40	M10	76	8.6
	AP090	7.1-140	18	24H7	130H7	165	200	4	8	27.3	50	M10	81	9.2
	AP100	7.1-71	28	28H7	180H7	215	250	5	8	31.3	60	M12	191	14.1
	AP112	7.1-25	28	28H7	180H7	215	250	5	8	31.3	60	M12	191	14.1
S207	AP071	8-355	14	14H7	110H7	130	160	4	5	16.3	30	M8	53	6.7
	AP080	8-355	18	19H7	130H7	165	200	4	6	21.8	40	M10	68	10.3
	AP090	8-250	18	24H7	130H7	165	200	4	8	27.3	50	M10	73	11.1
	AP100	8-200	28	28H7	180H7	215	250	5	8	31.3	60	M12	181	15.5
	AP112	8-80	28	28H7	180H7	215	250	5	8	31.3	60	M12	181	15.5
	AP132	8-40	28	38H7	230H7	265	300	5	10	41.3	80	M12	210	22.3

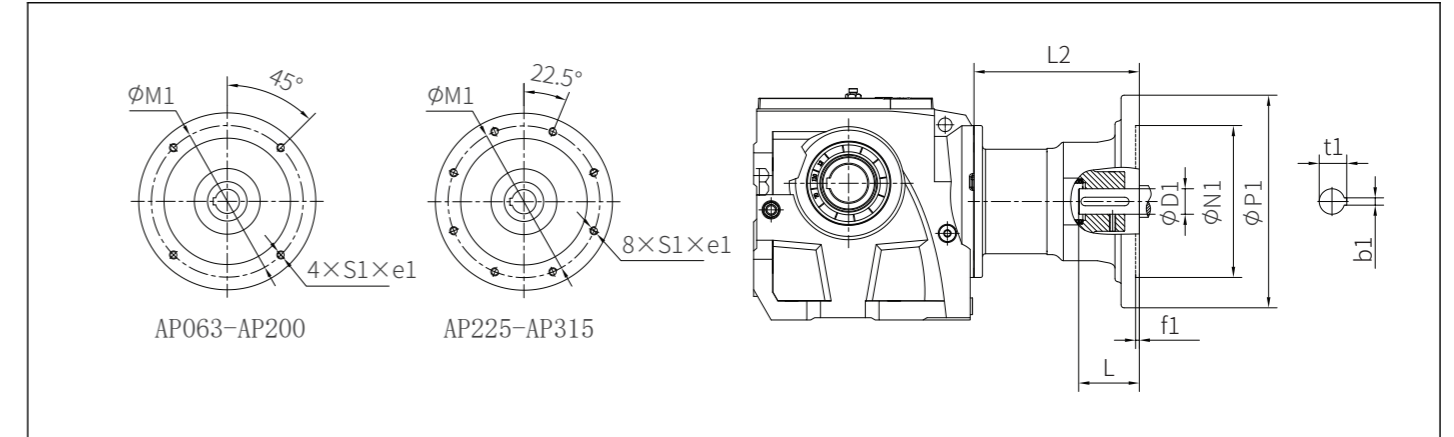

Size	Flange	iN	e1	D1	N1	M1	P1	f1	b1	t1	L	S1	L2	Weight (kg)
S208	AP080	180-500	18	19H7	130H7	165	200	4	6	21.8	40	M10	65	10.4
	AP090	10-315	18	24H7	130H7	165	200	4	8	27.3	50	M10	66	12.1
	AP100	10-315	28	28H7	180H7	215	250	5	8	31.3	60	M12	171	18.2
	AP112	10-180	28	28H7	180H7	215	250	5	8	31.3	60	M12	171	18.2
	AP132	10-100	28	38H7	230H7	265	300	5	10	41.3	80	M12	203	24.9
	AP160	10-31.5	40	42H7	250H7	300	350	6	12	45.3	110	M16	272	46.4
S209	AP090	18-315	18	24H7	130H7	165	200	4	8	27.3	50	M10	61	14.7
	AP100	18-315	28	28H7	180H7	215	250	5	8	31.3	60	M12	172	21.5
	AP112	18-315	28	28H7	180H7	215	250	5	8	31.3	60	M12	172	21.5
	AP132	18-160	28	38H7	230H7	265	300	5	10	41.3	80	M12	202	28.3
	AP160	18-90	40	42H7	250H7	300	350	6	12	45.3	110	M16	270	49.9
	AP180	18-40	40	48H7	250H7	300	350	6	14	51.8	110	M16	270	49.9
S210	AP100	18-400	28	28H7	180H7	215	250	5	8	31.3	60	M12	162	25.6
	AP112	18-400	28	28H7	180H7	215	250	5	8	31.3	60	M12	162	25.6
	AP132	18-224	28	38H7	230H7	265	300	5	10	41.3	80	M12	189	33.7
	AP160	18-160	40	42H7	250H7	300	350	6	12	45.3	110	M16	257	52.3
	AP180	18-71	40	48H7	250H7	300	350	6	14	51.8	110	M16	257	52.3
	AP200	18-35.5	40	55H7	300H7	350	400	6	16	59.3	110	M16	327	77.4
	AP132	18-250	28	38H7	230H7	265	300	5	10	41.3	80	M12	175	46.4
S212	AP160	18-250	40	42H7	250H7	300	350	6	12	45.3	110	M16	243	66.9
	AP180	18-160	40	48H7	250H7	300	350	6	14	51.8	110	M16	243	66.9
	AP200	18-80	40	55H7	300H7	350	400	6	16	59.3	110	M16	316	89.8
	AP225	18-63	30	60H7	350H7	400	450	6	18	64.4	140	M16	343	97.5
	AP250	18-35.5	32	65H7	450H7	500	550	7	18	69.4	140	M16	361	131.3

6.2 S系列AS输入法兰  
外形尺寸图表

6.2 S series dimensions  
of AS input flange

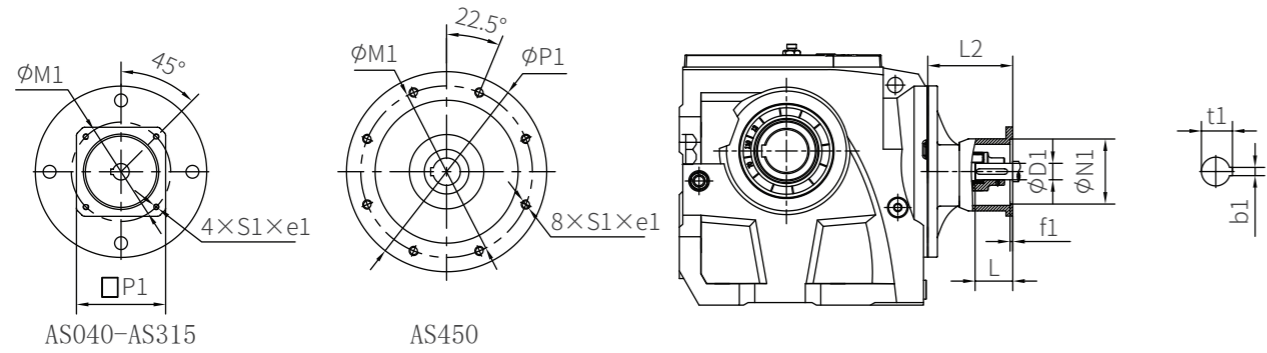

Size	Flange	iN	e1	D1	N1	M1	P1	f1	b1	t1	L	S1	L2	Weight (kg)
S203	AS040	7.1-180	4	8H7	30H7	46	78	4	2	9	25	M4	65	2.5
	AS055	7.1-180	4	9H7	40H7	63	78	4	3	10.4	25	M5	65	2.5
	AS060	7.1-180	10	14H7	50H7	70	60	4	5	16.3	30	M5	114	3.2
	AS070	7.1-180	10	14H7	60H7	75	70	4	5	16.3	30	M5	114	3.3
	AS080	7.1-180	10	19H7	70H7	90	80	4	6	21.8	35	M6	120	3.4
	AS090	7.1-180	10	19H7	80H7	100	90	4	6	21.8	40	M6	125	3.6
S204	AS040	7.1-224	4	8H7	30H7	46	78	4	2	9	25	M4	65	2.5
	AS055	7.1-224	4	9H7	40H7	63	78	4	3	10.4	25	M5	65	2.5
	AS060	7.1-224	10	14H7	50H7	70	60	4	5	16.3	30	M5	114	3.2
	AS070	7.1-224	10	14H7	60H7	75	70	4	5	16.3	30	M5	114	3.3
	AS080	7.1-224	10	19H7	70H7	90	80	4	6	21.8	35	M6	120	3.4
	AS090	7.1-224	10	19H7	80H7	100	90	4	6	21.8	40	M6	125	3.6
	AS100	7.1-125	14	19H7	95H7	115	100	4	6	21.8	45	M8	122	3.9
	AS125	7.1-125	15	24H7	110H7	130	130	5	8	27	50	M8	133	4.9
S205	AS060	8-224	10	14H7	50H7	70	60	4	5	16.3	30	M5	116	4.1
	AS070	8-224	10	14H7	60H7	75	70	4	5	16.3	30	M5	116	4.2
	AS080	8-224	10	19H7	70H7	90	80	4	6	21.8	35	M6	122	4.3
	AS090	8-224	10	19H7	80H7	100	90	4	6	21.8	40	M6	127	4.5
	AS100	8-180	14	19H7	95H7	115	100	4	6	21.8	45	M8	124	4.8
	AS125	8-180	15	24H7	110H7	130	130	5	8	27	50	M8	135	5.8
	AS140	8-180	15	24H7	110H7	145	130	5.5	8	27	55	M8	135	5.7
	AS160	8-180	15	32H7	130H7	165	155	5	10	35.3	60	M10	190	9.9
S206	AS060	7.1-315	10	14H7	50H7	70	60	4	5	16.3	30	M5	116	4.1
	AS070	7.1-315	10	14H7	60H7	75	70	4	5	16.3	30	M5	116	4.2
	AS080	7.1-315	10	19H7	70H7	90	80	4	6	21.8	35	M6	122	4.3
	AS090	7.1-315	10	19H7	80H7	100	90	4	6	21.8	40	M6	127	4.5
	AS100	7.1-200	14	19H7	95H7	115	100	4	6	21.8	45	M8	124	4.8
	AS125	7.1-200	15	24H7	110H7	130	130	5	8	27	50	M8	135	5.8
	AS140	7.1-200	15	24H7	110H7	145	130	5.5	8	27	55	M8	135	5.7
	AS160	7.1-200	15	32H7	130H7	165	155	5	10	35.3	60	M10	190	9.9

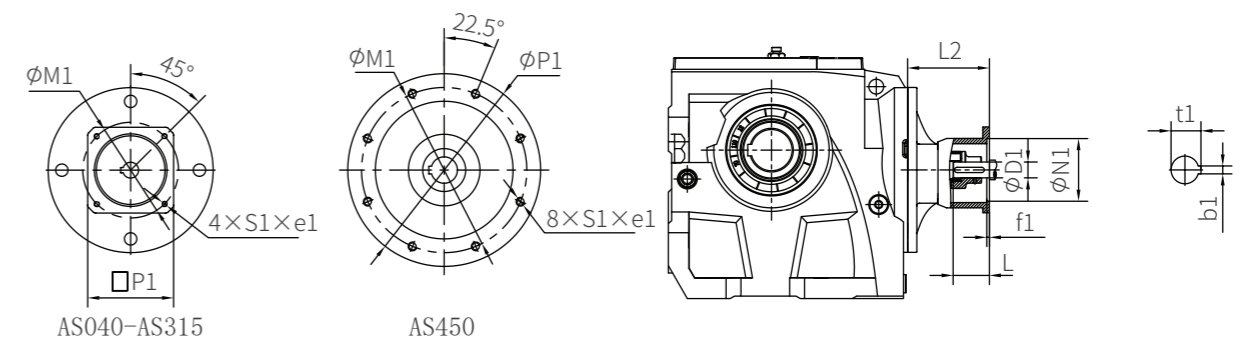

Size	Flange	iN	e1	D1	N1	M1	P1	f1	b1	t1	L	S1	L2	Weight (kg)
S207	AS060	8-355	10	14H7	50H7	70	60	4	5	16.3	30	M5	108	5.6
	AS070	8-355	10	14H7	60H7	75	70	4	5	16.3	30	M5	108	5.7
	AS080	8-355	10	19H7	70H7	90	80	4	6	21.8	35	M6	114	5.8
	AS090	8-355	10	19H7	80H7	100	90	4	6	21.8	40	M6	119	6
	AS100	8-250	14	19H7	95H7	115	100	4	6	21.8	45	M8	116	6.3
	AS125	8-250	15	24H7	110H7	130	130	5	8	27	50	M8	127	7.3
	AS140	8-250	15	24H7	110H7	145	130	5.5	8	27	55	M8	127	7.2
	AS160	8-250	15	32H7	130H7	165	155	5	10	35.3	60	M10	180	11.3
	AS180	8-40	16	35H7	114.3H7	200	180	7	10	38.3	80	M12	210	16.7
	AS190	8-40	18	38H7	180H7	215	190	5	10	41.3	80	M12	210	17.1
S208	AS240	8-40	28	38H7	230H7	265	240	5	10	41.3	80	M12	210	22.3
	AS070	180-500	10	14H7	60H7	75	70	4	5	16.3	30	M5	105	8
	AS080	180-500	10	19H7	70H7	90	80	4	6	21.8	35	M6	111	8.1
	AS090	180-500	10	19H7	80H7	100	90	4	6	21.8	40	M6	116	8.3
	AS100	10-315	14	19H7	95H7	115	100	4	6	21.8	45	M8	113	8.6
	AS125	10-315	15	24H7	110H7	130	130	5	8	27	50	M8	124	9.6
	AS140	10-315	15	24H7	110H7	145	130	5.5	8	27	55	M8	124	9.5
	AS160	10-315	15	32H7	130H7	165	155	5	10	35.3	60	M10	170	14
	AS180	10-160	16	35H7	114.3H7	200	180	7	10	38.3	80	M12	203	19.3
	AS190	10-160	18	38H7	180H7	215	190	5	10	41.3	80	M12	203	19.7
S209	AS240	10-160	28	38H7	230H7	265	240	5	10	41.3	80	M12	203	24.9
	AS260	10-160	40	48H7	250H7	300	260	6	14	51.8	110	M16	272	46.4
	AS160	18-315	15	32H7	130H7	165	155	5	10	35.3	60	M10	171	17.3
	AS180	18-160	16	35H7	114.3H7	200	180	7	10	38.3	80	M12	202	22.7
	AS190	18-160	18	38H7	180H7	215	190	5	10	41.3	80	M12	202	23.1
S210	AS240	18-160	28	38H7	230H7	265	240	5	10	41.3	80	M12	202	28.3
	AS260	18-160	40	48H7	250H7	300	260	6	14	51.8	110	M16	271	49.9
	AS160	18-400	15	32H7	130H7	165	155	5	10	35.3	60	M10	161	21.4
	AS180	18-224	16	35H7	114.3H7	200	180	7	10	38.3	80	M12	189	28.1
	AS190	18-224	18	38H7	180H7	215	190	5	10	41.3	80	M12	189	28.5
S212	AS240	18-224	28	38H7	230H7	265	240	5	10	41.3	80	M12	189	33.7
	AS260	18-224	40	48H7	250H7	300	260	6	14	51.8	110	M16	258	52.3
	AS315	18-40	40	55H7	300H7	350	315	6	16	59.3	110	M16	327	77.4
	AS180	18-250	16	35H7	114.3H7	200	180	7	10	38.3	80	M12	175	40.8
	AS190	18-250	18	38H7	180H7	215	190	5	10	41.3	80	M12	175	41.2

6.3 S系列AN输入法兰  
外形尺寸图表 (mm)

6.3 S Series Dimensions  
of AN Input Flange(mm)

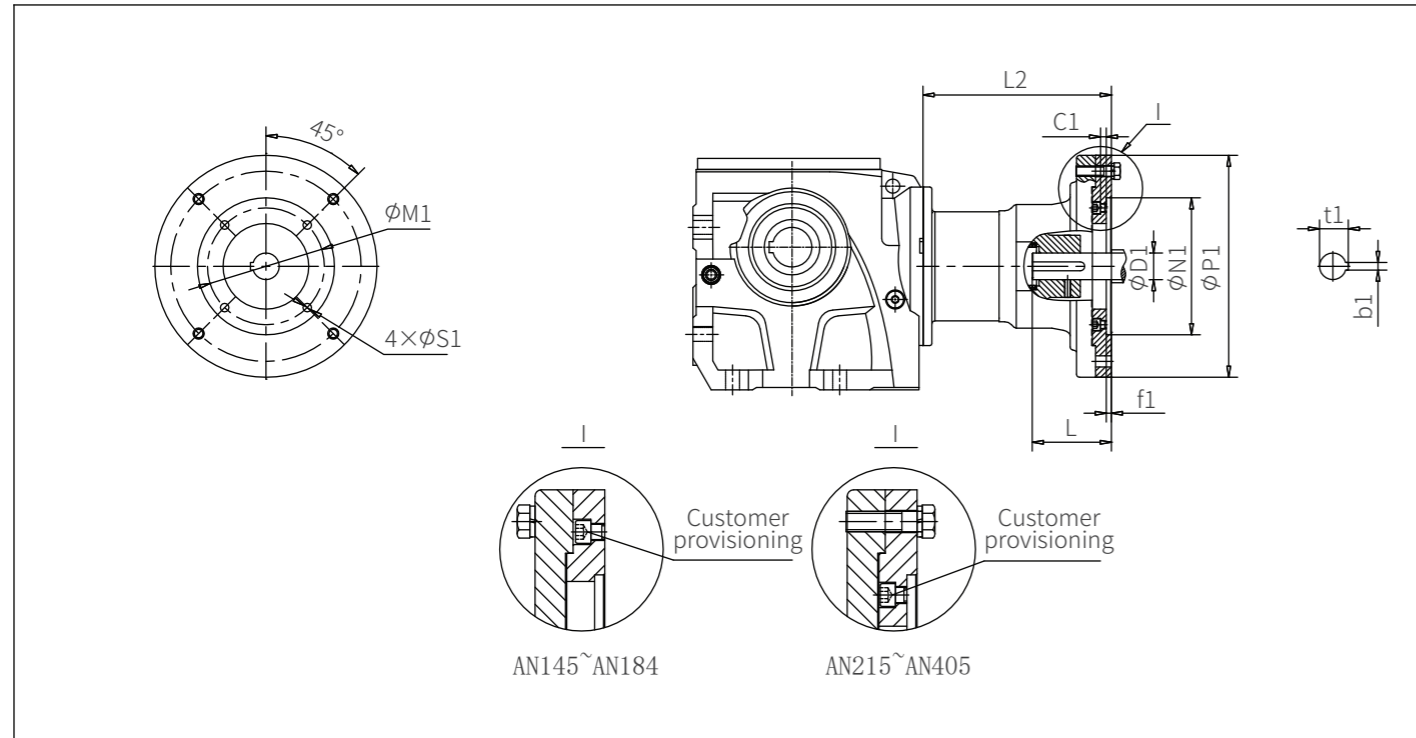

Size	Flange	NEMA Motor Frame	Power (HP)	IEC Standard Power (KW)	c1	D1	N1	M1	P1	f1	b1	t1	L	S1	L2
S203	AN145	143TC	1/1.5	0.75/1.1	6	22.225H7	114.3H7	149.2	200	5	4.76	24.7	58.04	11	92
		145TC	2	1.5											
S204	AN145	143TC	1/1.5	0.75/1.1	6	22.225H7	114.3H7	149.2	200	5	4.76	24.7	58.04	11	92
		145TC	2	1.5											
S205	AN145	143TC	1/1.5	0.75/1.1	6	22.225H7	114.3H7	149.2	200	5	4.76	24.7	58.04	11	94
		145TC	2	1.5											
	AN184	182TC	3	2.2	8	28.575H7	215.9H7	184.2	250	8	6.35	31.7	73.03	13.5	220.5
		184TC	5	4											
S206	AN145	143TC	1/1.5	0.75/1.1	6	22.225H7	114.3H7	149.2	200	5	4.76	24.7	58.04	11	94
		145TC	2	1.5											
	AN184	182TC	3	2.2	8	28.575H7	215.9H7	184.2	250	8	6.35	31.7	73.03	13.5	220.5
		184TC	5	4											
S207	AN145	143TC	1/1.5	0.75/1.1	6	22.225H7	114.3H7	149.2	200	5	4.76	24.7	58.04	11	86
		145TC	2	1.5											
	AN184	182TC	3	2.2	8	28.575H7	215.9H7	184.2	250	8	6.35	31.7	73.03	13.5	210.5
		184TC	5	4											
	AN215	213TC	7.5	5.5	9	34.925H7	215.9H7	184.15	300	8	7.94	38.7	85.73	13.5	235
		215TC	10	7.5											
S208	AN145	143TC	1/1.5	0.75/1.1	6	22.225H7	114.3H7	149.2	200	5	4.76	24.7	58.04	11	83
		145TC	2	1.5											
	AN184	182TC	3	2.2	8	28.575H7	215.9H7	184.2	250	8	6.35	31.7	73.03	13.5	200.5
		184TC	5	4											
	AN215	213TC	7.5	5.5	9	34.925H7	215.9H7	184.15	300	8	7.94	38.7	85.73	13.5	228
		215TC	10	7.5											
	AN256	254TC	15	11	9	41.275H7	215.9H7	184.15	350	8	9.53	45.8	101.6	13.5	297
		256TC	20	15											

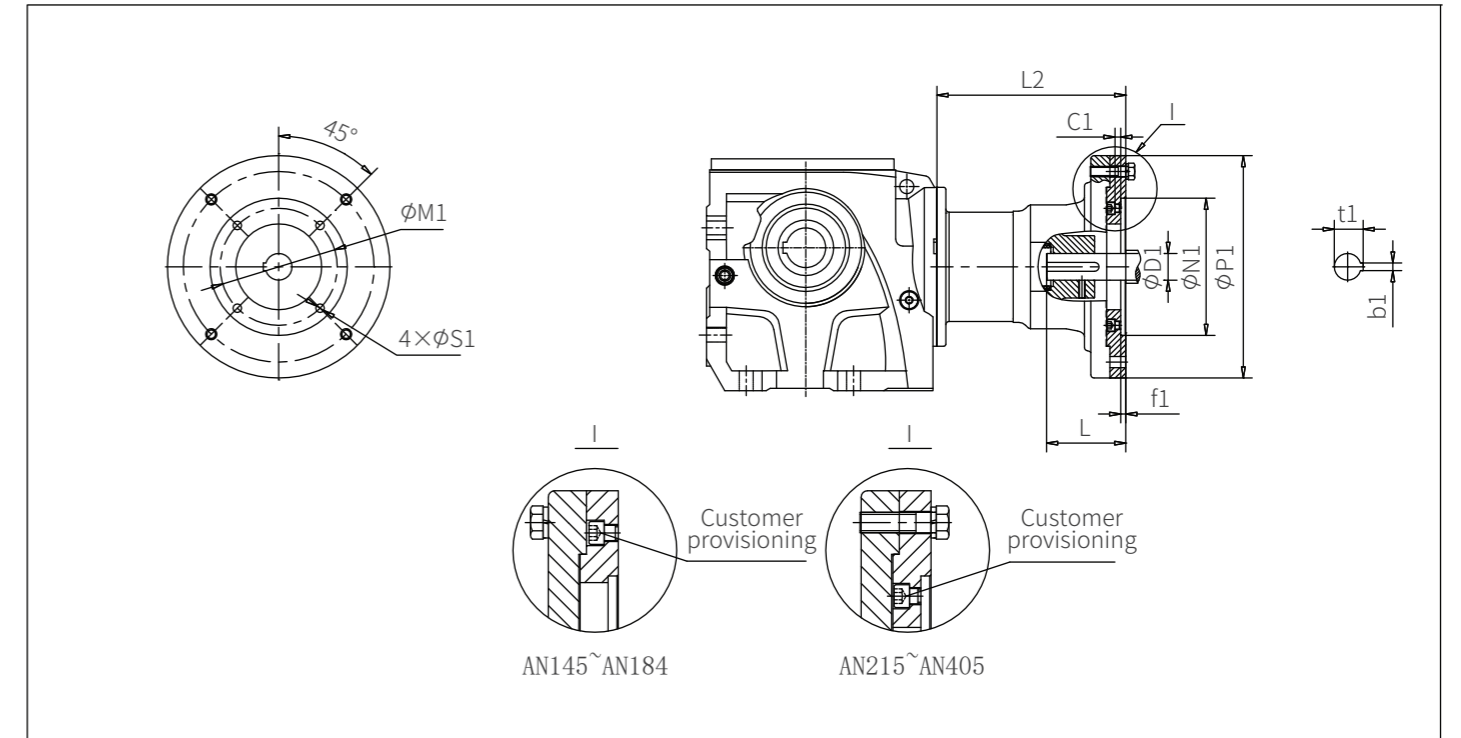

Size	Flange	NEMA Motor Frame	Power (HP)	IEC Standard Power (KW)	c1	D1	N1	M1	P1	f1	b1	t1	L	S1	L2
S209	AN184	182TC	3	2.2	8	28.575H7	215.9H7	184.2	250	8	6.35	31.7	73.03	13.5	201.5
		184TC	5	4											
	AN215	213TC	7.5	5.5	9	34.925H7	215.9H7	184.15	300	8	7.94	38.7	85.73	13.5	227
		215TC	10	7.5											
S210	AN184	182TC	3	2.2	8	28.575H7	215.9H7	184.2	250	8	6.35	31.7	73.03	13.5	191.5
		184TC	5	4											
	AN215	213TC	7.5	5.5	9	34.925H7	215.9H7	184.15	300	8	7.94	38.7	85.73	13.5	214
		215TC	10	7.5											
S212	AN256	254TC	15	11	9	41.275H7	215.9H7	184.15	350	8	9.53	45.8	101.6	13.5	269
		256TC	20	15											
	AN286	284TC	25	18.5	9	47.625H7	266.7H7	228.6	400	8	12.7	53.4	117.48	13.5	341
		286TC	30	22											
S212	AN215	213TC	7.5	5.5	9	34.925H7	215.9H7	184.15	300	8	7.94	38.7	85.73	13.5	200
		215TC	10	7.5											
	AN256	254TC	15	11	9	41.275H7	215.9H7	184.15	350	8	9.53	45.8	101.6	13.5	269
		256TC	20	15											
	AN326	324TC	40	30	9.5	53.975H7	317.5H7	279.4	450	8	12.7	60	133.35	17.5	373
		326TC	50	37											
AN365	364TC	60	45	24.5	60.325H7	317.5H7	279.4	450	8	15.88	67.6	149.23	17.5	388	
	365TC	75	55												
AN405	405TC	100	75	64.5	73.025H7	317.5H7	279.4	450	8	19.05	81.9	184.15	17.5	428	

6.4 S系列AE输入轴  
外形尺寸图表

6.4 S series dimensions  
of AE input shaft

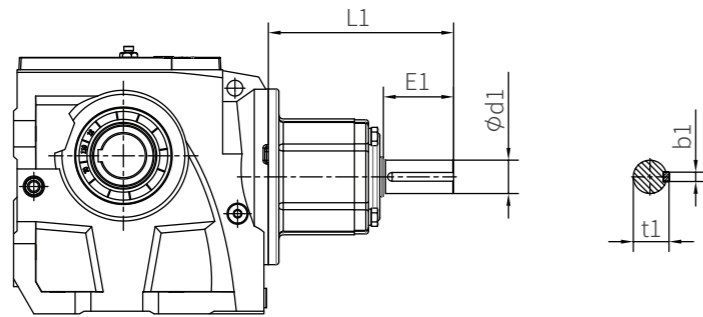

Size	Input Shaft	P <sub>1</sub> (kW)	i <sub>N</sub>	d <sub>1</sub>	E <sub>1</sub>	L <sub>1</sub>	b <sub>1</sub>	t <sub>1</sub>	Weight (kg)
S203	AE2	0.12-0.75	7.1-180	19k6	40	117	6	21.5	2.5
S204	AE2	0.12-0.75	7.1-224	19k6	40	117	6	21.5	2.5
S205	AE2	0.12-0.75	8-224	19k6	40	119	6	21.5	3.4
	AE3	1.1-4	8-80	28k6	60	175	8	31	6.1
S206	AE2	0.12-0.75	7.1-315	19k6	40	119	6	21.5	3.4
	AE3	1.1-4	7.1-140	28k6	60	175	8	31	6.1
S207	AE2	0.12-0.75	7.1-355	19k6	40	111	6	21.5	4.9
	AE3	1.1-4	8-250	28k6	60	165	8	31	7.5
	AE4	5.5-7.5	8-40	38k6	80	211	10	41	10.5
S208	AE2	0.12-0.75	180-500	19k6	40	108	6	21.5	7.2
	AE3	1.1-4	10-315	28k6	60	155	8	31	10.2
	AE4	5.5-11	10-100	38k6	80	204	10	41	13.1
	AE5	15-22	10-25	42k6	110	266	12	45	23.3
S209	AE3	1.1-4	18-315	28k6	60	156	8	31	10.2
	AE4	5.5-11	18-160	38k6	80	203	10	41	13.1
	AE5	15-22	18-63	42k6	110	265	12	45	23.3
S210	AE3	1.1-4	18-400	28k6	60	146	8	31	17.6
	AE4	5.5-11	18-224	38k6	80	190	10	41	21.9
	AE5	15-22	18-100	42k6	110	252	12	45	29.2
	AE6	30-45	18-35.5	48k6	110	309	14	51.5	45.5
S212	AE4	5.5-11	18-250	38k6	80	176	10	41	34.6
	AE5	15-22	18-200	42k6	110	238	12	45	43.8
	AE6	30-45	18-80	48k6	110	298	14	51.5	57.9
	AE7	55-90	18-35.5	55m6	110	297	16	59	64.6

7 外形尺寸图(附表)

7 Dimensions(Supplement)

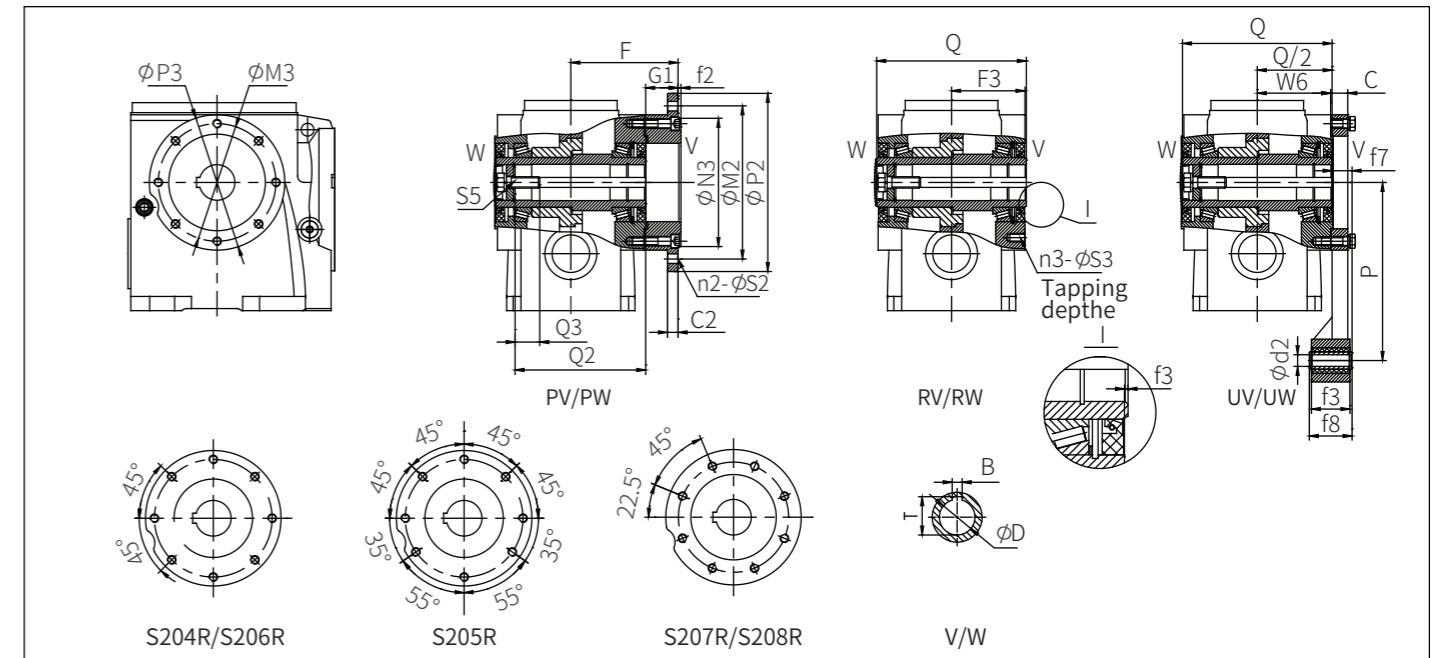

安装形式 Mode	Size	S204					S205					S206					S207					S208																																																																																																																																																																				
		法兰式安装 Flange-mounted	N2	110h7	/	130h7	180h7	250h7	M2	130	/	165	215	300	P2	160	/	200	250	350	G1	25	/	42.5	45.5	52.5	F	85	/	132.5	150.5	172.5	f2	3.5	/	4	4	5	C2	10	/	15	16	18	n2	4	/	4	4	4	S2	9	/	11	13.5	17.5	M3	115	102	130	155	180	P3	132	132	150	190	250	F3	58	73	88	103	118	f3	2	2	2	2	2	n3	8	8	8	8	8	S3	M8	M8	M12	M12	M16	e	17	17	18	21	28	f7	18.5	16.5	17.5	28	23.5	P	130	160	200	250	310	d2	10.4	10.4	10.4	16.4	16.4	f3	31	31	31	54	54	f8	36	36	36	60	60	C	15	16	18	24	24	W6	58	73	88	103	118	D	30H7	30H7	45H7	60H7	70H7	Q	120	150	180	210	240	Q/2	60	75	90	105	120	S5	M10	M12	M16	M16	M20	Q2	105	132	144	183	210	Q3	17	25	30	35	36	B	8	8	14	18	20	T	33.3	33.3	48.8

注:  
1.S2..R.表示轴装式安装,不含外接小法兰;  
2.型号示例:S207PV代表法兰外径φ250、空心轴孔径φ60H7的S207配置。

Note:  
1.S2..R. represents shaft mounted installation, excluding external small flange;  
2.Model example: S207PV represents the configuration of S207 with a flange outer diameter of φ250 and a hollow shaft aperture of φ60H7.

8 马达防雨罩尺寸

8 Motor Rainproof Cover Dimensions

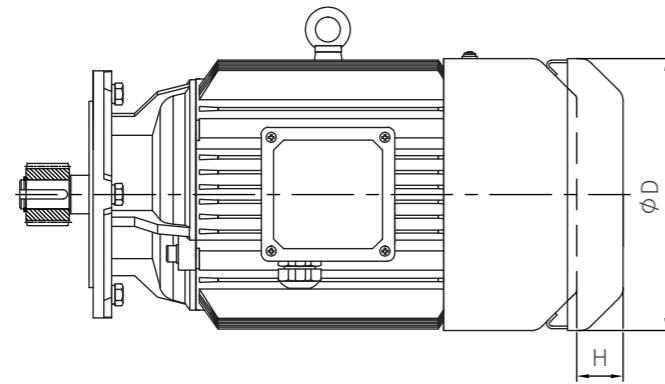

机座 Frame 号 Size	H63	H71	H80	H90	H100	H112	H132	H160	H180	H200	H225	H250	H280
D	124	139	159	176	199	220	259	314	356	398	446	485	547
H	25	30	30	35	40	40	40	60	60	70	70	80	80

9 被驱动轴推荐尺寸

9 Recommended Dimensions for Driven Equipment Shaft

9.1 锁紧盘

9.1 Shrink disk

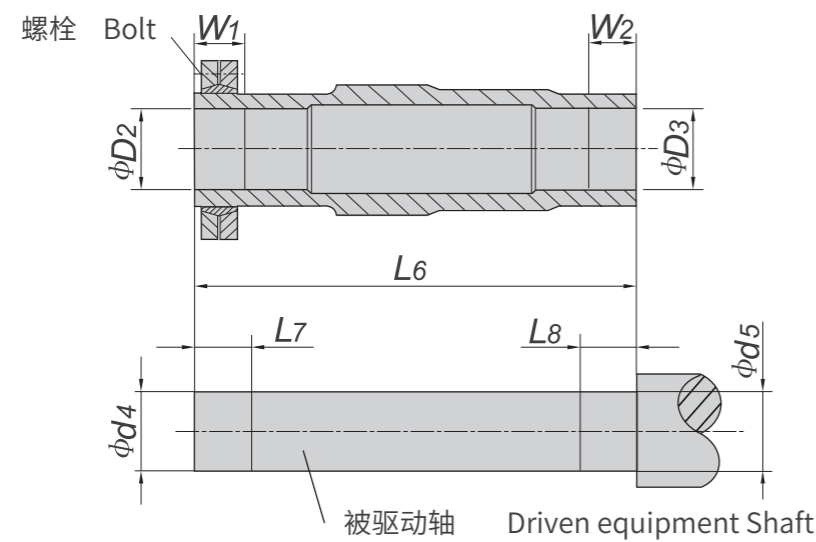

规格 Size	D2	D3	d4	d5	L6	L7	L8	W1	W2	型号 Type	螺栓 Bolt	重量 Weight
S203	25H7	25H7	25h6	25h6	145	40	40	35	35	SP2-36×72	M6	0.6
S204	25H7	25H7	25h6	25h6	145	40	40	35	35	SP2-36×72	M6	0.6
S205	35H7	35H7	35h6	35h6	177	35	25	30	20	SP2-44×80	M6	0.8
S206	40H7	40H7	40h6	40h6	208	43	25	38	20	SP2-50×90	M6	0.8
S207	50H7	50H7	50h6	50h6	241	41	35	36	30	SP2-62×110	M6	1.3
S208	65H7	65H7	65h6	65h6	281	46	45	41	40	SP2-80×145	M8	1.9
S209	75H7	75H7	75h6	75h6	345	60	55	55	50	SP2-90×155	M8	3.3
S210	95H7	95H7	95h6	95h6	405	75	70	65	60	SP2-110×185	M10	5.9
S212	105H7	105H7	105h6	105h6	485	95	80	85	70	SP2-140×230	M12	10

9.2 花键轴

9.2 Involute spline

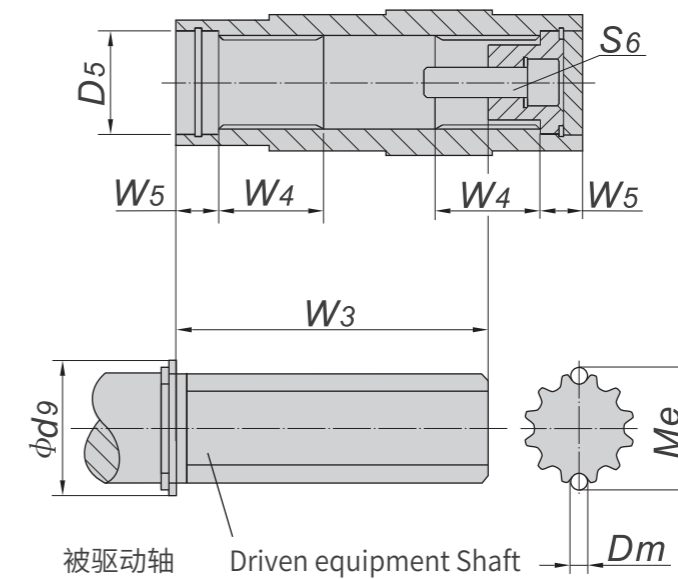

规格 Size	D5	Dm	d9	Me	W3	W4	W5	S6
S203	32	2.75	37	27.99	90	25	18	M10×30
S204	32	2.75	37	27.99	90	25	18	M10×30
S205	37	4	42	38.92	115	32	18	M10×30
S206	42	4	47	38.92	140	42	25	M16×40
S207	55	4	62	54.13	160	52	23	M16×50
S208	72	4	82	68.96	180	62	25	M20×60
S209	72	4	90	74.15	240	72	25	M20×60
S210	90	6	105	91	290	89	26	M20×60
S212	100	6	120	101.05	380	92	28	M24×60

10 轴端中心孔

10 Shaft End Centre Hole

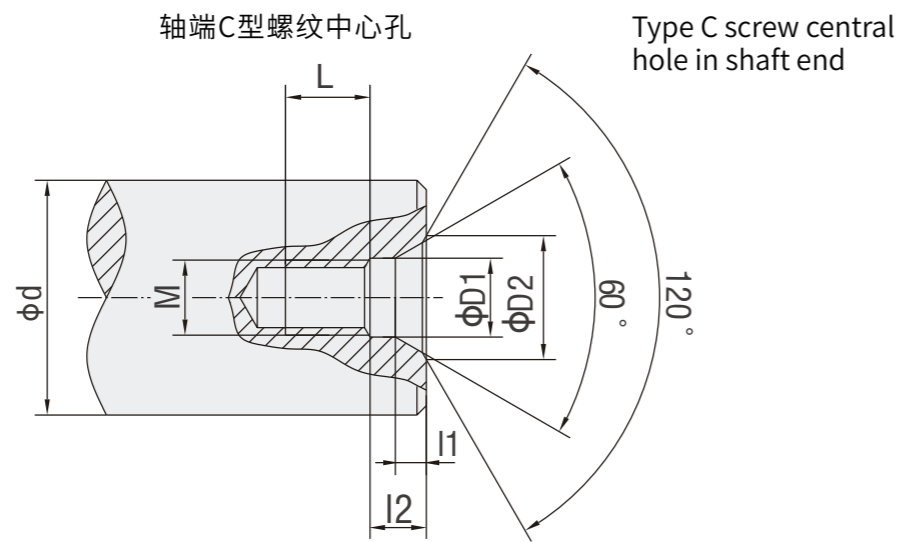

d	M	L	12	11	D1	D2
7 < d ≤ 10	M3	10	2.6	1.8	3.2	5.8
10 < d ≤ 13	M4	10	3.2	2.1	4.3	7.4
13 < d ≤ 16	M5	10	4	2.4	5.3	8.8
16 < d ≤ 21	M6	12	5	2.8	6.4	10.5
21 < d ≤ 24	M8	12	6	3.3	8.4	13.2
24 < d ≤ 30	M10	15	7.5	3.8	10.5	16.3
30 < d ≤ 38	M12	20	9.5	4.4	13	19.8
38 < d ≤ 50	M16	25	12	5.2	17	25.3
50 < d ≤ 85	M20	30	15	6.4	21	31.3
85 < d ≤ 130	M24	35	18	8	25	38
130 < d ≤ 225	M30	45	18	11	31	48

11 平键与键槽的尺寸

11 Dimension of Parallel Key and Keyway

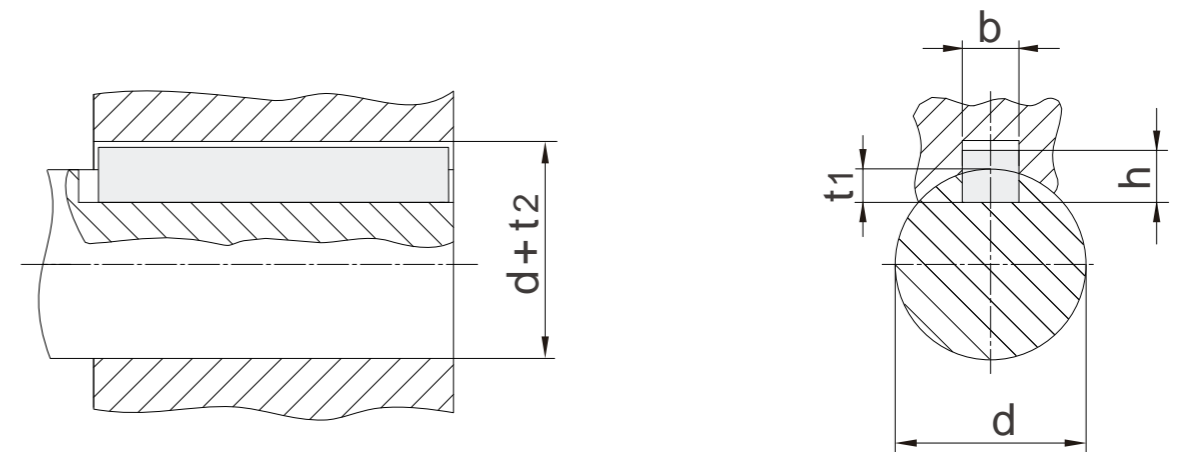

d	b	h	t1	d + t2
8 < d ≤ 10	3	3	1.8	d + 1.4
10 < d ≤ 12	4	4	2.5	d + 1.8
12 < d ≤ 17	5	5	3	d + 2.3
17 < d ≤ 22	6	6	3.5	d + 2.8
22 < d ≤ 30	8	7	4	d + 3.3
30 < d ≤ 38	10	8	5	d + 3.3
38 < d ≤ 44	12	8	5	d + 3.3
44 < d ≤ 50	14	9	5.5	d + 3.8
50 < d ≤ 58	16	10	6	d + 4.3
58 < d ≤ 65	18	11	7	d + 4.4
65 < d ≤ 75	20	12	7.5	d + 4.9
75 < d ≤ 85	22	14	9	d + 5.4
85 < d ≤ 95	25	14	9	d + 5.4
95 < d ≤ 110	28	16	10	d + 6.4
110 < d ≤ 130	32	18	11	d + 7.4
130 < d ≤ 150	36	20	12	d + 8.4
150 < d ≤ 170	40	22	13	d + 9.4
170 < d ≤ 200	45	25	15	d + 10.4
200 < d ≤ 230	50	28	17	d + 11.4
230 < d ≤ 260	56	32	20	d + 12.4

12 逆止器与齿轮  
马达输出旋向对照表

12 Comparison table of  
backstop and motor  
output rotation direction

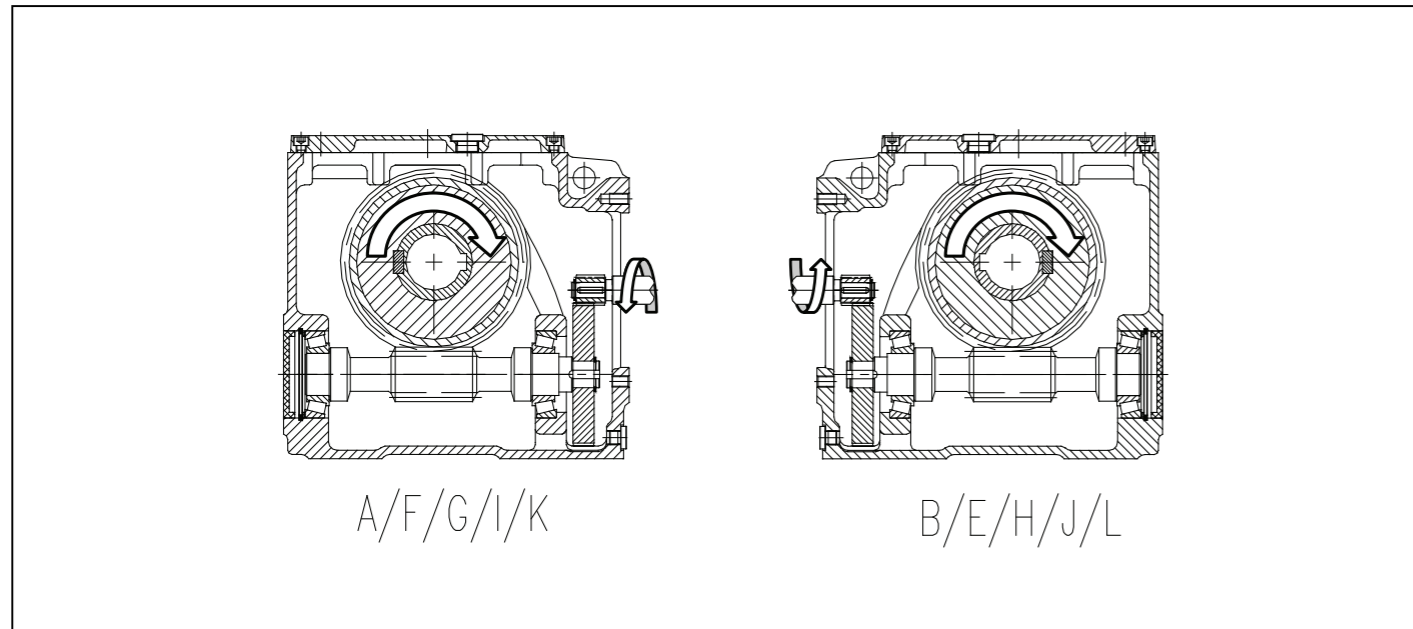

逆止器选项和S  
系列输出形式关系

Relationship of backstop & S  
series output mode

输出形式 Output mode	输出轴旋向 (面向输出 轴端面) Output shaft rotational direction (when facing to it)	逆止器 Backstop
A/D/G/I/K	CW	P
	CCW	Q
B/E/H/J/L	CW	Q
	CCW	P

注意: CW为顺时针, CCW为逆时针  
P为逆止器顺时针, Q为逆止器逆时针

Attention: CW is clockwise while  
CCW is counter-clockwise.  
P is clockwise for the backstop,  
Q is counter-clockwise.

13 润滑油

13.1 S203~S212

13 Oil

13.1 S203~S212

安装方位 Mounting position 型号 Size	D1	D2	D3	D4	D5	D6
S203	0.3	0.5	0.6	0.7	0.5	0.5
S204	0.5	1.1	1.1	1.4	1.2	1.2
S205	0.6	1.4	1.2	1.9	1.7	1.7
S206	1.2	2.6	3.7	3.8	3.2	3.2
S207	2.3	5.0	7.0	7.8	5.9	5.9
S208	4.6	9.7	12.5	14.4	10.9	10.9
S209	8.9	18.0	22.6	28.3	21.6	21.6
S210	12.5	45.6	37.8	45.6	25.4	25.4
S212	22.0	80.4	63.6	80.4	42.8	42.8

13.2 S&C组合型

13.2 S&C combi-type

安装方位 Mounting position 型号 Size	D1	D2	D3	D4	D5	D6
S203&C201	0.3+0.4	0.5+0.4	0.6+0.4	0.7+0.5	0.5+0.4	0.5+0.4
S203&C301	0.3+0.3	0.5+0.3	0.6+0.3	0.7+0.4	0.5+0.3	0.5+0.3
S204&C201	0.5+0.4	1.1+0.4	1.1+0.4	1.4+0.5	1.2+0.4	1.2+0.4
S204&C301	0.5+0.3	1.1+0.3	1.1+0.3	1.4+0.4	1.2+0.3	1.2+0.3
S205&C203	0.6+0.4	1.4+1	1.2+1.1	1.9+1.2	1.7+0.9	1.7+1.1
S205&C303	0.6+0.3	1.4+0.9	1.2+0.9	1.9+1	1.7+0.8	1.7+0.9
S206&C203	1.2+0.4	2.6+1	3.7+1.1	3.8+1.2	3.2+0.9	3.2+1.1
S206&C303	1.2+0.3	2.6+0.9	3.7+0.9	3.8+1	3.2+0.8	3.2+0.9
S207&C203	2.3+0.4	5+1	7+1.1	7.8+1.2	5.9+0.9	5.9+1.1
S207&C303	2.3+0.3	5+0.9	7+0.9	7.8+1	5.9+0.8	5.9+0.9
S208&C205	4.6+1.5	9.7+1.7	12.5+1.8	14.4+1.8	10.9+2.6	10.9+2.5
S208&C305	4.6+1.3	9.7+1.4	12.5+1.5	14.4+1.5	10.9+2.2	10.9+2.1
S209&C205	8.9+1.5	18+1.7	22.6+1.8	28.3+1.8	21.6+2.6	21.6+2.5
S209&C305	8.9+1.3	18+1.4	22.6+1.5	28.3+1.5	21.6+2.2	21.6+2.1
S210&C207	12.5+2	45.6+2.9	37.8+2.8	45.6+3.1	25.4+3.6	25.4+3.5
S210&C307	12.5+1.7	45.6+2.5	37.8+2.4	45.6+2.6	25.4+3.1	25.4+3
S212&C208	22+2.6	80.4+7.1	63.6+7.5	80.4+8.1	42.8+6.6	42.8+7.2
S212&C307	22+1.7	80.4+2.5	63.6+2.4	80.4+2.6	42.8+3.1	42.8+3
S212&C308	22+2.6	80.4+7.1	63.6+7.5	80.4+8.1	42.8+6.6	42.8+7.2

注:S和C组合产品需分别加注润滑油

Attention: Please supply lubricant  
oil for both S part and C part of the  
combination

14 重量表

14 Weight

14.1 齿轮箱及直连马达重量表 (Kg)

14.1 Weight of Gearbox & Directly-connected Motor (kg)

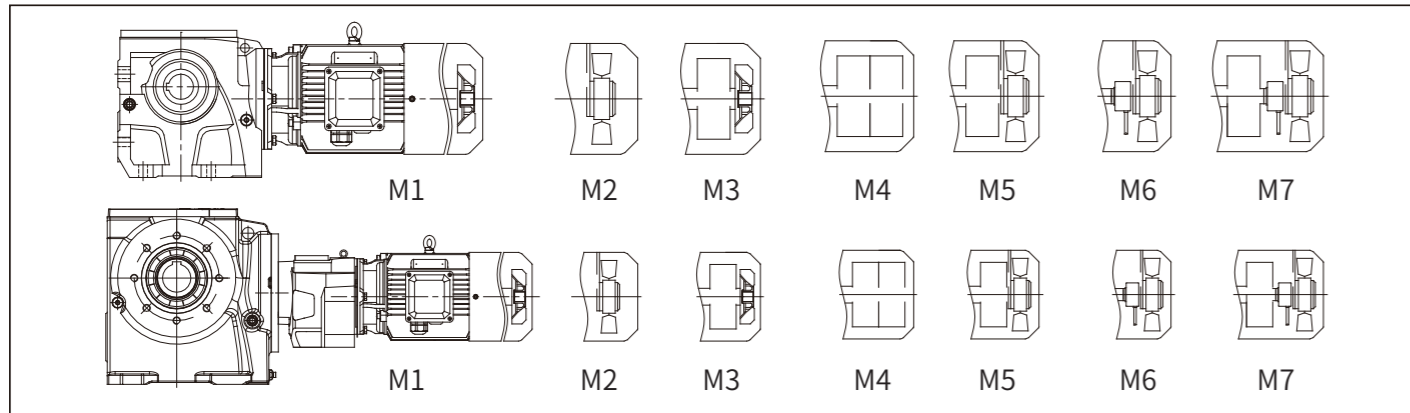

- |                  |                              |
|------------------|------------------------------|
| M1: 自扇冷却         | M1: Self-fan cooling         |
| M2: 强冷风机         | M2: Driven fan               |
| M3: 制动器+自扇冷却     | M3: Brake+Self-fan cooling   |
| M4: 双制动器         | M4: Double brake             |
| M5: 制动器+强冷风机     | M5: Brake+Driven fan         |
| M6: 编码器+强冷风机     | M6: Encoder+Driven fan       |
| M7: 制动器+编码器+强冷风机 | M7: Brake+Encoder+Driven fan |

14.1 齿轮箱重量表 (Kg) 14.1 Weight of Gearbox & Directly-connected Motor (Kg)

规格	S203	S204	S205	S206	S207	S208	S209	S210	S212	
重量	9	13	18	30	53	98	175	250	425	
规格	S203&C201 S203&C301	S204&C201 S204&C301	S205&C203 S205&C303	S206&C203 S206&C303	S207&C203 S207&C303	S208&C205 S208&C305	S209&C205 S209&C305	S210&C207 S210&C307	S212&C208 S212&C308	S212&C307
重量	17	21	27	39	62	118	195	286	491	461

直连马达重量表 (Kg) Weight of Directly-connected Motor (kg)

4极功率 (kW)	MH							MP							MU							MA						
	M1	M2	M3	M4	M5	M6	M7	M1	M2	M3	M5	M6	M7	M1	M2	M3	M5	M6	M7	M1	M2	M3	M5	M6	M7			
0.12	7	8	9	/	9	/	/	7	8	9	9	/	/	7.5	8	9	9.5	/	/	7	8	9	9	/	/			
0.18	7	8	9	/	9	/	/	8	9	10	10	/	/	7.5	8	9	9.5	/	/	8	9	10	10	/	/			
0.25	8	9	10	/	11	10	12	9	10	11	12	11	13	10	11	11	12	11	13	9	10	11	12	11	13			
0.37	9	10	11	/	12	11	13	10	11	12	13	12	14	15	16	19	20	17	21	10	11	12	13	12	14			
0.55	14	15	18	/	19	16	20	15	16	19	20	17	21	16	17	20	21	18	22	15	16	19	20	17	21			
0.75	15	16	19	/	20	17	21	16	17	20	21	18	22	20	21	24	25	22	26	16	17	20	21	18	22			
1.1	18	19	22	/	23	20	24	20	21	24	25	22	26	22	23	26	27	24	28	21	22	25	26	23	27			
1.5	19	20	23	/	24	21	25	22	23	26	27	24	28	31	32	39	40	33	41	23	24	27	28	25	29			
2.2	30	31	38	/	39	32	40	32	33	40	41	34	42	34	35	42	43	36	44	36	37	44	45	38	45			
3	33	34	41	/	42	35	43	36	37	44	45	38	46	55	57	63	64	58	65	36	37	44	45	38	45			
4	52	53	60	/	61	54	62	56	57	64	65	58	66	75	77	87	89	78	90	56	57	64	65	58	66			
5.5	67	69	78	/	80	70	81	77	79	88	90	80	91	78	80	89	91	81	92	77	79	88	90	80	91			
7.5	80	82	91	/	93	83	94	88	90	99	101	91	102	128	130	149	151	131	152	88	90	99	101	91	102			
11	121	123	142	/	143	124	144	129	131	150	151	132	152	160	162	181	183	163	184	129	131	150	151	132	152			
15	139	141	160	/	161	142	162	161	163	182	183	164	184	198	200	230	232	201	234	161	163	182	183	164	184			
18.5	182	184	214	/	215	185	217	200	202	232	233	203	235	218	220	250	252	221	254	200	202	232	233	203	235			
22	204	206	236	/	237	207	239	220	222	252	253	223	255	279	280	329	330	281	332	220	222	252	253	223	255			
30	260	260	310	/	360	308	361	280	280	330	328	281	330	343	345	393	394	346	396	280	280	330	328	281	330			
37	330	332	380	/	381	334	383	345	347	395	396	349	398	365	367	415	416	368	418	345	347	395	396	349	398			
45	345	347	395	/	396	349	398	365	367	415	416	369	418	467	469	572	573	470	575	365	367	415	416	369	418			
55	435	436	540	/	535	436	537	470	471	575	570	471	572	627	629	732	734	630	736	470	471	575	570	470	572			
75	575	577	680	/	678	578	680	630	632	735	733	633	735	650	652	755	757	653	759	630	632	735	733	633	735			
90	645	647	750	/	748	648	750	710	712	815	813	713	815	720	722	825	827	723	829	710	712	815	813	713	815			

14.2 输入法兰及输入轴重量表 (Kg)

14.2 Weight of Input Flange & Input Shaft (kg)

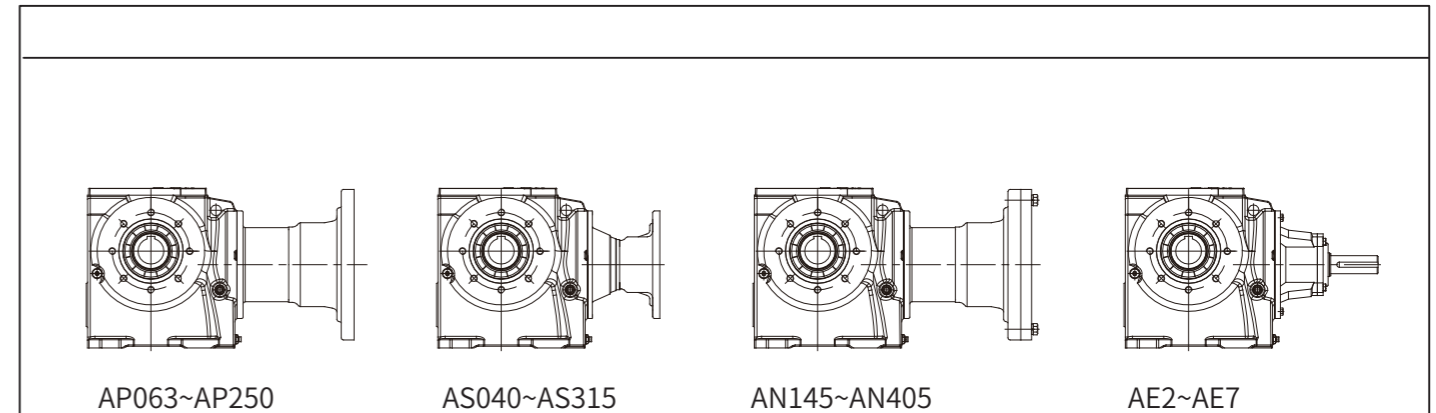

		AP输入法兰重量表 (kg)				Weight of AP Input Flange (kg)			
规格	Size	AP063	AP071	AP080	AP090	AP100	AP112		
重量	Weight	5	5	9	11	18	18		
规格	Size	AP132	AP160	AP180	AP200	AP225	AP250		
重量	Weight	30	70	70	95	107	144		

		AS输入法兰重量表 (kg)				Weight of AS Input Flange (kg)			
规格	Size	AS040	AS055	AS060	AS070	AS080	AS090	AS100	AS125
重量	Weight	3	3	4	5	5	5	6	7
规格	Size	AS140	AS160	AS180	AS190	AS240	AS260	AS315	
重量	Weight	6	13	24	25	30	70	95	

		AN输入法兰重量表 (kg)				Weight of AN Input Flange (kg)			
规格	Size	AN145	AN184	AN215	AN256	AN286	AN326	AN365	AN405
重量	Weight	13	27	43	89	119	140	154	201

		AE输入法兰重量表 (kg)				Weight of AE Input Flange (kg)			
规格	Size	AE2	AE3	AE4	AE5	AE6	AE7		
重量	Weight	4	9	17	46	63	77		

随着技术迭代进步，博能产品样本将会同步更新，请见谅。  
 Along with the technology advancedet.,the product of the manual of Boneng will be changed,please forgive.

控制层 CONTROL

驱动层 DRIVE

马达层 MOTOR

齿轮层 GEAR



**X3010 PLC**  
EtherCAT&Modbus  
24VDC



**X3050 运动控制器**  
Motion Controller  
EtherCAT&Modbus  
24VDC

**C/F/K/S-M**  
\* . . . D  
马达分布式变频驱动器  
Integrated Gearmotor Drive

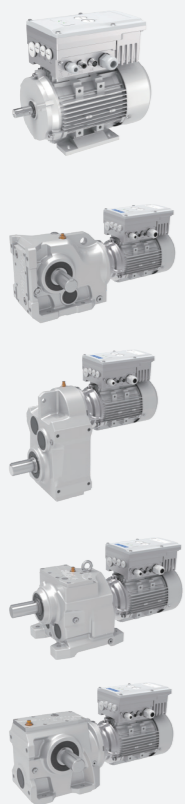

EtherCAT&Modbus  
380~480VAC  
0.25~3kW  
i=4~355

**AM 变频驱动器**  
Variable Frequency Drive



Modbus  
380~480VAC  
0.75~5.5kW

**A1 变频驱动器**  
Variable Frequency Drive

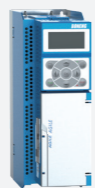

Modbus/CANopen/  
PROFINET  
380~480VAC  
0.75~250kW

**C/F/K/S/R**  
齿轮马达  
Gearmotor



380~480VAC  
0.09~200kW  
i=1.25~500

**MP/MU/MA**  
三相交流异步马达  
Asynchronous Motor



380~480VAC  
0.09~90kW  
960/1450r/min  
1160/1750r/min

**HB/BE/HK**  
齿轮箱  
Gearbox



4.2~15775kW  
i=5.6~450

**P/PK**  
行星齿轮箱  
Planetary Gearbox

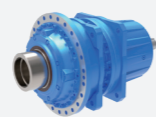

0.4~14000kW  
i=25~4000

**PW**  
卷扬齿轮箱  
Planetary Winch Gearbox

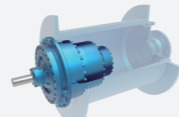

1~1810kW  
i=13~940

**PS**  
回转齿轮箱  
Planetary Slewing Gearbox



1~1626kW  
i=14~947

**J/JB**  
升降机  
Jack



0.35~22.63kW  
i=5~34

**T**  
转向箱  
Spiral Bevel Gearbox

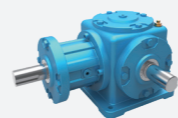

0.08~303kW  
i=1:1~3:1

**MX&AX**  
伺服马达&伺服驱动器  
Permanent Magnet Servo Motor & Servo Drive



EtherCAT/  
PROFINET  
380~480VAC  
0.28~14kW  
1500/2000r/min  
3000/4500r/min

**C/F/K/S-MX**  
&AX齿轮伺服马达&伺服驱动器  
Servo Gearmotor & Servo Drive

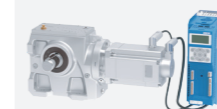
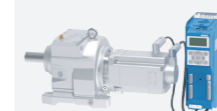
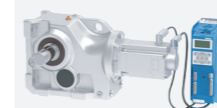

EtherCAT/  
PROFINET  
380~480VAC  
0.28~14kW  
i=1.25~315

**PX-MX&AX**  
行星伺服马达&伺服驱动器  
Planetary Precision Gear Servo Motor & Servo Drive

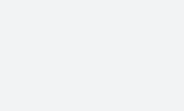

EtherCAT/  
PROFINET  
380~480VAC  
0.38~14kW  
i=3~100

**PN-MN&AN**  
行星伺服马达&伺服驱动器  
Planetary Precision Gear Servo Motor & Servo Drive



EtherCAT  
PROFINET  
380~480VAC  
0.28~5.03kW  
i=3~100

**ME&AN**  
永磁同步伺服马达&伺服驱动器  
Permanent Magnet Servo Motor & Servo Drive



EtherCAT/  
PROFINET  
200~240VAC  
0.1kW~1.2kW

<b>博能传动(沈阳)有限公司</b>	<b>BONENG TRANSMISSION(SHENYANG)CO.,LTD.</b>
辽宁省沈阳市沈北新区 太平洋工业城A区A73-6号 电话: 024-31271571	No. A73-6, Area A, Pacific Industrial City, Shenbei New District, Shenyang, Liaoning Province, China TEL: 024-31271571
<b>博能传动(天津)有限公司</b>	<b>BONENG TRANSMISSION(TIANJIN)CO.,LTD.</b>
天津市北辰区双海道6号 宏鹏工业园7号车间 电话: 022-26929556	7th Workshop, Hongpeng Industrial Park, No. 6 Shuanghai Road, Beichen District, Tianjin City,China TEL: 022-26929556
<b>博能传动(潍坊)有限公司</b>	<b>BONENG TRANSMISSION(WEIFANG)CO.,LTD.</b>
山东省潍坊市安丘市经济开发区 汶水路与昆仑大街交叉口往北 100米路东1号车间 电话: 0536-2141166	1st Workshop, Economic Development Zone, Anqiu, Weifang City, Shandong Province, China TEL: 0536-2141166
<b>博能传动(开封)有限公司</b>	<b>BONENG TRANSMISSION(KAIFENG)CO.,LTD.</b>
河南省开封市宋城路四大街11号 海神机械院内五号厂房 电话: 0371-23335238	5th Workshop, Haishen Machinery, No.11, Fourth Street, Songcheng Road,New District, Kaifeng City, Henan Province, China TEL: 0371-23335238
<b>博能传动(长沙)有限公司</b>	<b>BONENG TRANSMISSION(CHANGSHA)CO.,LTD.</b>
湖南省长沙市望城经济开发区 普瑞大道1288号 电话: 0731-88386958	No. 1288 Puri Avenue, Wangcheng Economic Development Zone, Changsha City, Hunan Province, China TEL: 0731-88386958
<b>博能传动设备(成都)有限公司</b>	<b>BONENG TRANSMISSION EQUIPMENT(CHENGDU) CO., LTD.</b>
四川省成都市金牛区金牛坝路9号5栋 向荣中心A座7楼-703 电话: 028-87741100	703, 7th Floor, Block A, Xiangrong Center, Building 5, No. 9 Jinniuba Road, Jinniu District, Chengdu City, Sichuan Province, China TEL: 028-87741100
<b>博能传动(肇庆)有限公司</b>	<b>BONENG TRANSMISSION(ZHAOQING)CO.,LTD.</b>
广东省肇庆市鼎湖区肇庆新区 科创大道7号平谦国际现代产业园 一期A12北厂房 电话: 0757-86719757	No. 7 Science and Technology Innovation Avenue, Zhaoqing New Area, Dinghu District, Zhaoqing City, Guangdong Province, China TEL: 0757-86719757
<b>博能传动(苏州)有限公司</b>	<b>BONENG TRANSMISSION(SUZHOU)CO.,LTD.</b>
江苏省苏州市相城区如元路100号 电话: 0512-66189662	No. 100, Ruyuan Road, Xiangcheng District, Suzhou, Jiangsu Province, China TEL: 0512-66189662

<b>博能传动(美国)有限公司</b>	<b>BONENG TRANSMISSION(USA)LLC.</b>
1250 E 222nd Euclid, OH 44117, United Staes TEL: 1-216-618-0138 TEL: 1-216-618-0496 TEL: 1-216-618-3099	1250 E 222nd Euclid, OH 44117, United Staes TEL: 1-216-618-0138 TEL: 1-216-618-0496 TEL: 1-216-618-3099
<b>博能传动(印度)有限公司</b>	<b>BONENG TRANSMISSION(INDIA)PVT.LTD</b>
Plot No. E-10/3, MIDC sinnar (Malegaon) Industrial Area, Nashik, 422123, Maharashtra, India. TEL:+91-11- 4507 6293 (DELHI) TEL:+91-22-2781 3385 (MUMBAI)	Plot No. E-10/3, MIDC sinnar (Malegaon) Industrial Area, Nashik, 422123, Maharashtra, India. TEL:+91-11- 4507 6293 (DELHI) TEL:+91-22-2781 3385 (MUMBAI)